

LX-300+II Parts

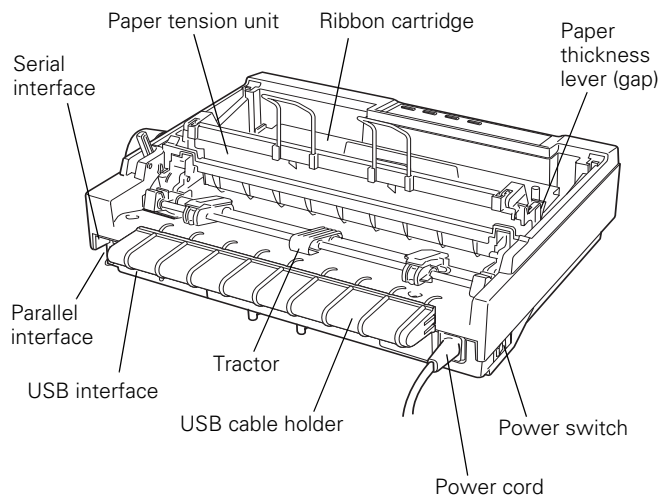
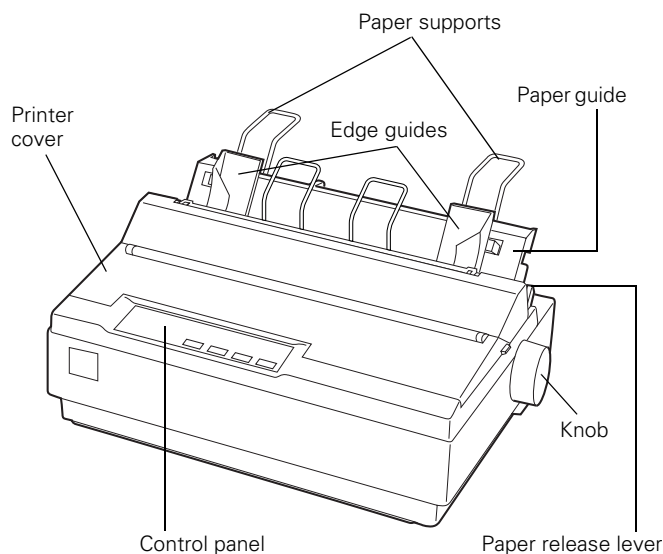

User Replaceable Parts

User replaceable part	Reference number	Part number
Knob	106	1051718
Logo plate	120	1056595
Paper supports	180	1054395
Paper eject assembly	570	1050616
Printer cover assembly	105	1050626
Sheet guide assembly	109	1050625

Options

You can purchase the following options from an Epson authorized reseller. To find the nearest reseller, call 800-GO-EPSON (800-463-7766). Or you can purchase online at www.epsonstore.com (U.S. sales) or www.epson.ca (Canada sales).

Single-bin Cut-sheet Feeder (C806371)

Feeds up to 50 sheets of ordinary single-sheet paper.

Additional Tractor Unit (C800301)

Used in combination with the other tractor, improves continuous paper handling and reduces the chance of paper jams. Two tractors are especially useful for printing on continuous multipart forms.

Roll Paper Holder (C12C811141 or 8310)

Allows you to use 8.5-inch roll paper in your printer.

Black Ribbon Cartridge (#8750)

Expected ribbon life is approximately 3 million characters.

Printer Specifications

Mechanical

Printing method	9-pin impact dot matrix	Paper feed methods	Friction (top paper entry) Push tractor (rear paper entry) Pull tractor (rear paper entry) Push and pull tractor (optional) Cut-sheet feeder (optional) Roll paper holder (optional)
Printing speed	High-speed draft 300 cps at 10 cpi 337 cps at 12 or 15 cpi High-speed draft condensed 321 cps at 17 cpi 300 cps at 20 cpi Draft 225 cps at 10 cpi 270 cps at 12 cpi 225 cps at 15 cpi Draft condensed 191 cps at 17 cpi 225 cps at 20 cpi Draft emphasized 112 cps at 10 cpi NLQ 56 cps at 10 cpi 67 cps at 12 cpi 56 cps at 15 cpi 47 cps at 17 cpi 56 cps at 20 cpi	Paper feed speed	Continuous 3 inches/second (76 mm/second) Intermittent 63ms/line at 1/6-inch line spacing
Printing direction	Bidirectional logic seeking for text and graphics printing. Unidirectional text or graphics printing can be selected using software commands.	Buffer	64KB
Line spacing	1/6 inch or programmable in 1/216-inch increments	Built-in fonts	<i>Bitmap fonts</i> Epson Draft 10, 12, 15 cpi Epson Roman 10, 12, 15 cpi, proportional Epson Sans Serif 10, 12, 15 cpi, proportional <i>Bar code fonts</i> EAN-13, EAN-8, Interleaved 2 of 5, UPC-A, UPC-E, Code 39, Code 128, POSTNET
Printable columns	80 columns (at 10 cpi)	Character tables	One Italic table and 12 graphical character tables (26 graphical character tables are available in some countries)
Resolution	240 × 144 dpi maximum	Character sets	13 international character sets
Emulation	Epson ESC/P® and IBM® 2380 Plus (see the <i>Reference Guide</i> for control codes)	Reliability	Total print volume 12 million lines (except print head) MTBF 6,000 POH (25% duty) Print head life approximately 400 million strokes per wire
Interfaces	One standard bidirectional, 8-bit parallel interface with IEEE-1284 nibble mode support, one EIA-232D serial interface, and one USB (ver 1.1) interface	Dimensions and weight	Height 6.3 inches (160 mm) Width 14.4 inches (366 mm) Depth 10.8 inches (275 mm) Weight 9.7 lb (4.4 kg)
		Ribbon	Black ribbon cartridge (#8750) Ribbon life: 3 million characters
		Acoustic noise	Approx. 49 dB (A) (ISO 7779 pattern)

Electrical

	120 V	220 to 240 V
Input voltage range	99 to 132 V	198 to 264 V
Rated frequency range	50 to 60 Hz	
Input frequency range	49.5 to 60.5 Hz	
Rated current	0.6 A (maximum 1.4 A depending on the character type)	0.3 A (maximum 0.7 A depending on the character type)
Power consumption	Approx. 23 W (ISO/IEC 10561 letter pattern) Energy Star Compliant	

Environmental

	Temperature (without condensation)	Humidity (without condensation)
Operation	41 to 95 °F (5 to 35 °C)	10 to 80% RH
Storage	-22 to 140 °F (-30 to 60 °C)	0 to 85% RH

Safety Approvals

	120 Volt	230 Volt
Safety standards	UL 60950 CSA 60950	EN 60950
EMI	FCC part 15 subpart B class B CAN/CSA CEI/IEC CISPR22, class B	AS/NZS CISPR22, class B

CE Marking (230 V model)

Low Voltage Directive 73/23/EEC	EN 60950
EMC Directive 89/336/EEC	EN 55022 Class B EN 61000-3-2 EN 61000-3-3 EN 55024

Paper

Use recycled paper, envelopes, and single-sheet multipart forms only under normal temperature and humidity conditions, as follows:

Temperature: 59 to 77 °F (15 to 25 °C)

Humidity: 30 to 60% RH

Do not load paper that has been folded or is damaged, wrinkled, or curled.

Ordinary single sheets: paper guide and cut-sheet feeder entry

Width	Paper guide
	3.9 to 10.1 inches (100 to 257 mm)
Cut-sheet feeder	7.2 to 8.5 inches (182 to 216 mm)
Length	Paper guide
	3.9 to 14.3 inches (100 to 364 mm)
Cut-sheet feeder	10.1 to 14 inches (257 to 356 mm)
Thickness	Paper guide: 0.0025 to 0.0055 inch (0.065 to 0.14 mm)
	Cut sheet feeder: 0.0028 to 0.0055 inch (0.07 to 0.14 mm)
Weight	Paper guide: 14 to 24 lb (52 to 90 g/m ²)
	Cut sheet feeder: 18 to 24 lb (64 to 90 g/m ²)

Single-sheet multipart forms: paper guide entry

Width	3.9 to 10.1 inches (100 to 257 mm)
Length	3.9 to 14.3 inches (100 to 364 mm)
Copies	1 original + up to 4 copies
Thickness	0.0047 to 0.015 inch (0.12 to 0.39 mm)
Weight	12 to 15 lb (40 to 58 g/m ²)
Binding	Line-glued at the top or one side of form

Envelopes: paper guide entry

Size	No. 6: 6.5 × 3.6 inches (165 × 92 mm)
	No. 10: 9.5 × 4.1 inches (241 × 105 mm)
Thickness	0.0063 to 0.0205 inch (0.16 to 0.52 mm)
Weight	12 to 24 lb (45 to 90 g/m ²)

Continuous paper (standard and multipart): rear and bottom entry

Width	4 to 10 inches (101.6 to 254 mm)
Length	4 to 22 inches (101.6 to 558.8 mm)
Copies	1 original + up to 4 copies
Thickness	Printable area
	0.0025 to 0.015 inch (0.065 to 0.39 mm)
	Perforated edges (gathering area) up to 0.035 inch (0.9 mm)

Weight (not multipart) 14 to 22 lb (52 to 82 g/m²)
 Weight (1 multipart sheet) 12 to 15 lb (40 to 58 g/m²)
 Binding Spot-glued or crimp-bound on both sides

**Continuous paper with labels:
 bottom entry only**

Label size 0.94 × 2.5 inches (23.8 × 63.5 mm) minimum;
 0.1 inch (2.5 mm) corner radius

Backing sheet

Width 4 to 10 inches (101.6 to 254 mm)
 Length 4 to 22 inches (101.6 to 558.8 mm)
 Thickness 0.0028 to 0.0035 inch (0.07 to 0.09 mm)

Total

thickness 0.0063 to 0.0075 inch (0.16 to 0.19 mm)

Label weight 17 lb (64 g/m²)

**Roll paper:
 rear entry with optional roll paper holder only**

Width 8.5 inches (216 mm)
 Thickness 0.0028 to 0.0035 inch (0.07 to 0.09 mm)
 Weight 14 to 22 lb (52 to 82 g/m²)

Paper Alignment

Printing starts at “0” on the scale. The unprintable area is to the left of the “0”.

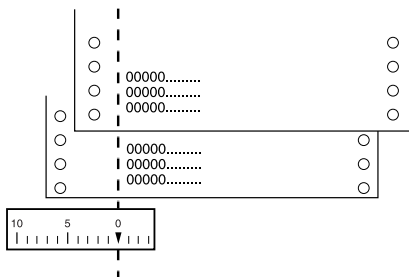

Printable Area

Single sheets and envelopes

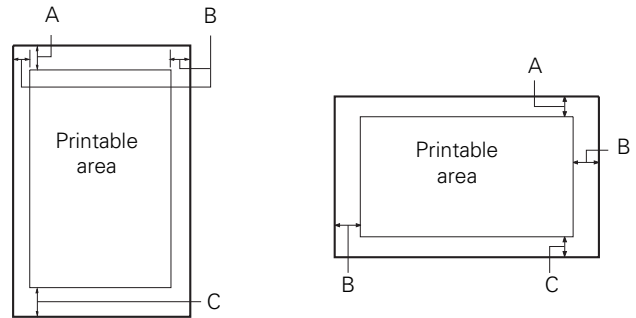

- A The minimum top margin is 0.17 inch (4.2 mm).
- B The minimum left and right margins are 0.12 inch (3 mm).
 The maximum paper width is 10.1 inches (257 mm).
 The maximum printable width is 8 inches (203.2 mm).
 If the paper size is substantially wider than this, the side margins will be wider than the minimum, but the printable width does not increase beyond 8.0 inches (203.2 mm).
- C The minimum bottom margin is 0.17 inch (4.2 mm).

Continuous paper

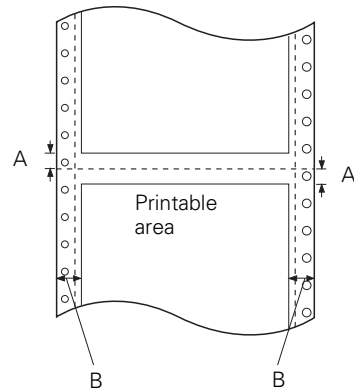

- A The minimum top and bottom margins above and below the perforation are 0.17 inch (4.2 mm).
- B The minimum left and right margins are 0.51 inch (13 mm).
 The maximum paper width is 10 inches (254 mm).
 The maximum printable width is 8 inches (203.2 mm).
 If the paper size is substantially wider than this, the side margins will be wider than the minimum, but the printable width does not increase beyond 8.0 inches (203.2 mm).

Roll paper

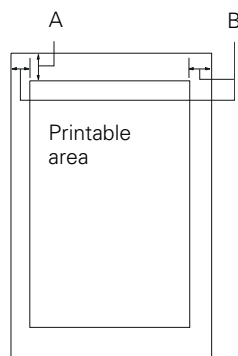

A The minimum top margin is 0.17 inch (4.2 mm).

B The minimum left and right margins are 0.12 inch (3 mm).
The maximum printable width is 8 inches (203.2 mm).

Control Panel Buttons and Lights

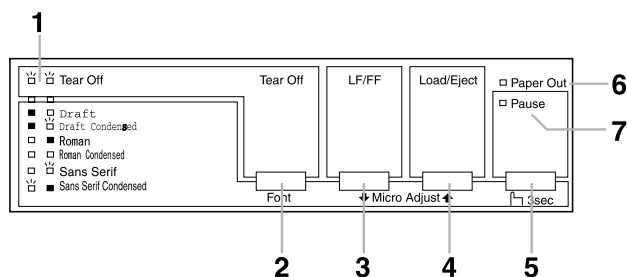

1 Tear Off (Font) lights

Flash when continuous paper is in the tear-off position; otherwise, the lights indicate the selected font.

2 Tear Off (Font) button

- Advances continuous paper to the tear-off position.
- Feeds continuous paper backward from the tear-off position to the top-of-form position.
- In Micro Adjust mode, selects one of the six built-in fonts.

3 LF/FF button

- Feeds paper line by line when pressed and released.
- Ejects a single sheet or advances continuous paper to the next top-of-form position when held down.
- In Micro Adjust mode, adjusts the top-of-form and tear-off position.

4 Load/Eject button

- Loads a single sheet of paper.
- Ejects a single sheet of paper.
- Loads continuous paper from the standby position.
- Feeds continuous paper backward to the standby position.
- In Micro Adjust mode, adjusts the top-of-form and tear-off positions.

5 Pause button

Stops printing temporarily, and resumes printing when pressed again. When held down for three seconds, turns on Micro Adjust mode. To turn it off, press it again.

6 Paper Out light

- On when no paper is loaded in the selected paper source or when paper is not loaded correctly.
- Flashes when paper has not been fully ejected or if paper is jammed in the printer.

7 Pause light

- On when the printer is paused.
- Flashes when the printer is in Micro Adjust mode.
- Flashes when the print head has overheated.

Selecting a Built-in Font

It is best to use your application program to select the font you want to use in a document. However, you may sometimes need to select one of the printer's six built-in fonts using the buttons on the control panel, as described below. (The settings you make in application programs usually override settings you make from the printer's control panel.)

- | | |
|-------------------------------------|---|
| <input type="checkbox"/> Draft | <input type="checkbox"/> Draft Condensed |
| <input type="checkbox"/> Roman | <input type="checkbox"/> Roman Condensed |
| <input type="checkbox"/> Sans Serif | <input type="checkbox"/> Sans Serif Condensed |

Follow these steps to use the control panel to select a built-in font:

1. Make sure that the printer is on but not printing.
2. Hold down the **Pause** button for three seconds to enter Micro Adjust mode. The Pause light begins to flash and the two Tear Off (Font) lights show the current font selection.
3. Press the **Tear Off (Font)** button repeatedly to cycle through the fonts, and stop when the lights on the control panel indicate the font you want. Your selection stays in effect until you change it again.

Error Indicators

You can identify many printer problems using the lights on the control panel. If your printer stops working and one or more control panel lights are on or flashing, or the printer beeps, use the following table to diagnose and fix the problem.

State of panel lights	Beep pattern	Problem Solution
□ Pause	—	The printer is paused. Press the Pause button to resume printing.
	••••	Paper from another paper source is currently in the paper path. Move the paper release lever to the correct position and press the Load/Eject button to feed the paper out of the paper path. Then set the lever to the position you want to use.
□ Paper Out □ Pause	•••	No paper is loaded in the selected paper source. Load paper in the printer. Then press the Pause button to turn off the Pause light, if necessary.
	•••	The paper is not loaded correctly. Remove your paper and reload it. Then press the Pause button to turn off the Pause light, if necessary.
	•••	Paper is jammed in the printer. Clear the paper jam.
⏏ Paper Out □ Pause	•••	Continuous paper is not fed to the standby position. Tear off the printed document at the perforation; then press the Load/Eject button. The printer feeds the paper to the standby position. Press the Pause button to turn off the Pause light.
	•••	A single sheet of paper is not fully ejected. Press the Load/Eject button to eject the sheet. Then press the Pause button to turn off the Pause light, if necessary.
	•••	Paper is jammed in the printer. Clear the paper jam.

State of panel lights	Beep pattern	Problem Solution
⏏ Pause	—	The print head is overheated. Wait a few minutes; the printer resumes printing automatically once the print head cools.
⏏ Paper Out ⏏ Pause ⏏ Tear Off	—	An unknown printer error has occurred. Turn off the printer and leave it off for several minutes; then turn on the printer again. If the error recurs, contact your dealer.

- = on, ⏏ = flashing
- = short series of beeps (three beeps)
- = long series of beeps (five beeps)

Note The printer beeps once if you press a control panel button when the corresponding function is not available.

Paper Positions

Top-of-Form Position

The top-of-form position is where the printer starts printing on the page.

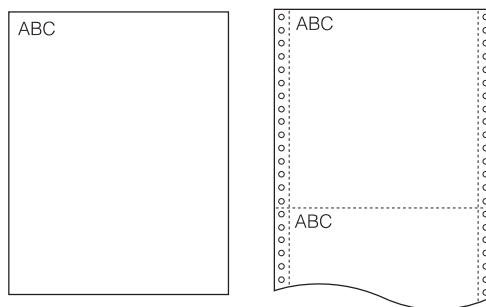

The letters ABC are printed at the top-of-form position

Tear-off Position

Continuous paper is in the tear-off position when the perforation is aligned with the tear-off edge. You can easily tear off your printed document at this position.

Standby Position

Continuous paper is in the standby position when it is attached to the tractor but not loaded in the printer.

Printing on Continuous Paper

You can print on continuous paper using the tractor in either the push or pull position:

- ❑ Use the tractor in the push position if you want to be able to switch between printing on single sheets and continuous paper without removing the paper supply, or if you will be tearing off continuous paper sheet-by-sheet. (Follow the instructions in the next section.) The printer comes with the tractor installed in the push position.
- ❑ Use the tractor in the pull position if you will be printing on labels, multipart forms, or other documents that require a precise print position. (See “Printing with the pull tractor” on page 9 for instructions.)

Printing with the push tractor

Follow these steps to load continuous paper on the push tractor:

1. Turn off the printer.
2. Remove the printer cover and the paper guide, and pull the paper release lever forward to the continuous paper position.

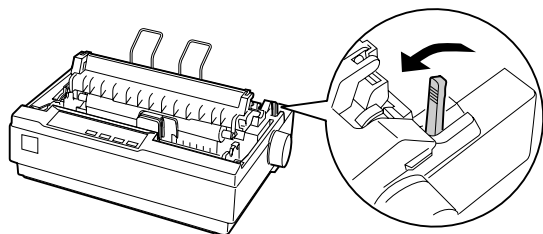

3. Unlock the sprockets on the tractor by pulling the blue lock levers forward.

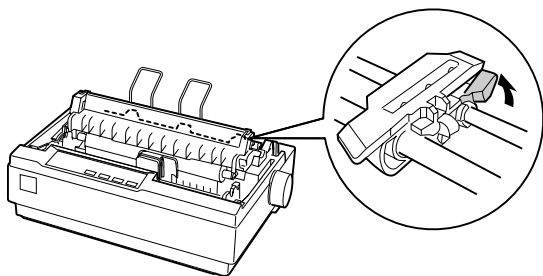

4. Slide the left sprocket so the pins are above the 0 mark on the printer scale (beneath the tractor). The printer starts printing to the right of this position.

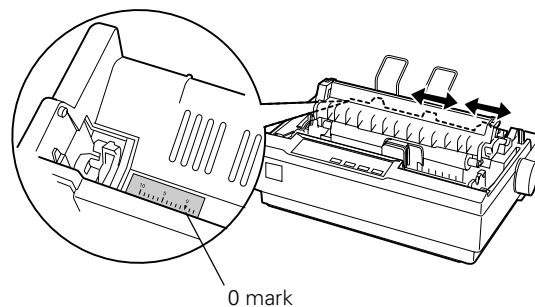

5. Push the lock lever back to lock it in place. Then slide the right sprocket to match the width of your paper, but do not lock it. Move the paper support so it is midway between the sprockets.
6. Stack your continuous paper behind the printer. Make sure there are no obstructions between the paper and the printer, and that the paper is aligned squarely with the printer so it will feed in straight.
7. Make sure your paper has a clean, straight, leading edge. Then open the sprocket covers and fit the first holes of the paper over the sprocket pins.

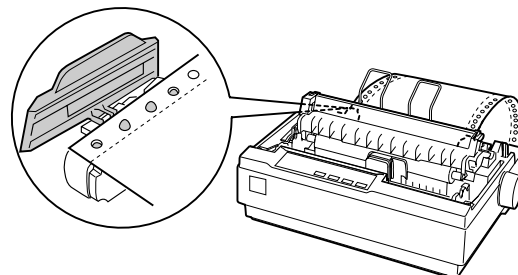

8. Close the covers. Slide the right sprocket to remove any slack in the paper and lock it in place.

- To separate the incoming paper from the printed paper, attach the paper guide by holding it horizontally and fitting its notches over the printer's mounting posts as shown below. Then slide the paper guide toward the front of the printer until you feel it click.

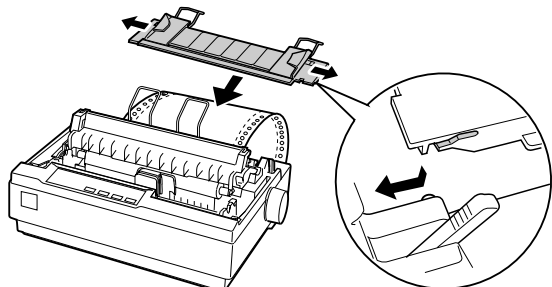

- Replace the printer cover and close it.
- Turn on the printer.
- When using the push tractor, it is a good idea to turn on the Auto tear off feature in Default Setting mode. See "Changing Default Settings" on page 14.
- Press the LF/FF button to feed the paper to the loading position. When the printer receives data, it begins printing automatically.
- After you finish printing, follow the steps in the next section to tear off your printed document. If the first printed line on your page appears too high or too low, you can change its position by using the Micro Adjust feature. See "Adjusting the top-of-form position" on page 10.



Never use the paper feed knob to adjust the top-of-form position; this may damage the printer or cause it to lose the top-of-form position.

The paper automatically feeds back to the loading position the next time you print.

Removing a printed document from the push tractor

Follow these steps to remove the printed document:

- Press the Tear Off (Font) button. The paper moves to the tear-off position and the Tear Off (Font) lights start flashing.

- Open the printer cover, then tear off the printed document using the tear-off edge on the paper tension unit.

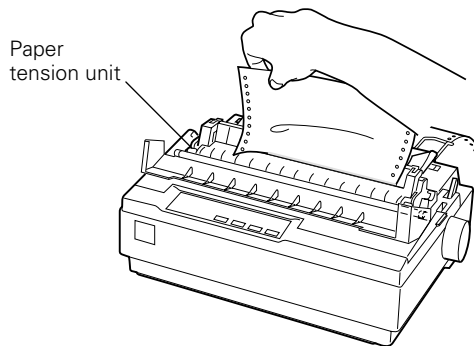

If your paper's perforation is not properly aligned with the tear-off edge, you can adjust the tear-off position using the Micro Adjust feature. See "Adjusting the tear-off position" on page 11.

- Close the printer cover.

When you resume printing, the printer automatically feeds the paper back to the top-of-form position and starts printing.

To feed continuous paper backward to the standby position, where you can remove the paper, first tear off any printed sheets. Then press the Load/Eject button. Open the sprocket covers on the tractor and remove the paper.



Always tear off your printed document before you press the Load/Eject button. Reverse feeding several pages at a time may cause a paper jam.

Switching between continuous paper and single sheets

If you want to switch to single sheets while continuous paper is loaded in the push tractor position, follow these steps:

- Tear off your printed document.



Always tear off your printed document before you press the Load/Eject button. Reverse feeding several pages at a time may cause a paper jam.

- Press the Load/Eject button to feed the paper backward to the standby position.
- Push the paper release lever back to the single sheet position.
- Follow the instructions on page 12 to load single sheets.

To switch back to continuous paper, follow these steps:

1. Press the **Load/Eject** button to eject any sheet in the printer.
2. Move the paper release lever to the continuous paper position.
3. Press the **LF/FF** button to load the paper on the tractor.

Printing with the pull tractor

To load continuous paper using the pull tractor, you must move the tractor to the pull tractor position, as described below. If your tractor is already installed in this position, make sure the printer is turned off and skip to step 6.

1. Turn off the printer; then remove the printer cover and the paper guide.
2. Remove the paper tension unit by gently squeezing the lock tabs and pulling it out of the printer.

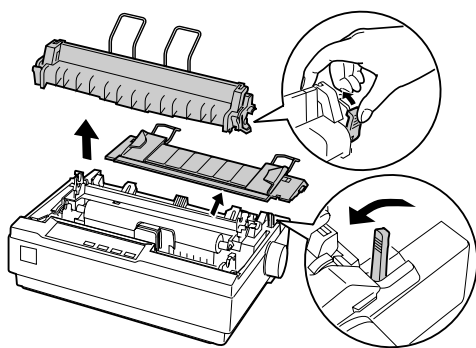

3. Pull the paper release lever forward to the continuous paper position.
4. To remove the tractor from the push position, gently squeeze the lock tabs on both sides and then rotate the tractor up to pull it away from the printer.

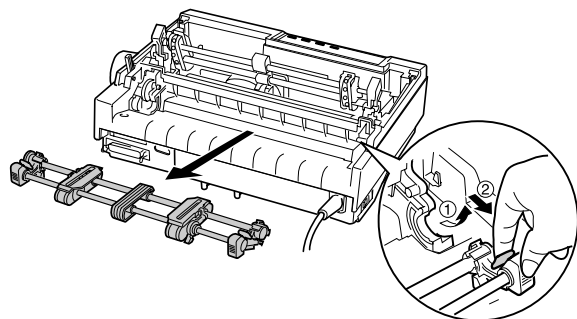

5. Lower the tractor onto the mounting slots at the top of the printer as shown below, and tilt it back until you feel it lock into place.

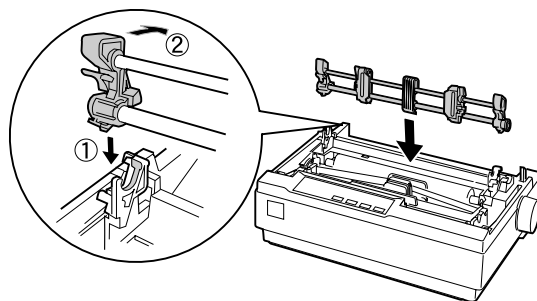

6. Unlock the sprockets by pulling the blue lock levers forward.

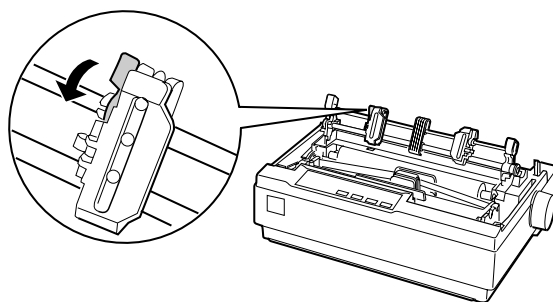

7. Feed the paper into the rear paper slot as shown below, and pull it up. Position the paper using the scale on the printer as a guide. Printing starts to the right of the position marked **0** (under the paper now).

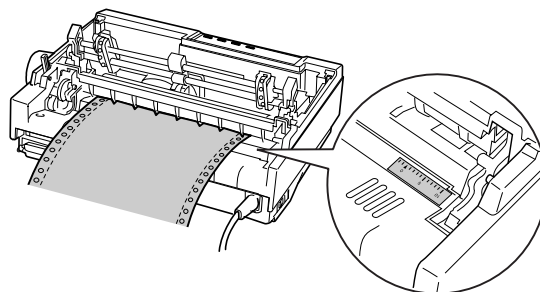

- Slide the left sprocket so its pins are aligned with the holes in the paper and push the blue lock lever to lock the sprocket in place. Then slide the right sprocket to match the width of your paper, but do not lock it. Move the paper supports midway between the two sprockets.

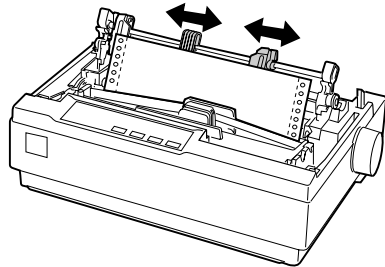

- Make sure your paper has a clean, straight leading edge. Open the sprocket covers. Fit the first holes of the paper over the sprocket pins and then close the sprocket covers. Slide the right sprocket to remove any slack in the paper and then lock it in place.

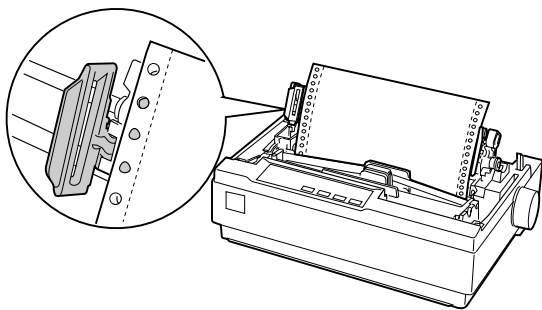

Note Remove any remaining slack by gently pulling the paper from the back.

- To separate the incoming paper from the printed paper, attach the paper guide. Hold it horizontally and fit its notches over the printer's mounting posts. Then slide the paper guide toward the back of the printer until you feel it click.
- Turn the paper feed knob to adjust the paper position. The perforation between pages should be just above the print head.
- Replace the printer cover but leave it open.
- Turn on the printer.
- Set the Auto tear off feature in the Default Setting mode to Off; otherwise, the paper may jam. (See page 14 for more information.)

When the printer receives data, it begins printing automatically. If you want to change the position where printing begins on the page, press the LF/FF button to advance the page to the next top-of-form position, and then see the next section to adjust the loading position.

To eject the paper, tear off the paper entering the printer; then press the LF/FF button to feed the paper forward.

Adjusting the top-of-form position

If your printing appears too high or too low on the page, you can use the Micro Adjust feature to adjust the top-of-form position.



Never use the paper feed knob to adjust the top-of-form position; this may damage the printer or cause it to lose the top-of-form position.

- Make sure the printer is turned on and paper is loaded.
- Remove the printer cover.
- Hold down the **Pause** button for about three seconds. The printer beeps and the Pause light starts flashing as the printer enters Micro Adjust mode.
- Press the **LF/FF** \downarrow button to move the top-of-form position higher on the page, or press the **Load/Eject** \uparrow button to move the top-of-form position lower on the page.

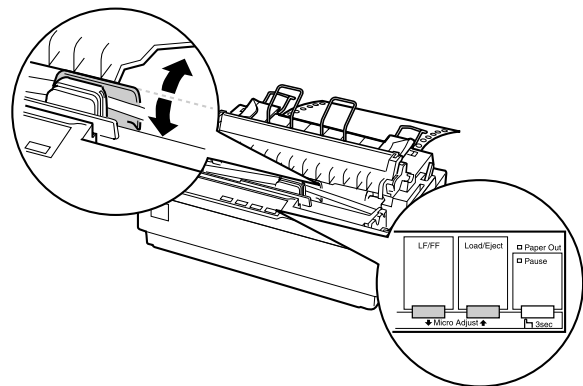

The printer has a minimum and a maximum top-of-form position. If you try to adjust it beyond these limits, the printer beeps and stops moving the paper.

When the paper reaches the default top-of-form position, the printer beeps and stops moving the paper briefly. You can use the default position as a reference point when adjusting the top-of-form position.

- After you set the top-of-form position, press the **Pause** button to exit the Micro Adjust mode.

Your top-of-form position setting remains in effect until you change it, even if you turn off the printer.

Note The top margin setting made in some software applications overrides the top-of-form position setting you make with the Micro Adjust feature. If necessary, adjust the top-of-form position in your software.

If you want to restore the printer's default top-of-form position, you can reset the printer. See "Restoring the printer's default settings" on page 14 for instructions.

Advancing paper to the tear-off edge

When the push tractor is installed, you can use the tear-off feature to advance your continuous paper to the printer's tear-off edge when you finish printing. You can then easily tear off the printed document. When you resume printing, the printer automatically feeds the paper back to the top-of-form position; so you can save the paper normally lost between documents.

You can use the tear-off feature in two ways:

- ❑ Manually, by pressing the printer's Tear Off (Font) button
- ❑ Automatically, by turning on the Auto tear off function in Default Setting mode.

Using the Tear Off button

After the printer finishes printing your document, check that the Tear Off (Font) lights are not flashing. Then press the Tear Off (Font) button. The printer advances the paper to the tear-off edge.

Note If the Tear Off (Font) lights are flashing, the paper is in the tear-off position. If you press the Tear Off (Font) button again, the printer feeds your paper to the next top-of-form position.

Advancing paper to the tear-off position automatically

To automatically advance your printed documents to the tear-off position, you need to turn on the Auto tear off mode and select the appropriate page length for continuous paper in Default Setting mode. For instructions, see "Default Settings" on page 14.

When Auto tear off is on, the printer automatically advances the paper to the tear-off position whenever it receives a full page of data or a form feed command followed by no more data.

Adjusting the tear-off position

If your paper's perforation is not aligned with the tear-off edge, you can use the Micro Adjust feature to move the perforation to the tear-off position.

Follow these steps to adjust the tear-off position:

1. Make sure the Tear Off (Font) lights are flashing (the paper is at the current tear-off position). You may need to press the Tear Off (Font) button to advance the paper to the tear-off position.
2. Open the printer cover.
3. Hold down the Pause button for about three seconds. The printer beeps and the Pause light begins to flash as the printer enters Micro Adjust mode.
4. Press the LF/FF \downarrow button to feed the paper backward, or press the Load/Eject \uparrow button to feed the paper forward, until the paper perforation is aligned with the tear-off edge on the paper tension unit.

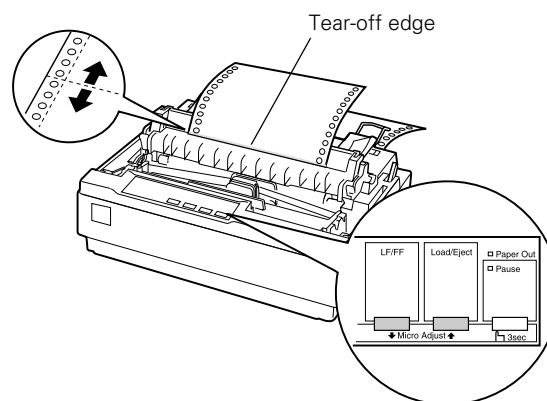

Note The printer has a minimum and a maximum tear-off position. If you try to adjust the tear-off position beyond these limits, the printer beeps and stops moving the paper.

5. After you set the tear-off position, press the Pause button to exit Micro Adjust mode.
6. Tear off the printed pages.

When you resume printing, the printer automatically feeds the paper back to the top-of-form position and begins printing.

Note Your tear-off position setting remains in effect until you change it, even if you turn off the printer. (If you want to restore the printer's default tear-off position, you can reset the printer. See page 14 for instructions.)

Printing on Single Sheets

You can load single sheets of paper one at a time using the printer's paper guide.

Before printing on single-sheet multipart forms, envelopes, or other special paper, make sure the paper thickness lever is set to the appropriate position. See "Printing on Special Paper" below.

Note Load only one sheet at a time. To load a stack of single-sheet paper, use the optional cut-sheet feeder. See the *Reference Guide* for more information.

You can use the paper guide to load single-sheet carbonless multipart forms that are fastened at the top by line gluing.

Insert multipart forms in the paper guide, bound edge first and printable side down.

Follow these steps to load a single sheet:

1. If continuous paper is loaded in the push tractor, press the Load/Eject button to feed it back to the standby position.
2. Push the paper release lever back to the single-sheet position and make sure the paper guide is in the upright position, as shown below.

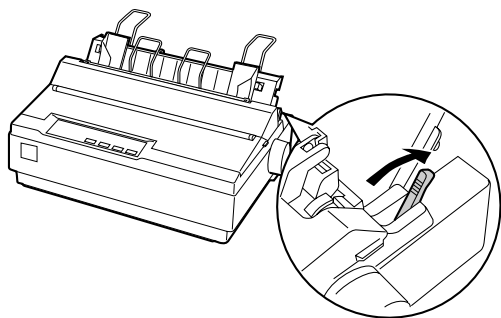

3. Slide the left edge guide until it locks in place at the guide mark. Then adjust the right edge guide to match the width of your paper.

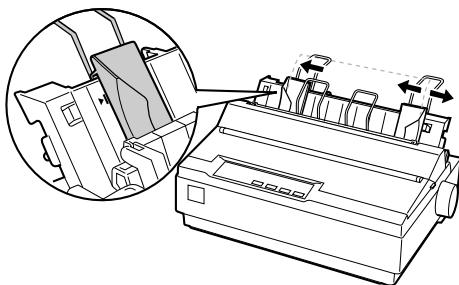

4. Insert a sheet of paper between the edge guides until it meets resistance. The printer automatically pulls it into the correct printing position.

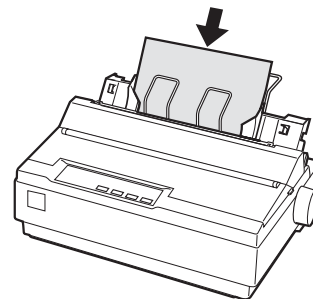

When the printer receives data, it begins printing. If the document is more than one page, the printer beeps three times after printing each page. Load the next sheet and the printer will continue printing.

Printing on Special Paper

You can print on a wide variety of special paper types, including multipart forms, labels, and envelopes.



When printing on multipart forms, thicker-than-normal paper, labels, or envelopes, make sure your application software settings keep the printing entirely within the printable area. Printing past the edge of these papers can damage the print head.

Adjusting the paper thickness lever

Before printing on special paper, you need to make sure the paper thickness lever is set correctly for the type of paper you're using. Follow these steps:

1. Turn off the printer.
2. Lift up or remove the printer cover. The paper thickness lever is on the left side of the printer.

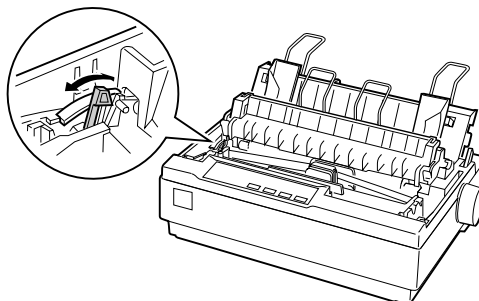

3. The numbers next to the lever indicate the thickness setting. Use the table below to select the appropriate paper thickness.

Paper type	Lever position
Standard paper (single sheets or continuous)	0
Multipart forms	0
2-sheet	1
3-sheet	2
4-sheet	3
5-sheet	
Labels	1
Envelopes	2 or 4

4. Close the printer cover.
5. Turn on the printer.

Multipart forms

You can use continuous or single-sheet carbonless multipart forms of up to five parts (one original plus four copies). Follow these guidelines:

- ❑ Set the paper thickness lever to the correct position for your forms as described above.
- ❑ Use continuous multipart forms that are joined only by spot gluing or side-crimping. Never load continuous multipart forms joined by metal staples, tape, or continuous gluing.
- ❑ Use single-sheet multipart forms that are line-glued only at the top. Insert the forms glued-edge-first into the printer.
- ❑ Make sure that multipart forms are not wrinkled.
- ❑ If you need to adjust the loading position, use your application software or change the top-of-form position as described on page 10.
- ❑ When you use side-crimped continuous multipart forms, the copies may not align with the original. If this happens, raise the paper guide.

For multipart forms, you should not print any closer than 0.5 inch (13 mm) from either side of the paper.

Labels

To print on labels, you must use continuous paper loaded on the pull tractor. Keep the following tips in mind:

- ❑ Set the paper thickness lever to the correct position for labels, as described above.
- ❑ Choose labels mounted on a continuous backing sheet with sprocket holes designed for tractor use. Do not print labels as single sheets, because the shiny backing causes the paper to slip slightly.
- ❑ Load labels the same way you load ordinary continuous paper. See page 9 for loading instructions.
- ❑ Because labels are especially sensitive to temperature and humidity, use them only under normal operating conditions.
- ❑ Do not leave labels loaded in the printer between jobs; they curl around the platen and may jam when you resume printing.
- ❑ To remove the labels from the printer, tear off the fresh supply at the back of the printer; then press the LF/FF button to advance the remaining labels out of the printer.



Never feed labels backward through the printer; they can easily peel off the backing sheet and jam the printer.

Envelopes

You can feed envelopes individually using the paper guide the same way you load single sheets. (See page 12.) Keep the following tips in mind:

- ❑ Set the paper thickness lever to the proper position. See page 12.
- ❑ Insert the envelope printable-side down, wide-edge-first, between the edge guides. Push it firmly and hold it until it feeds into the printer.
- ❑ Use envelopes only under normal temperature and humidity conditions.
- ❑ Make sure the printing stays entirely within the printable area.
- ❑ The print head must not go past the left or right edge of the envelope or other thick paper. It's a good idea to print a test sample using a normal single sheet of paper before you print on envelopes.

Default Settings

While you can often set the default settings through your application software or printer driver, you may need to change a default setting from the printer's control panel using Default setting mode. The table below lists the default settings (in bold) and options you can select in this mode. (For more information, see the *Reference Guide*.)

Settings	Options
Page length for tractor	Length in inches: 3, 3.5, 4, 5.5, 6, 7, 8, 8.5, 11 , 70/6, 12, 14, 17
Skip over perforation	On, Off
Auto tear-off	On, Off
Auto line feed	On, Off
Print direction	Bi-D , Uni-D
Software	ESC/P , IBM 2380 Plus
0 slash	On, Off
High speed draft	On , Off
I/F (interface) mode	Auto , Parallel, Serial
Auto I/F wait time	10 seconds , 30 seconds
Baud rate (bps)	19200 , 9600, 4800, 2400, 1200, 600, 300
Parity	None , Odd, Even, Ignore
Data length	7 bit, 8 bit
Parallel I/F bidirectional mode	On , Off
Packet mode	Auto , Off
Character table*	Standard model: Italic, PC 437 , PC 850, PC 860, PC 863, PC 865, PC 861, BRASCII, Abicomp, Roman 8, ISO Latin 1, PC 858, ISO 8859-15 All other models: Italic, PC 437, PC 850, PC 437 Greek, PC 853, PC 855, PC 852, PC 857, PC 866, PC 869, MAZOWIA, Code MJK, ISO 8859-7, ISO Latin 1T, Bulgaria, PC 774, Estonia, ISO 8859-2, PC 866 LAT, PC 866 UKR, PC APTEC, PC 708, PC 720, PC AR864, PC 860, PC 863, PC 865, PC 861, BRASCII, Abicomp, Roman 8, ISO Latin 1, PC 858, ISO 8859-15, PC 771, PC437 Slovenia, PC MC, PC1250, PC1251
International character set for Italic table	Italic U.S.A. , Italic France, Italic Germany, Italic U.K., Italic Denmark1, Italic Sweden, Italic Italy, Italic Spain1
Manual feed wait time	1 second, 1.5 seconds , 2 seconds, 3 seconds
Buzzer	On , Off
Auto CR (IBM 2380 Plus)*	On, Off
IBM character table*	Table 1, Table 2

* These settings take effect only when IBM 2380 Plus emulation is selected.

Changing Default Settings

Follow the steps below to enter Default Setting mode. If you use single sheets, you'll need to load a new sheet of paper each time the printer ejects a printed page.

1. Make sure paper is loaded and the printer is off.
2. Hold down the Tear Off (Font) button and then turn on the printer.

The printer enters Default Setting mode and prints instructions for selecting the language. The current language is indicated by which control panel lights are on. (For English, only the Pause light is on.)

3. If you want a different language, press the LF/FF button until the lights show the language you want.
4. Press the Tear Off (Font) button to print a list of all the current settings.
5. If the settings are all correct, turn off the printer to exit Default Setting mode.
If you want to change any settings, go to step 6.
6. Press the Tear Off (Font) button. The printer prints instructions for changing the settings.
7. Press the LF/FF button to scroll through the options for the selected setting until you see the one you want. Then press the Tear Off (Font) button to select the next setting you want to change.
8. When you finish making settings, turn off the printer to exit Default Setting mode.

Your new settings remain in effect until you change them again or reset the printer's defaults.

Restoring the printer's default settings

If you want to restore all the factory default settings, turn off the printer. Then hold down the Load/Eject, LF/FF, and Pause buttons while you turn on the printer.

Clearing a Paper Jam

If paper becomes jammed in the printer, follow these steps to remove it:

1. Turn off the printer, open (or remove) the printer cover, and remove the paper guide.
2. If continuous paper is jammed in the printer, tear off the fresh supply at the perforation nearest the paper entry slot.
3. Gently remove any paper inside the printer, including any torn pieces. You can use the knob on the right side of the printer to help feed the paper out.



Use the paper feed knob to clear paper jams only when the printer is off. Otherwise, you may damage the printer or change the top-of-form or tear-off position.

4. Replace the printer cover and paper guide, and turn on the printer. Make sure the Paper Out light is not flashing and the Pause light is off.

Bidirectional Alignment

If you notice that the vertical lines in your printout are not properly aligned, you can use the printer's bidirectional adjustment mode to correct this problem.



To complete the steps below, you need 5 letter or A-4 size single sheets or 5 pages of continuous paper. If you use single sheets, you need to load a new sheet of paper each time the printer ejects a printed sheet onto the paper guide.

1. Make sure paper is loaded and the printer is turned off.



Whenever you turn off the printer, wait at least 5 seconds before turning it back on; otherwise you may damage the printer.

2. While holding down the **Pause** button, turn on the printer. It enters the bidirectional adjustment mode, then prints instructions and the first set of alignment patterns.
3. As described in the instructions, compare the alignment patterns and select the pattern with the best alignment.
4. Follow the instructions to print the remaining sets of alignment patterns and select the pattern with the best alignment in each set.
5. After you select the best pattern in the final set of alignment patterns, turn off the printer and exit the bidirectional adjustment mode. Your selections are saved automatically.

Printing a Self Test

If you are having printing problems, you can run the printer's self test to help you determine whether the printer or the computer is causing the problem. If the self test results are satisfactory, the printer is working properly and the problem may be caused by your printer driver settings, application settings, computer, or interface cable. (Be sure to use a shielded interface cable.)

If the self test does not print properly, there is a problem with the printer. See the *Reference Guide* for possible solutions to the problem.

You can print the self test using either single sheets or continuous paper. Use paper that is at least 8.25 inches (210 mm) wide.

1. Make sure paper is loaded and the printer is turned off.
2. To run the test using a draft font, turn on the printer while holding down the **LF/FF** button. To run the test using the printer's near letter-quality font, hold down the **Load/Eject** button while you turn on the printer. (Either self test can help you determine the source of your printing problem, but the draft self test prints faster.)

After a few seconds, the printer begins printing the self test (a series of characters).



To temporarily stop the self test, press the **Pause** button. To resume, press it again.

3. To end the self test, press the **Pause** button to stop printing. If paper remains in the printer, press the **LF/FF** button to eject the printed page. Then turn off the printer.



Do not turn off the printer while it is printing the self test. Always press the **Pause** button to stop printing and the **LF/FF** button to eject the printed page before you turn off the printer.

Cleaning the Printer

To keep your printer operating at its best, you should clean it thoroughly several times a year. Follow these steps:

1. Remove any paper loaded in the printer and turn it off.
2. Unplug the power cord from the electrical outlet; then disconnect the interface cable from the printer.
3. Remove the paper guide. If a pull tractor or an optional cut-sheet feeder is installed, remove it.
4. Use a soft brush to carefully brush away all dust and dirt from the outer case and paper guide.

5. If the outer case or paper guide is still dirty, clean it with a soft, clean cloth dampened with mild detergent dissolved in water. Keep the printer cover in place and flat on top of the printer to prevent water from getting inside the printer.



Never use alcohols or thinners to clean the printer; these chemicals can damage the printer components as well as the case.

Be careful not to get water on the printer mechanism or electronic components.

Do not use a hard or abrasive brush.

Do not spray lubricants inside the printer; unsuitable lubricants can damage the printer mechanism.

Related Documentation

Manual	Part number
Epson LX-300+II User's Guide	4105348-00/CPD-21412
CD-ROM containing the on-screen Reference Guide	3101470-00/CPD-21416

Transporting the Printer

If you need to transport your printer for some distance, carefully repack it using the original box and packing materials or equivalent packaging.



When transporting the printer, do not lift it by the USB cable holder as the holder may detach and cause the printer to fall. Hold the bottom left and right sides of the printer firmly to lift it.



You need to move the print head by hand to remove the ribbon cartridge. If you have just used the printer, the print head may be hot; let it cool for a few minutes before touching it.

1. Remove any paper loaded in the printer. Make sure the printer is turned off.
2. Unplug the power cord from the electrical outlet; then disconnect the interface cable from the printer.
3. Remove the paper guide, the USB cable holder, paper supports, and knob.
4. Make sure the tractor that comes with your printer is installed in the push position.
5. If an additional pull tractor is installed, remove it. If any options are installed, remove them and pack them in their original boxes.
6. Make sure the print head is not hot. Then remove the ribbon cartridge.
7. Repack the printer, ribbon cartridge, and paper guide in the original packing materials and place them in the printer's original box.