

# SERVICE MANUAL



Color Inkjet Printer

**EPSON Stylus Photo R300/R310**

**EPSON**

SEIJ03009

# Notice

- ❑ All rights reserved. No part of this manual may be reproduced, stored in a retrieval system, or transmitted in any form or by any means electronic, mechanical, photocopying, or otherwise, without the prior written permission of SEIKO EPSON CORPORATION.
- ❑ The contents of this manual are subject to change without notice.
- ❑ All effort have been made to ensure the accuracy of the contents of this manual. However, should any errors be detected, SEIKO EPSON would greatly appreciate being informed of them.
- ❑ The above notwithstanding SEIKO EPSON CORPORATION can assume no responsibility for any errors in this manual or the consequences thereof.

EPSON is a registered trademark of SEIKO EPSON CORPORATION.

*General Notice: Other product names used herein are for identification purpose only and may be trademarks or registered trademarks of their respective owners.  
EPSON disclaims any and all rights in those marks.*

Copyright © 2003 **SEIKO EPSON CORPORATION.**  
**Imaging & Information Product Division**  
**TP • CS Quality Assurance Department**

# PRECAUTIONS

Precautionary notations throughout the text are categorized relative to 1) Personal injury and 2) damage to equipment.

***DANGER*** Signals a precaution which, if ignored, could result in serious or fatal personal injury. Great caution should be exercised in performing procedures preceded by DANGER Headings.

***WARNING*** Signals a precaution which, if ignored, could result in damage to equipment.

The precautionary measures itemized below should always be observed when performing repair/maintenance procedures.

## **DANGER**

1. ALWAYS DISCONNECT THE PRODUCT FROM THE POWER SOURCE AND PERIPHERAL DEVICES PERFORMING ANY MAINTENANCE OR REPAIR PROCEDURES.
2. NO WORK SHOULD BE PERFORMED ON THE UNIT BY PERSONS UNFAMILIAR WITH BASIC SAFETY MEASURES AS DICTATED FOR ALL ELECTRONICS TECHNICIANS IN THEIR LINE OF WORK.
3. WHEN PERFORMING TESTING AS DICTATED WITHIN THIS MANUAL, DO NOT CONNECT THE UNIT TO A POWER SOURCE UNTIL INSTRUCTED TO DO SO. WHEN THE POWER SUPPLY CABLE MUST BE CONNECTED, USE EXTREME CAUTION IN WORKING ON POWER SUPPLY AND OTHER ELECTRONIC COMPONENTS.
4. WHEN DISASSEMBLING OR ASSEMBLING A PRODUCT, MAKE SURE TO WEAR GLOVES TO AVOID INJURIER FROM METAL PARTS WITH SHARP EDGES.

## **WARNING**

1. REPAIRS ON EPSON PRODUCT SHOULD BE PERFORMED ONLY BY AN EPSON CERTIFIED REPAIR TECHNICIAN.
2. MAKE CERTAIN THAT THE SOURCE VOLTAGES IS THE SAME AS THE RATED VOLTAGE, LISTED ON THE SERIAL NUMBER/RATING PLATE. IF THE EPSON PRODUCT HAS A PRIMARY AC RATING DIFFERENT FROM AVAILABLE POWER SOURCE, DO NOT CONNECT IT TO THE POWER SOURCE.
3. ALWAYS VERIFY THAT THE EPSON PRODUCT HAS BEEN DISCONNECTED FROM THE POWER SOURCE BEFORE REMOVING OR REPLACING PRINTED CIRCUIT BOARDS AND/OR INDIVIDUAL CHIPS.
4. IN ORDER TO PROTECT SENSITIVE MICROPROCESSORS AND CIRCUITRY, USE STATIC DISCHARGE EQUIPMENT, SUCH AS ANTI-STATIC WRIST STRAPS, WHEN ACCESSING INTERNAL COMPONENTS.
5. DO NOT REPLACE IMPERFECTLY FUNCTIONING COMPONENTS WITH COMPONENTS WHICH ARE NOT MANUFACTURED BY EPSON. IF SECOND SOURCE IC OR OTHER COMPONENTS WHICH HAVE NOT BEEN APPROVED ARE USED, THEY COULD CAUSE DAMAGE TO THE EPSON PRODUCT, OR COULD VOID THE WARRANTY OFFERED BY EPSON.

# About This Manual

This manual describes basic functions, theory of electrical and mechanical operations, maintenance and repair procedures of the printer. The instructions and procedures included herein are intended for the experienced repair technicians, and attention should be given to the precautions on the preceding page.

## Manual Configuration

This manual consists of six chapters and Appendix.

### **CHAPTER 1. TROUBLESHOOTING**

Describes the step-by-step procedures for the troubleshooting.

### **CHAPTER 2. DISASSEMBLY / ASSEMBLY**

Describes the step-by-step procedures for disassembling and assembling the product.

### **CHAPTER 3. ADJUSTMENT**

Provides Epson-approved methods for adjustment.

### **CHAPTER 4. MAINTENANCE**

Provides preventive maintenance procedures and the lists of Epson-approved lubricants and adhesives required for servicing the product.

### **APPENDIX Provides the following additional information for reference:**

- Electrical circuit boards schematics

## Symbols Used in this Manual

Various symbols are used throughout this manual either to provide additional information on a specific topic or to warn of possible danger present during a procedure or an action. Be aware of all symbols when they are used, and always read NOTE, CAUTION, or WARNING messages.



Indicates an operating or maintenance procedure, practice or condition that is necessary to keep the product's quality.



Indicates an operating or maintenance procedure, practice, or condition that, if not strictly observed, could result in damage to, or destruction of, equipment.



May indicate an operating or maintenance procedure, practice or condition that is necessary to accomplish a task efficiently. It may also provide additional information that is related to a specific subject, or comment on the results achieved through a previous action.



Indicates an operating or maintenance procedure, practice or condition that, if not strictly observed, could result in injury or loss of life.



Indicates that a particular task must be carried out according to a certain standard after disassembly and before re-assembly, otherwise the quality of the components in question may be adversely affected.

# Revision Status

Revision	Issued Date	Description
A	October 30, 2003	First Release

# CONTENTS

## Chapter 1 TROUBLESHOOTING

---

1.1 Overview .....	8
1.2 Troubleshooting with LED/LCD Indications and Status Monitor 3 Message .....	9
1.3 Unit Level Troubleshooting .....	14

## Chapter 2 DISASSEMBLY AND ASSEMBLY

---

2.1 Overview .....	32
2.1.1 Precautions .....	32
2.1.2 Tools .....	33
2.1.3 Pre-Shipment Checks .....	33
2.2 Caution regarding assembling/disassembling the printer mechanism, and how to ensure the quality of reassembled product .....	35
2.3 Disassembly .....	37
2.3.1 Removing Paper Support Assy. ....	38
2.3.2 Removing Housing, Upper .....	39
2.3.3 Removing Housing, Middle .....	41
2.3.4 Removing Porous Pad, Paper Guide, Front .....	43
2.3.5 Removing Panel Board .....	44
2.3.6 Removing Stacker Assy. ....	45
2.3.7 Removing Main Board .....	46
2.3.8 Removing ASF Assy. ....	49
2.3.9 Removing Holder, Shaft Assy. ....	51
2.3.10 Removing CR Motor .....	54
2.3.11 Removing APG Assy. ....	55
2.3.12 Removing Print Head .....	56
2.3.13 Removing Carriage Unit .....	57
2.3.14 Removing Paper Guide, Upper .....	63
2.3.15 Removing Printer Mechanism/Housing, Lower .....	64
2.3.16 Removing Power Supply Unit .....	68
2.3.17 Removing CDR Guide Assy. ....	69
2.3.18 Removing Ink System .....	71

2.3.19 Removing Paper Guide, Front/Roller EJ Assy. ....	74
2.3.20 Removing PF Motor .....	78

## Chapter 3 ADJUSTMENT

---

3.1 Adjustment Items and Overview .....	80
3.1.1 Servicing Adjustment Item List .....	80
3.1.2 Replacement Part-Based Adjustment Priorities .....	83
3.2 Adjustment by using adjustment program .....	85
3.2.1 Market Setting .....	85
3.2.2 USB ID Input .....	85
3.2.3 Head ID Input .....	85
3.2.4 Head Angular Adjustment .....	86
3.2.5 Bi-d Adjustment .....	86
3.2.6 PW Sensor Adjustment .....	87
3.2.7 First Dot Adjustment .....	87
3.2.8 Offset Input for CR Motor Calorific Limitation .....	88
3.2.9 A4 Normal Paper Print .....	88
3.2.10 A4 Photo Quality Inkjet Paper Print .....	88
3.2.11 A4 Photo Paper/ Glossy Photo Paper print .....	88
3.3 Adjustment Except Adjustment Program .....	89
3.3.1 PG Adjustment .....	89

## Chapter 4 MAINTENANCE

---

4.1 Overview .....	93
4.1.1 Cleaning .....	93
4.1.2 Service Maintenance .....	93
4.1.3 Lubrication .....	95

## Chapter 5 APPENDIX

---

5.1 Exploded Diagram .....	103
5.2 Electrical Circuits .....	103

CHAPTER

1

**TROUBLESHOOTING**

## 1.1 Overview

This chapter describes how to identify troubles in two levels: unit level repair and component level repair. Refer to the flowchart in this chapter to identify the defective unit and perform component level repair if necessary. This chapter also explains motor coil resistance, Sensor specification and error indication.

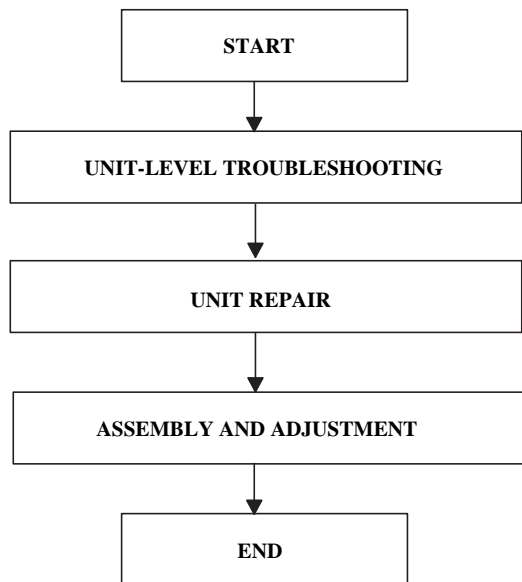

Figure 1-1. Troubleshooting Flowchart

Table 1-1. Motor, Coil Resistance

Motor	Location	Check Point	Resistance
PF Motor (Same as ASF/ Pump Motor)	CN9	Pin 1 and 3 Pin 2 and 4	3.0Ω ±10% (25°C/phase)

Since "CR Motor" and APG Motor are DC motors, the resistance among the electric poles varies. Therefore, judge if it is normal or abnormal based on if there is operation of the motor or not; the resistance values cannot be used to judge the abnormality. However, it is difficult to judge accurately, if it is not clear, replace the motor.

Table 1-2. Sensor check point

Sensor name	Location	Check point	Signal level	Switch mode
PE Sensor	CN4	Pin 1 and 2	More than 2.4V	Off : No paper
			Less than 0.4V	On : Detect paper
PG Sensor	CN5	Pin 1 and 2	More than 2.4V	Off : Anywhere of PG
			Less than 0.4V	On : In process of switching PG
Star Wheel Sensor	CN6	Pin 1 and 2	-	On : ASF mode
			-	Off : CDR mode
CDR Sensor	CN6	Pin 3 and 4	-	Off : No CDR Tray
			-	On : Detect CDR Tray



## 1.2 Troubleshooting with LED/LCD Indications and Status Monitor 3 Message

This section describes the LED/LCD indication, the STM3 message and the error condition when the printer detects an error in each operation such as the power on, the paper loading/feeding and the ink absorption operation.

Table 1-3. LED/LCD Indication and STM3

Printer status	Maintenance LED indication	LCD indication	STM3 message	Condition for error detection
Communication Error	--	--		This error is detected when the printer cannot communicate with the PC properly.
Error before Initial Ink Charge	Blink	Ink Cartridge cannot be recognized. Yellow: T0484 For best result, use genuine EPSON ink.		This error is detected when a defective cartridge is installed in the printer which the Initial Ink Filling is not done yet.

Table 1-3. LED/LCD Indication and STM3

Printer status	Maintenance LED indication	LCD indication	STM3 message	Condition for error detection
<p>Error before ink replacement Cleaning</p>	<p>Blink</p>	<p>Ink Cartridge cannot be recognized. Yellow: T0484 For best result, use genuine EPSON ink.</p>		<p>This error is detected when replacing the Ink Cartridge, if the new cartridge is defective.</p>
<p>Ink Low Condition</p>	<p>Blink</p>	<p>(Blink of Ink Cartridge Icon)</p>	 <p>Note : Printing operation can be performed until it becomes ink end condition even after the error message is displayed on STM3. However, the Head Cleaning operation may not be performed due to the Ink Low condition.</p>	<p>This error is detected when the ink consumption reaches about 90%.</p> <p>(Note) When the Ink Low Condition is detected, the Maintenance LED will blink. The printer will continue to keep this LED status even if a new Ink Cartridge is installed in the Ink Cartridge replacement position. However, this LED status will be reset (LED off) when "Carriage Unit" returns to the home position.</p>

Table 1-3. LED/LCD Indication and STM3

Printer status	Maintenance LED indication	LCD indication	STM3 message	Condition for error detection
Ink Out Error	On	<p>[Stylus Photo R300] Ink out. Yellow: T0484 For best results, use genuine EPSON ink.</p> <p>[Stylus Photo R310] Ink out. Black: T0491 The genuine EPSON ink cartridges listed above are recommended for replacement.</p>		<p>This error is detected in either of the following cases.</p> <ol style="list-style-type: none"> <li>1. The ink consumption reached 100%.</li> <li>2. The Ink Cartridge is faulty. (CSIC memory data error)</li> </ol> <p>(Note) If Ink Out Error is detected, a small amount of ink remains in the Ink Cartridge to protect the Print Head from printing operation.</p>
Paper Out Error	On	<p>[Stylus Photo R300] Paper load error. Load correctly and press Maintenance.</p> <p>[Stylus Photo R310] Paper is not set correctly. Set the paper correctly, then press the Maintenance button.</p>		<p>This error is detected when the top of paper cannot be detected with the PE Sensor in a paper loading.</p>
Paper Jam Error (Including CD/DVD)	On	<p>A paper jam has occurred. See your printer's documentation for information about clearing the jam.</p>		<p>This error is detected when ;</p> <ol style="list-style-type: none"> <li>1. The end of paper cannot be correctly detected with the PE Sensor in a paper loading.</li> <li>2. The rear of CD/DVD cannot be correctly detected with the Star Wheel/CDR Sensor in a CD/DVD loading.</li> </ol>

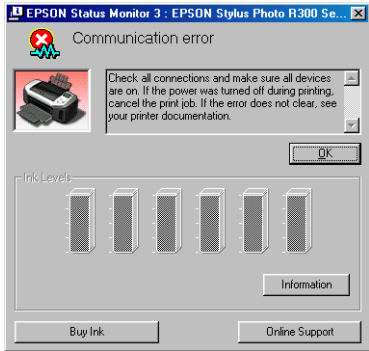
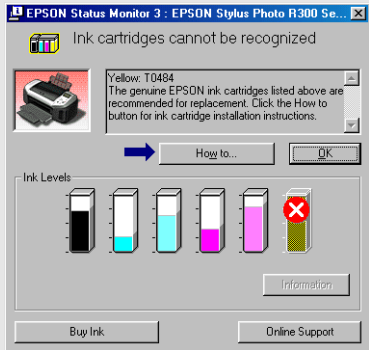
Table 1-3. LED/LCD Indication and STM3



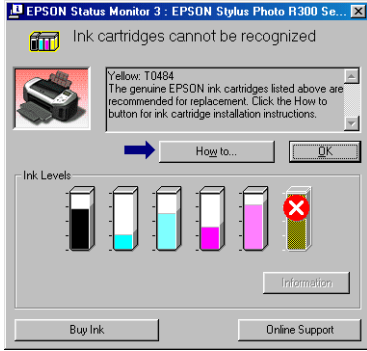
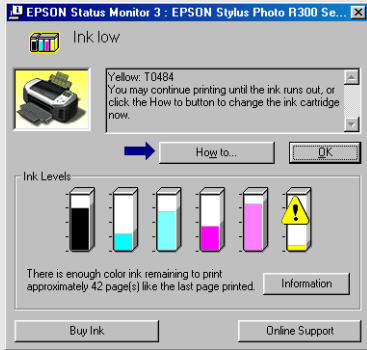

Printer status	Maintenance LED indication	LCD indication	STM3 message	Condition for error detection
No Ink Cartridge	Blink	<p>[Stylus Photo R300] Ink Cartridge cannot be recognized. Yellow: T0484 For best result, use genuine EPSON ink.</p> <p>[Stylus Photo R310] Ink Cartridge cannot be recognized. Black: T0491 The genuine EPSON ink cartridges listed above are recommended for replacement.</p>		<p>This error is detected when ;</p> <ol style="list-style-type: none"> <li>1. The Ink Cartridge is not installed to "Carriage Unit".</li> <li>2. The Ink Cartridge is defective.</li> </ol>
Maintenance Request	On	<p>[Stylus Photo R300] Service required. Printer parts are at end of service life. See printer manual for details.</p> <p>[Stylus Photo R310] Service required. Parts inside your printer are at the end of their service life. See your printer's documentation for details.</p>		<p>This error is detected when the value of the Waste Ink Pad Counter A set in EEPROM reaches its limit (Variable between 20000 and 46750 points).</p>
CD/DVD Guide Error	On	Close the CD/DVD guide.		<p>This error is detected when ;</p> <ol style="list-style-type: none"> <li>1. Paper is present in "ASF Assy.", and "CDR Guide Assy." is open while receiving print data.</li> <li>2. "CDR Guide Assy." opens while printing.</li> <li>3. "CDR Guide Assy." is open while receiving ASF paper feed data.</li> <li>4. Attempting to replace the ink while "CDR Guide Assy." is open.</li> </ol>

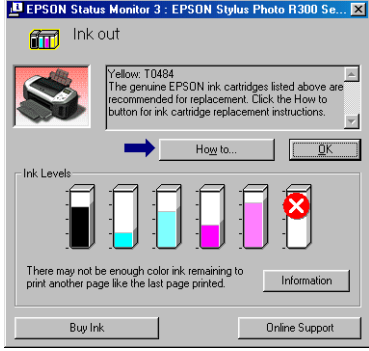
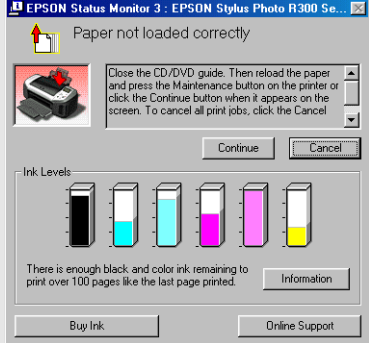
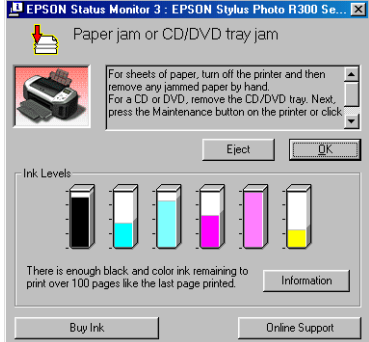
Table 1-3. LED/LCD Indication and STM3

Printer status	Maintenance LED indication	LCD indication	STM3 message	Condition for error detection
CD/DVD Tray Error	On	<p>[Stylus Photo R300] CD/DVD tray load error. Reload tray and press Maintenance.</p> <p>[Stylus Photo R310] The CD/DVD tray is not set correctly. Reload the tray, then press the Maintenance button.</p>		This error is detected when "CD/DVD Tray" cannot be detected while CD/DVD printing.
Memory Card Error (Non supported Memory Card)	On	The inserted card cannot be used with this printer.	No Display	This error is detected when non standardized Memory Card is inserted.
Bluetooth Module Error	On	Bluetooth Photo Print Adapter error. Disconnect the Adapter from the printer, then reconnect it.	No Display	This error is detected when there is no response from Bluetooth Module.
Irregular external device	Blink	The connected device cannot be used. (The warning is displayed for one second every 3 seconds.)	No Display	This error is detected when some non supported device is connected to the port for the external memory device.
Fatal error	On	<p>[Stylus Photo R300] System error. Press and hold both Power and Stop buttons for 7 seconds.</p> <p>[Stylus Photo R310] System error. Simultaneously press and hold the Power and Stop buttons for 7 seconds to turn off the printer.</p>		<p>This error is detected when ;</p> <ol style="list-style-type: none"> <li>"Carriage Unit" cannot move correctly by the external force in each operation.</li> <li>"PF Motor" cannot rotate correctly while "PF Motor" operates.</li> </ol>

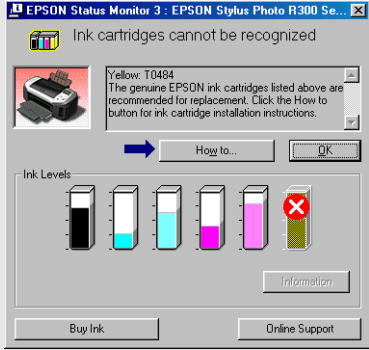
### 1.3 Unit Level Troubleshooting

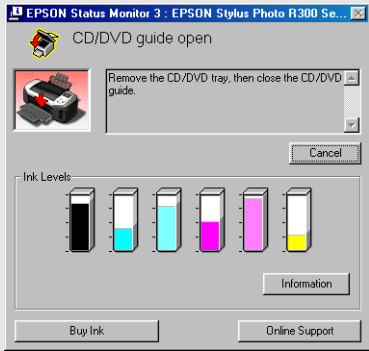
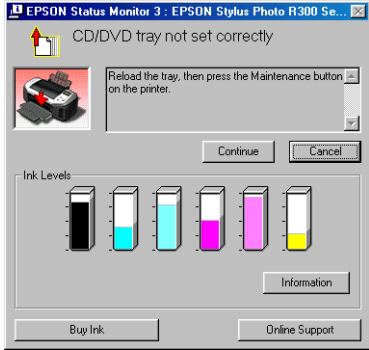
You can identify the troubles by using the checklist in this section after confirming the LED/LCD indication on the control panel or the error message displayed on STM3 of the PC connected to the printer. As a result, you can save the whole repair time. When finding any faulty parts, refer to Chapter 2 "ASSEMBLY/DISASSEMBLY" and replace them. Following tables describe the error conditions (LED/LCD and STM3) and their possible cause.

The following is the example of how to use the tables.

Example) When "Carriage Unit" is out of the home position at the power on timing, the Fatal Error may be caused by the failure of "CR Motor". Moreover, there are 3 possible causes on "CR Motor" failure.

(Note)  
When individual part that makes up "Roller EJ Assy.", "PF Motor" and "Ink System Assy." is defective, replace the Printer Mechanism with a new one basically. However, if an individual part needs to be replaced urgently, execute the necessary operation by referring to Chapter 2 "ASSEMBLY/DISASSEMBLY".

**Table 1-4. Check Points for Communication Error to Each Phenomenon**

Occurrence Timing Position of CR	Phenomenon Detail	Faulty Part/ Part Name	Check Point	Remedy
At power-on Anywhere	When turning on the power, the printer does not operate at all.	Power Supply Board	1. Check if "Power Supply Board Cable" is connected to the CN2 on "Main Board". 2. Check if "Power Supply Board Cable" is not damaged.	1. Connect "Power Supply Board cable" to the CN2 on "Main Board". 2. Replace "Power Supply Board" with a new one. * If the problem still occurs, replace "Main Board".
At operation	When turning on the power, the initialization is performed correctly. However, a Communication Error is displayed on STM3 even transferring the printing job to the printer.	Main Board	1. Check if the correct model name is written in EEPROM on "Main Board".	1. Write proper Market Setting in the Adjustment Program.
		USB Cable	1. Check if "USB Cable" is connected properly between the printer and the PC.	1. Connect the printer and the PC with a "USB Cable".
		Printer Driver	1. Check if the Stylus Photo R300/R310 Printer Driver is used for the printer job.	1. Install the Stylus Photo R300/R310 Printer Driver in the PC.

**Table 1-5. Check Points for Error Before the Initial Ink Charge, Error Before Ink Cartridge Replacement Cleaning and No Ink Cartridge Error**

Occurrence Timing Position of CR	Phenomenon Detail	Faulty Part/ Part Name	Check Point	Remedy
At power-on At HP	The printer does not perform the Initial Ink Charge and the error is displayed on LED and STM3.	Ink Cartridge	1. Check if the Ink Cartridge is normal by installing it in another printer.	1. Replace the Ink Cartridge with a new one.
		Main Board	1. Check if the correct data has been written in the address 5B<H> of EEPROM on "Main Board". (We cannot check it with Adjustment Program of Syllus Photo R300/R310.)	1. Write proper Market Setting in the Adjustment Program.
At power-on Anywhere	The printer does not perform the Ink Replacement Cleaning and the error is displayed on LED and STM3.	Ink Cartridge	1. Check if the Ink Cartridge is normal by installing it in another printer.	1. Replace the Ink Cartridge with a new one.
	The printer does not perform any print operation and the error is displayed on LED and STM3.	Ink Cartridge	1. Check if ink still remains in the Ink Cartridge. 2. Check if the Ink Cartridge is normal by installing it in another printer.	1. Replace the Ink Cartridge with a new one. 2. Replace the Ink Cartridge with a new one.

**Table 1-6. Check Points for Paper Out Error to Each Phenomenon**

Occurrence Timing Position of CR	Phenomenon Detail	Faulty Part/ Part Name	Check Point	Remedy
At operation	"Holder, Shaft, LD Roller" rotates to feed paper, but "Hopper" does not operate.	ASF Assy.	1. Check if "Hopper" works properly while feeding paper.	1. Reassemble "ASF Frame" and "Compression Spring, 2.51" correctly. 

Table 1-6. Check Points for Paper Out Error to Each Phenomenon

Occurrence Timing Position of CR	Phenomenon Detail	Faulty Part/ Part Name	Check Point	Remedy
	When feeding paper, the leading edge of paper is detected properly, but the paper is ejected without being set at the print start position.	ASF Assy.	1. Check if "Roller, Retard Assy." operates properly while feeding paper.	1. Reassemble "Extension Spring, 0.45" located the under side of "Roller, Retard Assy.".  
At operation -	"PF Motor" and "Spur Gear, 37.242" rotate properly, but "Holder, Shaft, LD Roller" does not feed paper. (The driving of "PF Motor" is not transmitted to "Holder, Shaft, LD Roller".)	Holder, Shaft, LD Roller	1. Check if "Extension Spring,0.143" in "Clutch Mechanism" has not come off. 2. Check if "Clutch" has not come off from the dowel of "Shaft, LD Roller". 3. Check if "Clutch Tooth" is not damaged.   4. Check if "Clutch" is not damaged.	1. Reassemble "Extension Spring, 0.143" in "Clutch Mechanism". 2. Reassemble the round portion of "Clutch" on the dowel of "Shaft, LD Roller". 3. Replace "Holder, Shaft, LD Roller" with a new one.
		Paper Guide, Upper (Only HP side)	1. Check if "Paper Guide, Upper" (only HP side) has not come off from "Main Frame".	1. Reassemble "Paper Guide, Upper" to "Main Frame".

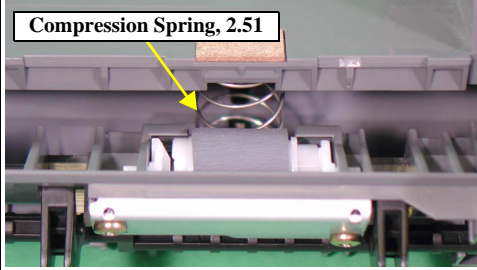

Table 1-6. Check Points for Paper Out Error to Each Phenomenon

Occurrence Timing Position of CR	Phenomenon Detail	Faulty Part/ Part Name	Check Point	Remedy
At operation -	"PF Motor" and "Spur Gear, 37.242" rotate properly, but "Holder, Shaft, LD Roller" does not feed paper. (The drive of "PF Motor" does not propagate to "Holder, Shaft, LD Roller".)	Ink System	1. Check if "Compression Spring, 2.36" of "Lever, Change" does not come off. 	1. Replace "Ink System" with a new one.
	"Holder, Shaft, LD Roller" is not set in the ASF home position and paper is always fed from "ASF Assy."	Ink System	1. Check if the tip of "Lever, Change" is not damaged.	1. Replace "Ink System" with a new one.
	"Holder, Shaft, LD Roller" does not feed paper during the feeding operation. "PF Motor" and "Spur Gear, 37.242" also does not rotate at all.	PF Motor*	1. Check if "PC Connector Cable" is connected to CN9 on "Main Board". 2. Check if the coil resistance of "PF Motor" is approximately 3.0Ω with a tester. Refer to Table 1-1. 3. Check if "PF Motor Connector Cable" is damaged.	1. Connect "PF Motor Connector Cable" to CN9 on "Main Board". 2. Replace "PF Motor" with a new one. 3. Replace "PF Motor" with a new one.
At operation -	"Holder, Shaft, LD Roller" rotates properly, but paper is not fed.	Holder, Shaft LD Roller	1. Check if the surface of "LD Roller" is contaminated with paper dust. 	1. Remove the dust by using a soft brush or soft cloth moistened with alcohol.  * If the problem is not solved, replace "LD Roller" with a new one.

Table 1-7. Check Points for Paper Jam Error to Each Phenomenon

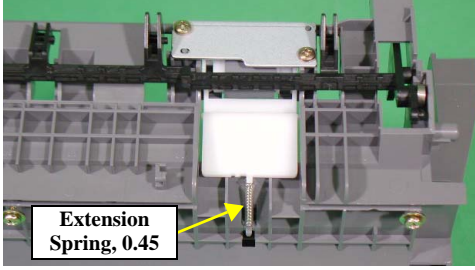
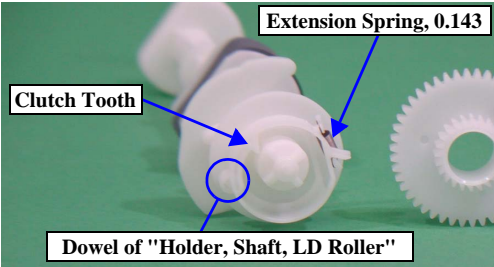
Occurrence Timing Position of CR	Phenomenon Detail	Faulty Part/ Part Name	Check Point	Remedy
At power-on Anywhere	"PF Motor" does not work at all.	PF Motor	<ol style="list-style-type: none"> <li>1. Check if "PF Motor Connector Cable" is connected to CN9 on "Main Board".</li> <li>2. Check if the coil resistance of "PF Motor" is approximately 3.0Ω with a tester. Refer to Table 1-1.</li> <li>3. Check if "PF Motor Connector Cable" is damaged.</li> </ol>	<ol style="list-style-type: none"> <li>1. Connect "PF Motor Connector Cable" to CN9 on "Main Board".</li> <li>2. Replace "PF Motor" with a new one.</li> <li>3. Replace "PF Motor" with a new one.</li> </ol>
	Paper feeding operation is performed normally, but paper is not sent into the printer.	ASF Assy.	<ol style="list-style-type: none"> <li>1. Check if "Roller, Retard Assy." operates properly while feeding paper.</li> </ol>	<ol style="list-style-type: none"> <li>1. Reassemble "Extension Spring, 0.45" located the under side of "Roller, Retard Assy.".</li> </ol> 
		PE Sensor	<ol style="list-style-type: none"> <li>1. Check if "Torsion Spring, 0.22" is not unfastened from "PE Sensor Lever".</li> </ol>  <ol style="list-style-type: none"> <li>2. Check if "PE Sensor Cable" is not unfastened.</li> <li>3. Check if "PE Sensor Cable" is correctly mounted on "Holder, Shaft, LD Roller".</li> <li>4. Check if "PE Sensor Cable" is not damaged.</li> </ol>	<ol style="list-style-type: none"> <li>1. Reassemble "Torsion Spring, 0.22"</li> <li>2. Connect "PE Sensor" Connector to CN4 on "Main Board".</li> <li>3. Remount "PE Sensor Cable" correctly.</li> <li>4. Replace "PE Sensor" with a new one.</li> </ol>

Table 1-7. Check Points for Paper Jam Error to Each Phenomenon

Occurrence Timing Position of CR	Phenomenon Detail	Faulty Part/ Part Name	Check Point	Remedy
At operation Out of HP	"Carriage Unit" moves to the home position properly when turning on the power. Then paper feeding operation is performed normally, but paper is not sent into the printer.	PE Sensor*	<ol style="list-style-type: none"> <li>1. Check if "Torsion Spring, 0.22" for "PE Sensor Lever" is not unfastened.</li> <li>2. Check if "PE Sensor Cable" is correctly mounted on "Holder, Shaft, LD Roller".</li> </ol>	<ol style="list-style-type: none"> <li>1. Reassemble "Torsion Spring, 0.22".</li> <li>2. Remount "PE Sensor Cable" correctly.</li> </ol>
	When feeding paper, the leading edge of paper is detected properly, but the paper is ejected without being set at the print start position. At this time, the next paper is fed to "PE Sensor Lever".	ASF Assy.	<ol style="list-style-type: none"> <li>1. Check if "Roller, Retard Assy." operates properly while feeding paper.</li> </ol>	<ol style="list-style-type: none"> <li>1. Reassemble "Extension Spring, 0.45" back of "Roller, Retard Assy."</li> </ol> 
At operation		Frame EJ Assy.**	<ol style="list-style-type: none"> <li>1. Check if "Star Wheels" have not come off.</li> <li>2. Check if "Frame EJ Assy." is correctly assembled.</li> <li>3. Check if "Frame EJ Assy." is not transformed toward downward.</li> </ol>	<ol style="list-style-type: none"> <li>1. Reassemble "Star Wheels" correctly.</li> <li>2. Reassemble "Frame EJ Assy." correctly.</li> <li>3. Replace "Frame EJ Assy." with a new one.</li> </ol>
		Paper Guide, Front	<ol style="list-style-type: none"> <li>1. Check if "porous pad" of "Paper Guide, Front" has not come off.</li> </ol>	<ol style="list-style-type: none"> <li>1. Remount "porous pad" correctly.</li> </ol>
	The leading edge of paper does not go through between "Roller EJ Assy." and "Star Wheels".	Roller EJ Assy.	<ol style="list-style-type: none"> <li>1. Check if "Roller EJ Assy." is correctly assembled.</li> <li>2. Check if "Spur Gear, 41.48" has not come off.</li> </ol> 	<ol style="list-style-type: none"> <li>1. Reassemble "Roller EJ Assy." correctly onto "Printer Mechanism".</li> <li>2. Reattach "Spur Gear, 41.48" to "Roller EJ Assy." correctly.</li> </ol>

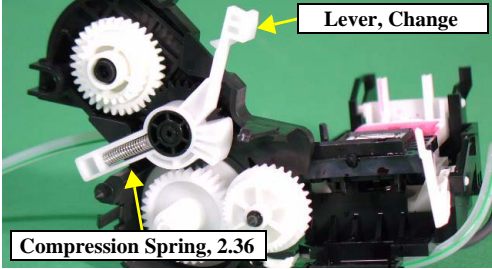
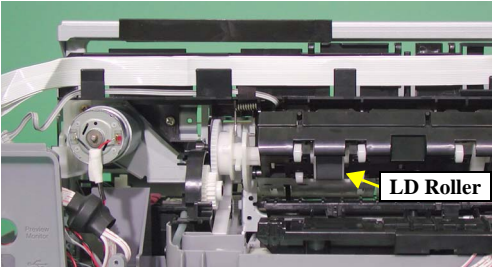
Table 1-7. Check Points for Paper Jam Error to Each Phenomenon

Occurrence Timing Position of CR	Phenomenon Detail	Faulty Part/ Part Name	Check Point	Remedy
At operation -	The leading edge of paper is not sent to "PF Roller".	Paper Guide, Upper	1. Check if "Paper Guide, Upper" has not come off from "Main Frame". 	1. Reattach "Paper Guide, Upper" to "Main Frame".

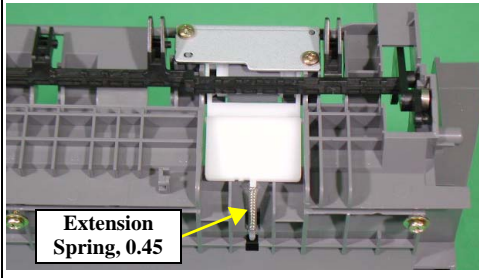
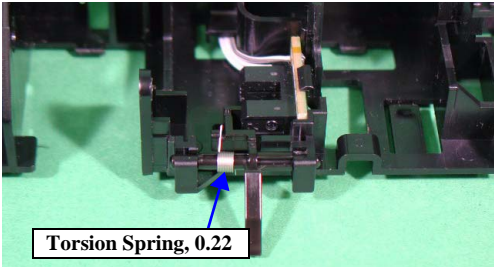
\* "Carriage Unit" can move to the home position even if "Extension Spring, 0.22" has come off or "PE Sensor" is not set in the correct position. However, in the next operation, a Paper Jam Error will be detected since "PE Sensor Lever" will maintain the High signal status.

\*\* There some cases where the jammed paper may damage "Print Head" by contacting the surface of "Print Head nozzle" when a Paper Jam Error occurs in each operation.

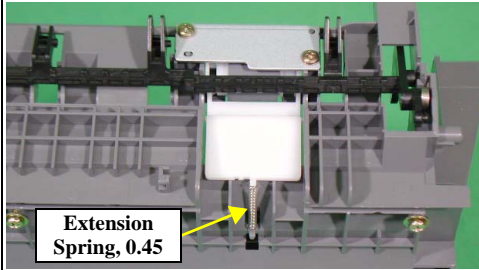
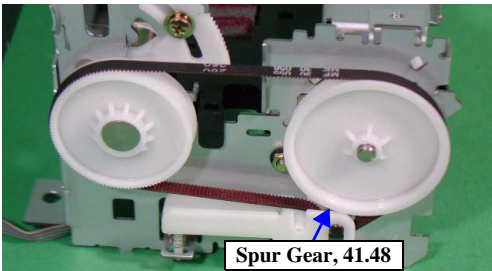
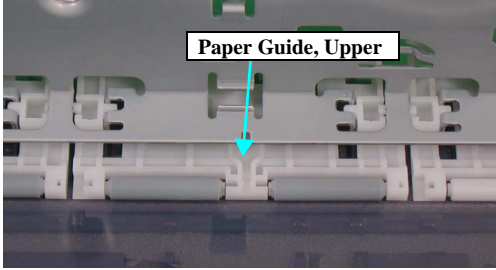
Table 1-8. Check Points for CD/DVD Guide Error to Each Phenomenon

Occurrence Timing Position of CR	Phenomenon Detail	Faulty Part/ Part Name	Check Point	Remedy
At power-on At HP	An error occurs even if "CDR Guide Assy." is closed when turning on the power.	Housing, Middle	1. Check if the contact point of "Housing, Middle" with "Star Wheel/CDR Sensor" is not cracked. 	1. Replace "Housing, Middle" with a new one.
		Star Wheel/ CDR Sensor	1. Check if "Star Wheel/CDR Sensor" is connected to CN6 on "Main Board".  2. Check if "Star Wheel/CDR Sensor" is not damaged. 3. Check if "Star Wheel/CDR Sensor" cable is not cut off.	1. Connect "Star Wheel/CDR Sensor" to CN6 on "Main Board". 2. Replace "Star Wheel/CDR Sensor" with a new one. 3. Replace "Star Wheel/CDR Sensor" with a new one.
		Main Board	1. Check if any device on "Main Board" is not damaged.	1. Replace "Main Board" with a new one.

Table 1-9. Check Points for CD/DVD Tray Error to Each Phenomenon

Occurrence Timing Position of CR	Phenomenon Detail	Faulty Part/ Part Name	Check Point	Remedy
When printing CDR/DVDR	An error occurs even though "CDR Tray" is set when printing CDR/DVDR.	CDR Tray	1. Check if the contact point of "CDR Tray" with "CDR Tray Sensor" is not cracked. 	1. Replace "CDR Tray" with a new one.
		CDR Tray Sensor	1. Check if "CDR Tray Sensor" is connected to CN6 on "Main Board".  2. Check if "CDR Tray Sensor" is not damaged. 3. Check if "CDR Tray Sensor Connector Cable" is not cut off.	1. Connect "CDR Tray Sensor" to CN6 on "Main Board". 2. Replace "CDR Tray Sensor" with a new one. 3. Replace "CDR Tray Sensor" with a new one.
		Main Board	1. Check if any device on "Main Board" is not damaged.	1. Replace "Main Board" with a new one.

Table 1-10. Check points for Memory Card Error to Each Phenomenon

Occurrence Timing Position of CR	Phenomenon Detail	Faulty Part/ Part Name	Check Point	Remedy
When inserting Memory Card	The Memory Card is not detected, and an error is displayed on LED and STM3.	Memory Card	<ol style="list-style-type: none"> <li>1. Check if the Memory Card can be supported.</li> <li>2. Check if the Memory Card is not damaged.</li> </ol>	<ol style="list-style-type: none"> <li>1. Replace the Memory Card with a Memory Card which will be supported.</li> <li>2. Replace the Memory Card with a new one.</li> </ol>
		Main Board	<ol style="list-style-type: none"> <li>1. Check if there is no damage on the slot pin of the loading slot for Memory Cards.</li> <li>2. Check if any device on "Main Board" is damaged.</li> </ol>	<ol style="list-style-type: none"> <li>1. Replace "Main Board" with a new one.</li> <li>2. Replace "Main Board" with a new one.</li> </ol>

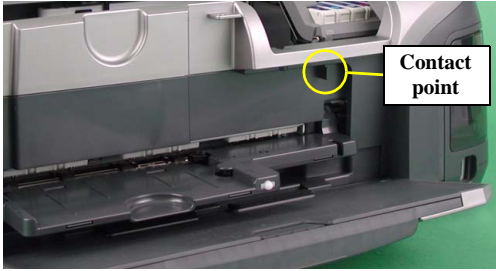
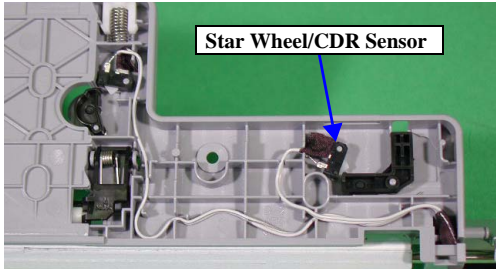
**Table 1-11. Check Points for Fatal Error to Each Phenomenon**

Occurrence Timing Position of CR	Phenomenon Detail	Faulty Part/ Part Name	Check Point	Remedy
At power-on Out of HP	"CR Motor" does not work at all when turning on the power.	CR Motor	1. Check if "CR Motor Connector Cable" is connected to CN8 on "Main Board". 2. Check if "CR Motor Connector Cable" is not damaged.	1. Connect "CR Motor Connector Cable" to CN8 on "Main Board". 2. Replace "CR Motor" with a new one.
	"Carriage Unit" strikes on "Lever, Change" which is leaning forward when turning on the power.	PF Motor	1. Check if "PF Motor Connector Cable" is connected to CN9 on "Main Board". 2. Check if the resistance of "PF Motor" is approximately 3.0Ω using a tester. Refer to Table 1-1. 3. Check if "PF Motor Connector Cable" is not damaged.	1. Connect "PF Motor Connector Cable" to CN9 on "Main Board". 2. Replace "PF Motor" with a new one. 3. Replace "PF Motor" with a new one.
		Ink System	1. Check if "Compression Spring, 2.36" of "Lever, Change" has not come off. 	1. Replace "Ink System" with a new one.
"Carriage Unit" strikes on "Paper Guide, Upper" which has come off from "Main Frame" when turning on the power.	Paper Guide, Upper	1. Check if "Paper Guide, Upper" has not come off from "Main Frame". 	1. Reassemble "Paper Guide, Upper" to "Main Frame".	
At power-on Anywhere	"Carriage Unit" strikes on the right side of "Main Frame" when turning on the power.	CR Scale	1. Check if "CR Scale" has not come off or it properly passes through the slit of "CR Encoder Sensor Board".	1. Reassemble "CR Scale" correctly. * If the problem is not solved, replace "Main Board" with a new one.

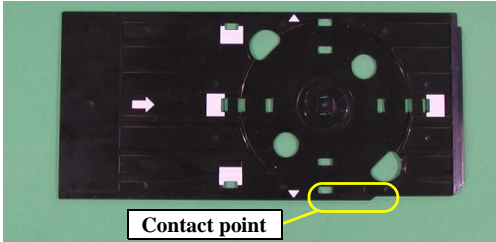
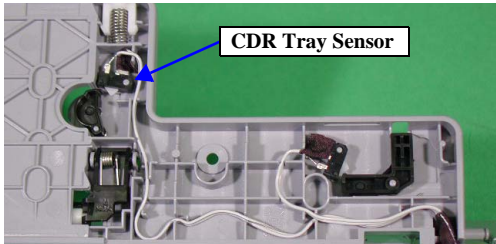
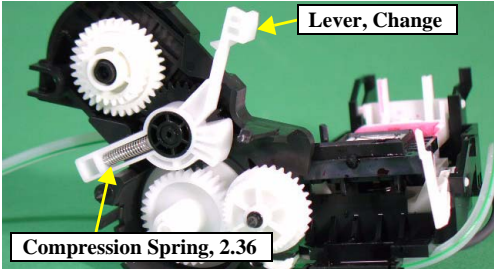
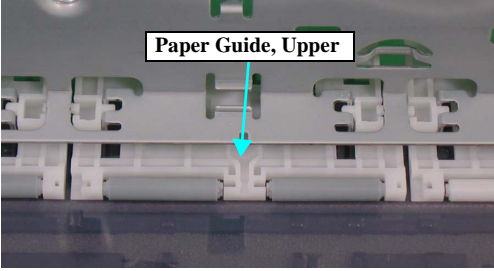

**Table 1-12. Check Points When More Than One Paper is Fed Constantly Without LED/STM3's Error Notifications**

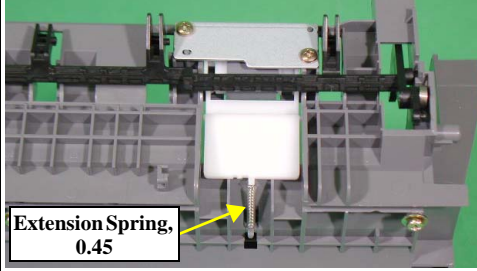
Occurrence Timing Position of CR	Phenomenon Detail	Faulty Part/ Part Name	Check Point	Remedy
At operation	The printer always feeds more than one sheet of paper without LED/STM3's error notifications.	ASF Assy.	1. Check if "Roller, Retard Assy." works correctly while feeding paper.	1. Reassemble "Extension Spring, 0.45" on the back of "Roller, Retard Assy." 

**Table 1-13. Check Points for Abnormal Sound**

Occurrence Timing Position of CR	Phenomenon Detail	Faulty Part/ Part Name	Check Point	Remedy
Any time Anywhere	Abnormal sound is heard in spite of the normal print operation at the first power on or some other time.	Carriage Unit	1. Check if there is enough grease on "CR Guide Shaft".	1. Wipe the remaining grease off "CR Guide Shaft" and reapply some grease.
		Ink System	1. Check if "Lever, Change" moves smoothly.	1. Replace "Ink System" with a new one.
	The bottom of "Carriage Unit" touches the surface of "Front Frame".	Frame EJ Assy.	1. Check if "Frame EJ Assy." is not warping upward.	1. Replace "Frame EJ Assy." with a new one.
	"Carriage Unit" strikes on "Paper Guide, Upper" while "Carriage Unit" is working.	Paper Guide, Upper	1. Check if "Paper Guide, Upper" has not come off from "Main Frame".	1. Reassemble "Paper Guide, Upper" to "Main Frame".

Table 1-14. Check Points for Defective Print Quality

Occurrence Timing Position of CR	Phenomenon Detail	Faulty Part/ Part Name	Check Point	Remedy
<p>At operation</p> <p>-</p>	<p>[Phenomenon 1] When the printer is performing the Cleaning task, the ink is not drained into "Waste Ink Pad" in spite of the correct function of "Pump Unit". The ink is not absorbed from "Print Head" to the Cap at all.</p> <p>[Phenomenon 2] When the printer is performing the Cleaning task, the ink is drained into "Waste Ink Pad". (This indicates that both of "Pump Unit" and "Cap Unit" are working correctly.) However, missing dots is not solved at certain nozzles even performing the Cleaning several times.</p> <p>[Phenomenon 3] When the printer is performing the Cleaning task, the ink is drained into "Waste Ink Pad". (This indicates that both of "Pump Unit" and "Cap Unit" work correctly.) However, the wiping function is not executed correctly and some different colors of ink mix together.</p> <p>[Phenomenon 4] When the printer is performing the Cleaning task, the ink is drained into "Waste Ink Pad". However, some missing dots occurs while printing.</p> <p>[Phenomenon 5] When the printer is performing the Cleaning task, the ink is drained into "Waste Ink Pad". However, missing dot occurs and the points where it occurs varies in every movement of the Cleaning.</p>	<p>Ink System</p>	<ol style="list-style-type: none"> <li>1. Check if there is not any foreign matter on the sealing rubber on "Cap Unit".</li> </ol>  <ol style="list-style-type: none"> <li>2. Check if the sealing rubber on "Cap Unit" is not damaged.</li> <li>3. Check if "Compression Spring, 2.53" is properly attached in "Cap Unit".</li> </ol>  <ol style="list-style-type: none"> <li>4. Check if "Pump Tube" is properly connected to the bottom of "Cap Unit".</li> </ol>  <ol style="list-style-type: none"> <li>5. Check if "Extension Spring, 0.788" has not come off from "Slider Cap".</li> <li>6. Check if "Extension Spring, 0.441" has not come off from "Slider Cap".</li> </ol> 	<ol style="list-style-type: none"> <li>1. Remove the foreign matter from the sealing rubber.</li> <li>2. Replace "Ink System" with a new one.</li> <li>3. Replace "Ink System" with a new one.</li> <li>4. Replace "Ink System" with a new one.</li> <li>5. Reassemble "Extension Spring, 0.788" correctly.</li> <li>6. Reassemble "Extension Spring, 0.441" correctly.</li> </ol>

Table 1-14. Check Points for Defective Print Quality

Occurrence Timing Position of CR	Phenomenon Detail	Faulty Part/ Part Name	Check Point	Remedy
At operation	<p>[Phenomenon 6] When the Cleaning is working, the ink is drained into "Waste Ink Pad". However, some missing dots and out of alignment occur while printing. They are not solved even executing the Cleaning several times.</p> <p>* If the problem is not solved, replace "Main Board" with a new one.</p>	Ink System	7. Check if "Slider Lock Lever" is not damaged.	7. Replace "Ink System" with a new one.
		Ink Cartridge	1. Check if ink still remains in Ink Cartridge	1. Replace the Ink Cartridge with a new one.
		Print Head	<ol style="list-style-type: none"> <li>1. Check if there is not any foreign matter on the nozzle surface of "Print Head".</li> <li>2. Check if "Head FFC" is connected to CN7 and CN8 on "Main Board", or to the board on "Print Head".</li> <li>3. Check if "Head FFC" is not damaged.</li> <li>4. Check if each segment prints correctly with the Nozzle Check Pattern.</li> </ol>	<ol style="list-style-type: none"> <li>1. Perform the wiping operation. Replace "Wiper" when "Wiper" is deformed or contaminated awfully.</li> <li>2. Securely connect "Head FFC" to "Main Board" or the board on "Print Head".</li> <li>3. Replace "Head FFC" with a new one.</li> <li>4. Perform Head Cleaning and check the Nozzle Check Pattern.</li> </ol> <p>* If the problem is not solved, replace "Print Head" with a new one.</p>
	<p>Banding phenomenon occurs in a direction perpendicular to "Carriage Unit" movement getting uneven print density.</p> <div data-bbox="421 820 583 1034" style="text-align: center;"> </div> <p>(Note) If the problem is not solved, replace "CR Motor" with a new one.</p>	Carriage Unit	<ol style="list-style-type: none"> <li>1. Check if there is no foreign matter on the surface of "CR Guide Shaft".</li> <li>2. Check if there is no damage on the surface of "CR Guide Shaft".</li> <li>3. Check if there is enough grease on the surface of "CR Guide Shaft".</li> <li>4. Check if "CR Guide Shaft" is properly connected to "Main Frame" with the fixing spring of "CR Guide Shaft".</li> </ol>	<ol style="list-style-type: none"> <li>1. Remove the foreign matter on "CR Guide Shaft".</li> <li>2. Replace "CR Guide Shaft" with a new one.</li> <li>3. Wipe the surface of "CR Guide Shaft" with a dry soft cloth, and then apply G-63 to it. Refer to Section 4.1.3.</li> <li>4. Reassemble "CR Guide Shaft" correctly.</li> </ol>

Table 1-14. Check Points for Defective Print Quality

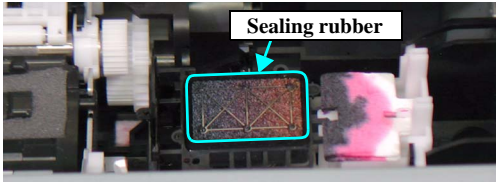
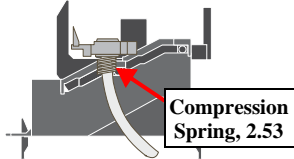
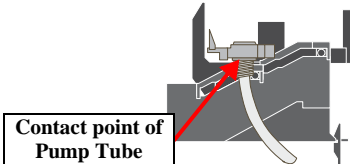
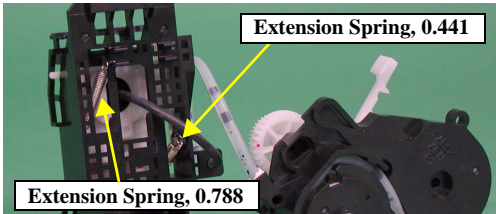

Occurrence Timing Position of CR	Phenomenon Detail	Faulty Part/ Part Name	Check Point	Remedy
At operation	Banding phenomenon occurs in a direction perpendicular to "Carriage Unit" movement getting uneven print density.	Frame EJ Assy.	1. Check if the surface of "Frame EJ Assy." is precisely horizontal.	1. Replace "Frame EJ Assy." with a new one.
		Print Head	1. Check if "Print Head" prints correctly with the Nozzle Check Pattern.	1. Perform the Head Cleaning, then check the Nozzle Check Pattern. * If the problem is not solved, replace "Print Head" with a new one.
	Banding phenomenon occurs in a direction horizontally to "Carriage Unit" movement.	PF Roller	1. Check if there is not any foreign matter on the surface of "PF Roller". 2. Check if "PF Roller" is not damaged. 3. Check if "Spur Gear, 37.242" is not damaged or broken.	1. Clean the surface of "PF Roller". 2. Replace "Printer Mechanism" with a new one. 3. Replace "Printer Mechanism" with a new one.
		Printer Driver and Special Paper	1. Check if appropriate paper is used in accordance with the Printer Driver settings.	1. Use the appropriate type of paper in accordance with the Printer Driver.
	(Note) If the problem is not solved, replace "PF Motor" with a new one.	Print Head	1. Check if "Print Head" prints correctly with the Nozzle Check Pattern.	1. Perform the Head Cleaning, then check the Nozzle Check Pattern. * If the problem is not solved, replace "Print Head" with a new one.
	Banded stripes appear in a direction horizontally to "Carriage Unit" movement.	Paper Guide, Front	1. Check if "porous pad" in front of "Paper Guide, Front" has not come off.	1. Reattach "porous pad".
	These stripes appear when the print paths overlap each other.			

Table 1-14. Check Points for Defective Print Quality

Occurrence Timing Position of CR	Phenomenon Detail	Faulty Part/ Part Name	Check Point	Remedy
At operation -	One or more than one traces of "Star Wheels" appear in a direction perpendicular to "Carriage Unit" movement. 	Frame EJ Assy.	1. Check if "Star Wheels" have not come off. 2. Check if the surface of "Frame EJ Assy." is mounted horizontally.	1. Reassemble "Star Wheels" correctly. 2. Replace "Frame EJ Assy." with a new one.
	Normal printing task is performed; however, the top margin is less than usual.	Holder, Shaft, LD Roller	1. Check if any paper dust has not adhered to the surface of "LD Roller". 	1. Remove the dust by using a soft brush or soft cloth moistened with alcohol. * If the problem is not solved, replace "Holder, Shaft, LD Roller" with a new one.
	The print is light and thin.	Printer Driver and Special Paper	1. Check if appropriate paper is used in accordance with the Printer Driver settings.	1. Use the appropriate type of paper in accordance with the Printer Driver settings.
		Print Head	1. Check if the correct Head ID has been input in EEPROM by using the Adjustment Program.	1. Input 15-digit ID code of the Head ID in EEPROM by using the Adjustment Program

Table 1-14. Check Points for Defective Print Quality

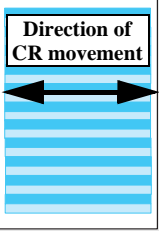
Occurrence Timing Position of CR	Phenomenon Detail	Faulty Part/ Part Name	Check Point	Remedy
At operation -	The paper is stained with the ink.	Frame EJ Assy.	1. Check if there is any ink adhesion on "Frame EJ Assy.".	1. Clean the ink adhesion on "Frame EJ Assy." with a soft cloth.
			1. Check if "Frame EJ Assy." has not warped upward.	1. Replace "Frame EJ Assy." with a new one.
		Paper Guide, Front	1. Check if there is any ink adhesion on "Paper Guide, Front".	1. Clean the ink adhesion on "Paper Guide, Front" with a soft cloth.
			2. Check if "porous pad" of "Paper Guide, Front" has not come off.	2. Reattach "porous pad".
		Roller EJ Assy.	1. Check if there is any ink adhesion on "Roller EJ Assy.".	1. Clean the ink adhesion on "Roller EJ Assy." with a soft cloth.
		Paper Guide, Upper	1. Check if there is any ink adhesion on "Paper Guide, Upper".	1. Clean the ink adhesion on "Paper Guide, Upper" with a soft cloth.
		PF Roller	1. Check if there is any ink adhesion on "PF Roller".	1. Clean the ink adhesion on "PF Roller" with a soft cloth.
	Ink System	1. Check if the wiping operation has been performed correctly.	1. Replace "Ink System" with a new one.	
Print Head	1. Check if there is any ink adhesion on "Print Head Cover".	1. Clean the ink adhesion on "Print Head Cover" with a soft cloth.		
	The upper edge of the paper gets creased.	ASF Assy.	1. Check if "Hopper Pad" is stuck to "Hopper" correctly.	1. Replace "ASF Assy." with a new one.

CHAPTER

2

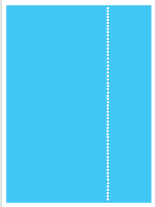
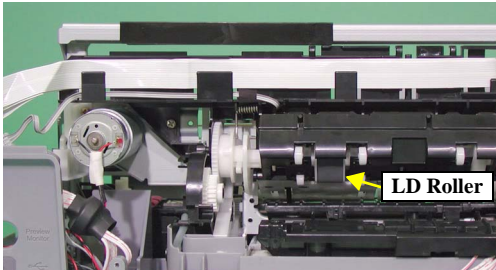
**DISASSEMBLY AND ASSEMBLY**

## 2.1 Overview

This section describes procedures for disassembling the main components of Stylus Photo R300/R310. Unless otherwise specified, disassembly units or components can be reassembled by reversing the disassembly procedure.

"WARNING" indicates procedures which may result in damage, injury or involving human lives if you don't take extra care.

"CAUTION" indicates precautions for any disassembly or assembly procedures.

"CHECK POINT" indicates points to be checked.

"REASSEMBLY" indicates reassembling procedures which are different from the reverse order of the disassembling.

"ADJUSTMENT REQUIRED" indicates required adjustments after the assembly and the disassembly.

Read precautions described in the next section before starting.

### 2.1.1 Precautions

Before starting the disassembling/reassembling work of this product, always read the descriptions under the following headings "WARNING" and "CAUTION" carefully.



- **Disconnect the power cable before disassembling or assembling the printer.**
- **If you need to work on the printer with power applied, strictly follow the instructions in this manual.**
- **Wear protective goggles to protect your eyes from ink. If ink gets in your eye, flush the eye with fresh water and see a doctor immediately.**
- **Always wear gloves for disassembly and reassembly to avoid injury from sharp metal edges.**
- **To protect sensitive microprocessors and circuitry, use static discharge equipment, such as anti-static wrist straps, when accessing internal components.**
- **Never touch the ink or wasted ink with bare hands. If ink comes into contact with your skin, wash it off with soap and water immediately. If you have a skin irritation, consult a physician.**
- **When reassembling the waste ink pads and tray, always make sure that the waste ink tube is fitted correctly in the specified place. Fitting the ink tube in other than the specified position can cause ink leakage.**



- **Avant de commencer, assure vous que l'imprimante soit eteinte et que le cordon d'alimentation soit debranche.**
- **Veillez a jeter les piles usagees selon le reglement local.**



- **Risque d'explosion si la pile est remplacée incorrectement. Ne remplacer que par une pile du même type ou d'un type équivalent recommandé par le fabricant. Eliminer les piles déchargées selon les lois et les règles de sécurité en vigueur.**



- **When transporting the printer after installing the ink cartridge, be sure to pack the printer for transportation without removing the ink cartridge.**
- **Use only recommended tools for disassembling, assembling or adjusting the printer. (Refer to Table 2-1 "Tool List".)**
- **Observe the specified torque when tightening screws.**
- **Use the specified lubricants and adhesives. (Refer to Chapter 4 for details.)**
- **Make the specified adjustments when you disassemble the printer. (Refer to Chapter 3 for details.)**



## 2.1.2 Tools

Use only specified tools to avoid damaging the printer.

**Table 2-1. Tools**

Tool Name	Supplier	Code
Phillips Screw Driver (No. 0)	EPSON	1080531
Phillips Screw Driver (No. 1)	EPSON	1080530
Phillips Screw Driver (No. 2)	EPSON	1080532
Tweezers	EPSON	1080561
Acetate Tape	EPSON	1003963

## 2.1.3 Pre-shipment Checks

When returning this product to the user after completing printer repair, check that the work is complete using the following table.

**Table 2-2. Service Completion Pre-shipment Check List**

Classification	Item	Check Point	Status	
Main Unit	Self-test	Is the operation normal?	<input type="checkbox"/> Checked <input type="checkbox"/> Not necessary	
	On-line Test	Is the printing successful?	<input type="checkbox"/> Checked <input type="checkbox"/> Not necessary	
	Print Head	Is ink discharged normally from all the nozzles?	<input type="checkbox"/> Checked <input type="checkbox"/> Not necessary	
	Carriage Mechanism	Does it move smoothly?	<input type="checkbox"/> Checked <input type="checkbox"/> Not necessary	
		Is there any abnormal noise during its operation?	<input type="checkbox"/> Checked <input type="checkbox"/> Not necessary	
		Is there any dirt or foreign objects on the CR Guide Shaft?	<input type="checkbox"/> Checked <input type="checkbox"/> Not necessary	
		Is the CR Motor at the correct temperature? (Not too heated?)	<input type="checkbox"/> Checked <input type="checkbox"/> Not necessary	
	Paper Feeding Mechanism	<ul style="list-style-type: none"> <li>• Is paper fed smoothly?</li> <li>• No paper jamming?</li> <li>• No paper skew?</li> <li>• No multiple feeding?</li> <li>• No abnormal noise?</li> </ul>	<input type="checkbox"/> Checked <input type="checkbox"/> Not necessary	
		Is the PF Motor at correct temperature?	<input type="checkbox"/> Checked <input type="checkbox"/> Not necessary	
		Is the paper path free of any obstructions?	<input type="checkbox"/> Checked <input type="checkbox"/> Not necessary	
	Adjustment	Specified Adjustment	Are all the adjustment done correctly?	<input type="checkbox"/> Checked <input type="checkbox"/> Not necessary

Table 2-2. Service Completion Pre-Shipment Check List

Classification	Item	Check Point	Status
Lubrication	Specified Lubrication	Are all the lubrication made at the specified points?	<input type="checkbox"/> Checked <input type="checkbox"/> Not necessary
		Is the amount of lubrication correct?	<input type="checkbox"/> Checked <input type="checkbox"/> Not necessary
Function	ROM Version	Is it the latest version? Version:	<input type="checkbox"/> Checked <input type="checkbox"/> Not necessary
Packing	Ink Cartridge	Are the ink cartridges installed correctly?	<input type="checkbox"/> Checked <input type="checkbox"/> Not necessary
	Protective Materials	Have all relevant protective materials been attached to the printer?	<input type="checkbox"/> Checked <input type="checkbox"/> Not necessary
Others	Attachments, Accessories	Have all of the accessories been included in the package?	<input type="checkbox"/> Checked <input type="checkbox"/> Not necessary

## 2.2 Caution regarding assembling/disassembling the printer mechanism, and how to ensure the quality of reassembled product

For the existing Low End models, it is basically forbidden to remove "Housing, Lower" from "Printer Mechanism". This is because the strength of "Frame, Main" is not strong enough, therefore, "Frame, Main" may be transformed when removing/reinstalling it from/to "Housing, Lower".

For that reason, when replacing "Ink System" or "PF Motor", it is recommended to replace not only "Housing, Lower" but also "Printer Mechanism".

For this printer, it is necessary that "Housing, Lower" be removed from "Printer Mechanism" when replacing "Waste ink Pads" or "Ink System".

Therefore, this chapter specifies the disassembly/assembly of "Printer Mechanism" which "Housing, Lower" has been taken out in order to secure the quality of the repaired items.

### □ Caution for disassembly/assembly of Printer Mechanism

1. "Printer Mechanism" with "Housing, Lower"
  - Do not hold "Guide Plate, CR" ⇒ Transforming of "Frame, Main" and "Guide Plate, CR" may give some bad influence to PG or printing.
  - Do not touch "CR Guide Shaft" and/or the surface of the head nozzle.
2. "Printer Mechanism" without "Housing, Lower"
  - Manage the standard values for installation. (See below)
  - First, remove "Support Plate, Frame, Main". Then, remove "Roller PF Assy.", "Roller EJ Assy." and "Paper Guide, Front".
  - Make sure to manage "Waste Ink Tube".
  - Be careful with the interconnection of "Star Wheel/CDR Sensor" connector cable.
  - Assemble "Cam, CR, Left" while gearing with the APG gear.

### ■ Management of the reference position for installation

[Reason]

Accurate installation for each component of "Printer Mechanism" is on a basis of "Housing, Lower".

[Support for Service]

Check if there is no gap between "Frame, Main" and "Housing, Lower".

[Reference]

In order to ensure the accuracy for installation, it is necessary to manage the reference position for installation in X, Y and Z direction.

[X-axis]

- Check if "Frame, Main" is correctly set to the groove of "Housing, Lower".
- Check if there is no gap between "Frame, Main" and "Housing, Lower".

[Y-axis]

- Check if the slot of "Frame, Main" is correctly attached to the projection of "Housing, Lower".

[Z-axis]

- Check if there is no gap between "Frame, Main" and "Housing, Lower".
- Check if correctly secured with the hooks (2 on the left, 1 on the right, 1 on the right front) of "Printer Mechanism".

### ■ Management of the perpendicular accuracy of "Guide Plate, CR" (The standards of the guide rail's perpendicular direction is on the basis of the hooks of "Carriage Unit" and "Print Head".)

[Reason]

Deformation of "Guide Plate, CR" may cause the defective print/operation.

[Support for Service]

Specify the correct raising position for "Main Frame" so that it will not be deformed.

- How to install "ASF Assy.", "Main Board" and "Paper Guide, Upper"

[Reason]

When installing these three components, too much force can be given to "Frame, Main", therefore, it may be deformed and cause the defective print/operation.

[Support for Service]

Hold the opposite side of the components securely, when installing them.

### 3. CDR Guide Assy.

- Management of the level accuracy of "CDR Guide Assy."

[Reason]

Deformation of "CDR Guide Assy." may cause the defective print.

[Support for Service]

Disassemble/assemble carefully "CDR Guide Assy.".

### □ How to secure the quality for reassembled products

It can be judged that the quality for the reassembled products is guaranteed if the printing test with the Adjustment program is successful.

## 2.3 Disassembly

The following flowchart shows the order of disassembling procedure. When disassembling any unit, refer to the page number shown in the flowchart.

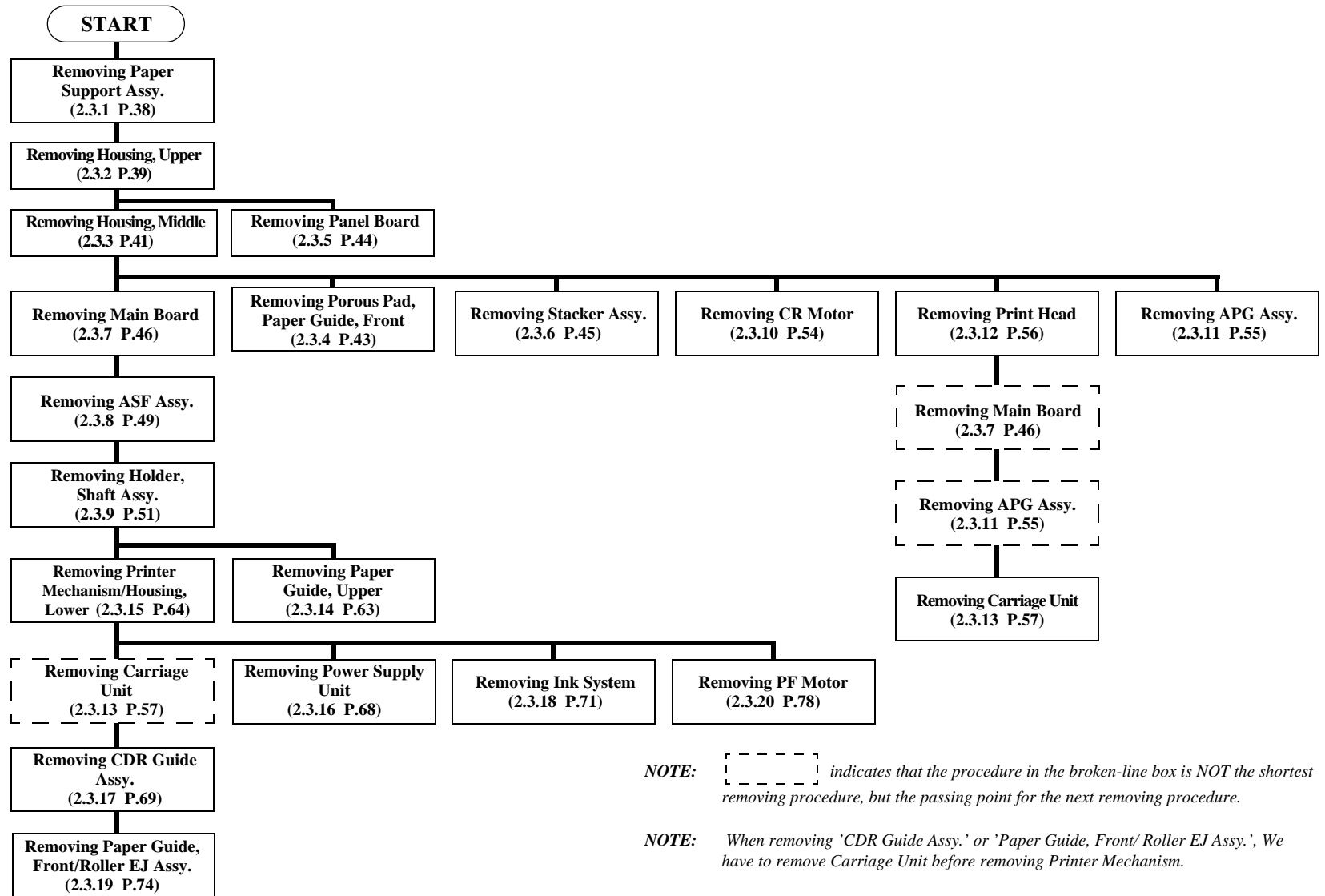

Figure 2-1. Removing Procedure Flowchart

## 2.3.1 Removing Paper Support Assy.

### □ External View

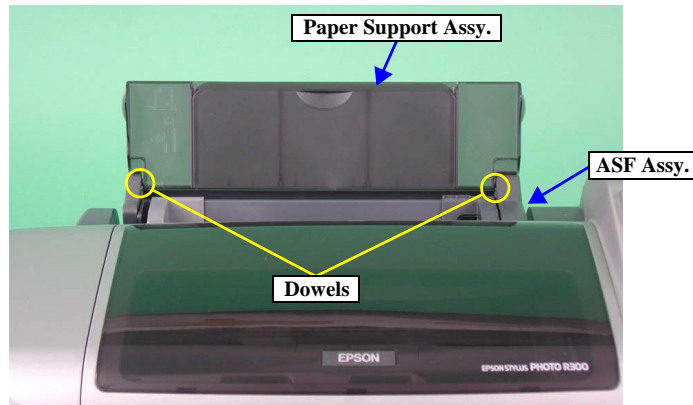

Figure 2-2. Removing "Paper Support Assy."

### □ Parts/Units which should be removed before removing "Paper Support Unit"

None

### □ Procedure for Removing

1. Release the dowels (x2) which secure "Paper Support Assy.". Then remove "Paper Support Assy." from "ASF Assy.".

## 2.3.2 Removing Housing, Upper

### □ External View

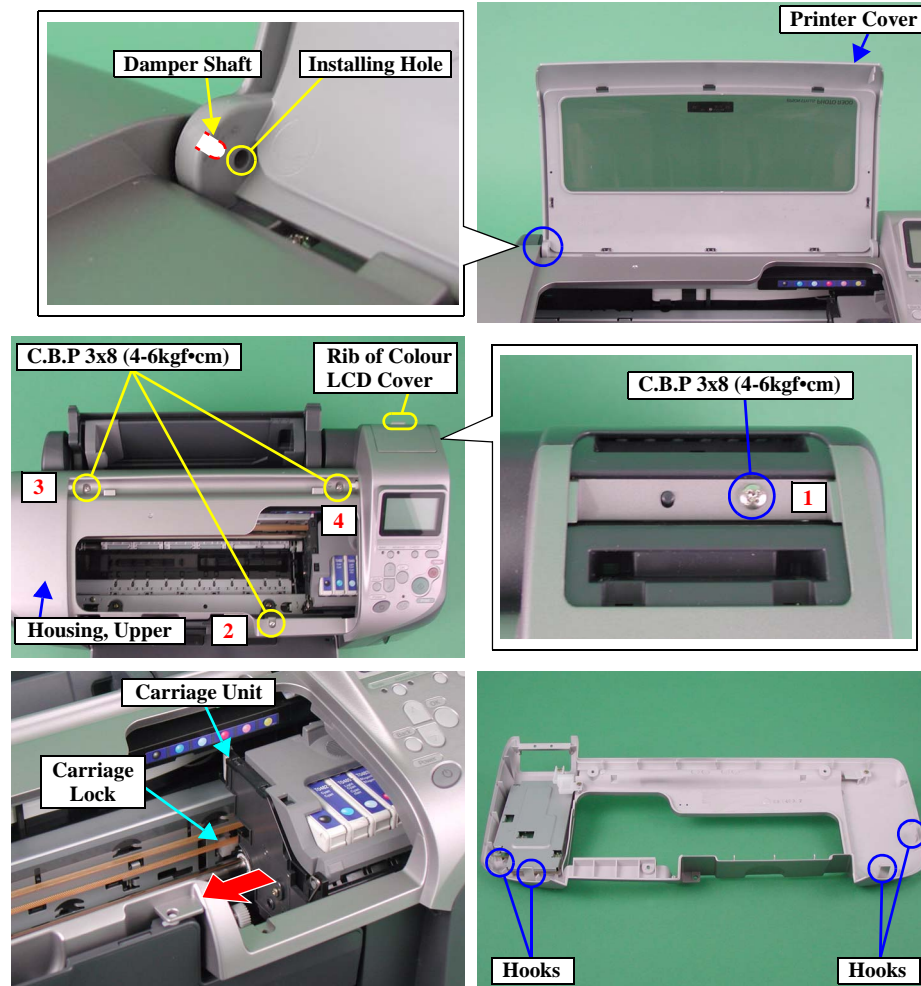

Figure 2-3. Removing "Housing, Upper" (1)

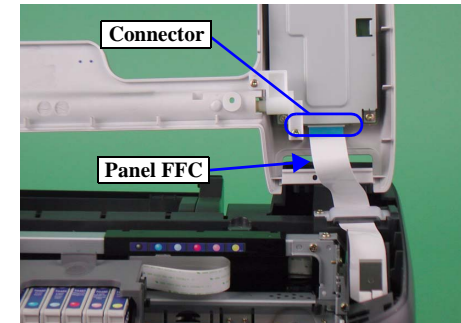

Figure 2-4. Removing "Housing, Upper" (2)

### □ Parts/Units which should be removed before removing "Housing, Upper"

Paper Support Assy.

### □ Procedure for Removing

1. Push the damper shaft by putting in the tweezers or alike into the installing hole of "Printer Cover". Then, remove "Printer Cover".
2. Push up the rib of "Colour LCD Cover" and then remove "Colour LCD Cover".
3. Remove the screws (x4) which secure "Housing, Upper".
4. Release "Carriage Lock" with the tweezers or alike and then move "Carriage Unit" toward the centre.
5. Release the hooks (x4) which secure "Housing, Upper" and then lift up "Housing, Upper".
6. Detach "Panel FFC" from the connector of "Panel Board" and then remove "Housing, Upper".



- Tighten the screws in the order as shown in the figure.
- Make sure to put the dowels (x2) of "Housing, Upper" into the attaching holes (x2) on "Printer Cover".

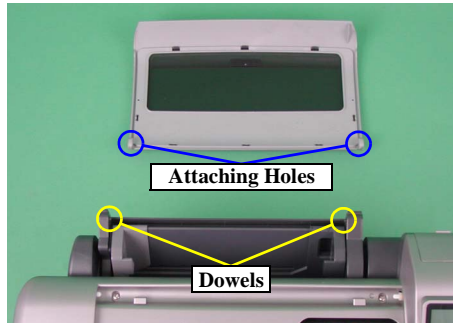

Figure 2-5. Reinstalling "Printer Cover"



## 2.3.3 Removing Housing, Middle

### □ External View

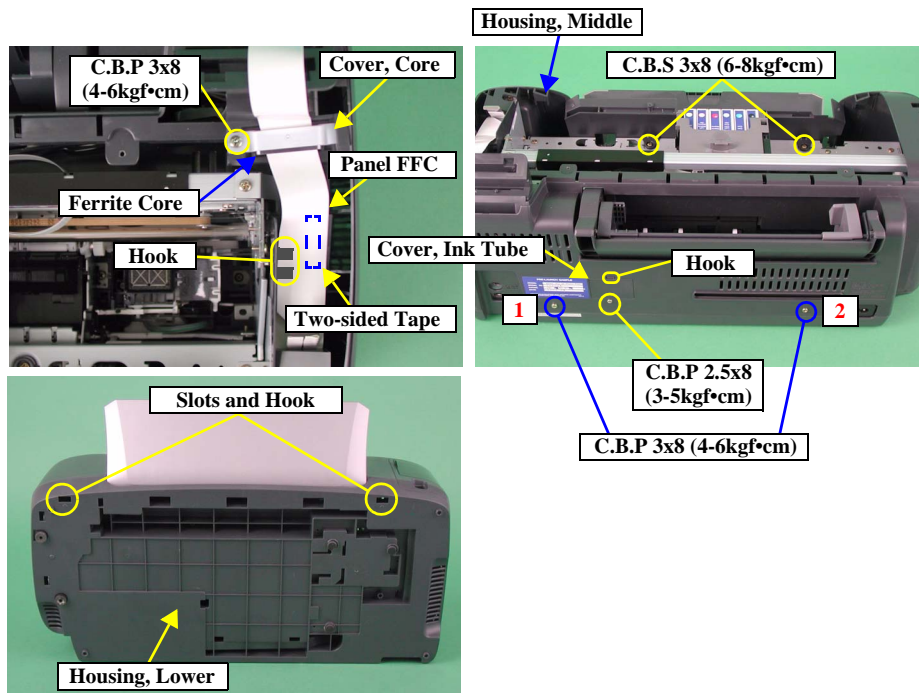

Figure 2-6. Removing "Housing, Middle"

- Parts/Units which should be removed before removing "Housing, Middle"  
Paper Support Assy./Housing, Upper

### □ Procedure for Removing

1. Remove the screw which secures "Cover, Core" and then remove "Cover, Core".
2. Pull out "Panel FFC" from "Ferrite Core".
3. Take off the two-sided tape which secures "Panel FFC" from "Housing, Middle". Then, release "Panel FFC" from the hooks (x2) of "Housing, Middle".
4. Remove the screw which secures "Cover, Ink Tube", release the hook and then remove "Cover, Ink Tube".
5. Remove the screws (x4) which secure "Housing, Middle".
6. Lay down the printer backward, put a flat-blade screwdriver or alike into the slot located on the bottom surface of "Housing, Lower" and then release the hooks (x2) which secure "Housing, Middle".



**Do not damage the hooks of "Housing, Middle" with the flat-blade screwdriver or alike.**

7. Lift "Housing, Middle" upward and remove it.



- When removing "Housing, Middle", the grounding spring may detach and drop from "Main Board Unit". If this occurs, reattach it to its original position referring to the following figure.

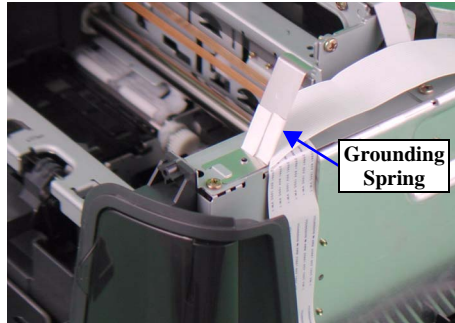

Figure 2-7. Reattaching the Ground Spring

- Make sure to mount "Panel FFC" passing under the hooks as shown in the figure and then secure "Panel FFC" with a two-sided tape.
- Make sure that "Panel FFC" is securely set and it is not reaching the upper edge of the rib of "Housing, Middle" as shown in the figure.

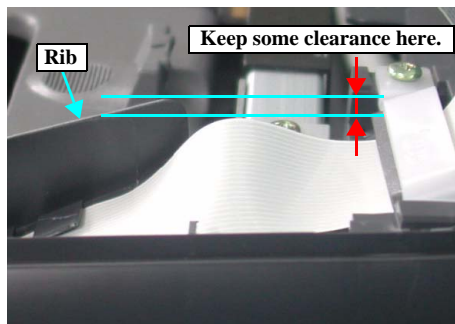

Figure 2-8. Mounting "Panel FFC"



- Make sure that the connector cable of "Power Supply Board" is securely set in the groove of "Housing, Lower".

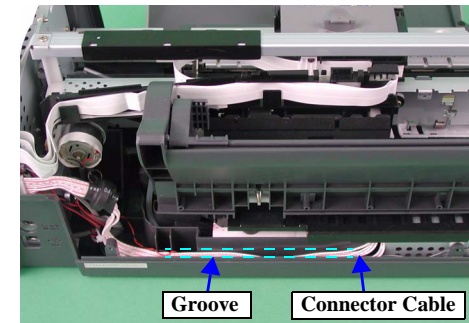

Figure 2-9. Mounting the Connector Cable

- Make sure that "Panel FFC" is not stuck under "Housing, Middle".
- Make sure to tighten up the screws on the back of "Housing, Middle" in the order as shown in the figure.

## 2.3.4 Removing Porous Pad, Paper Guide, Front

### □ External View

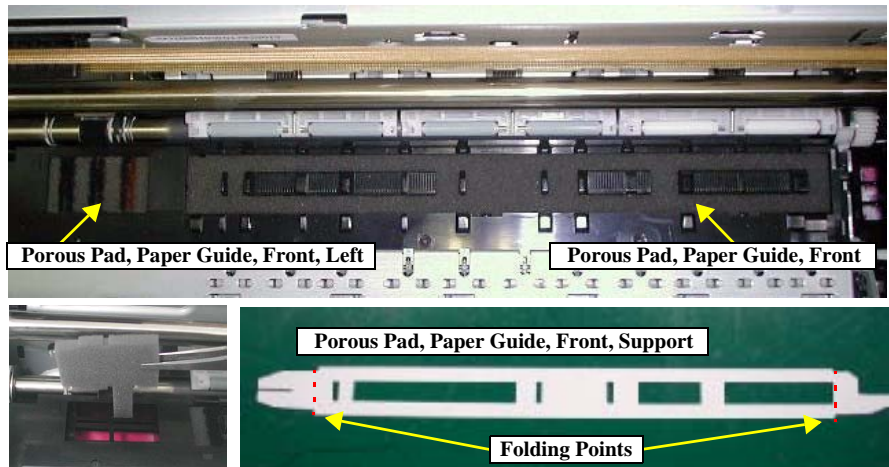

Figure 2-10. Removing "Porous Pad, Paper Guide, Front"

### □ Pars/Units which should be removed before removing "Porous Pad, Paper Guide, Front"

Paper Support Assy./Housing, Upper"/"Housing, Middle

### □ Procedure for Removing

1. Remove the following 3 types of porous pads from "Paper Guide, Front" using the tweezers.
  - Porous Pad, Paper Guide, Front
  - Porous Pad, Paper Guide, Front, Support
  - Porous Pad, Paper Guide, Front, Left

#### CAUTION



Make sure to take "Porous Pad, Paper Guide, Front" cleanly as it is glued.

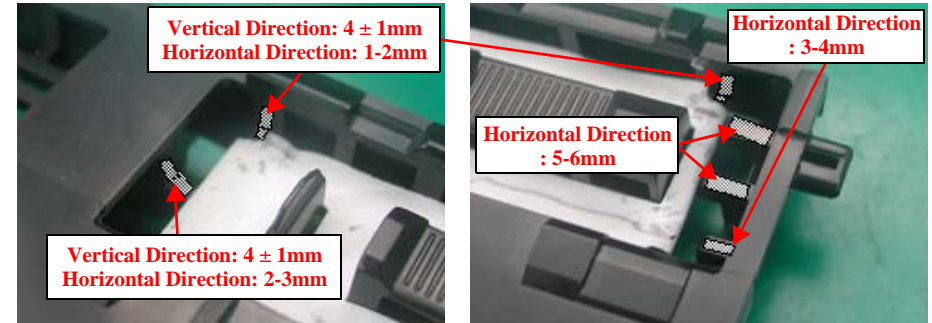

Figure 2-11. Gluing Point of "Porous Pad, Paper Guide, Front"



- ### □ Reinstalling "Porous Pad, Paper Guide, Front"/"Porous Pad, Paper Guide, Front, Support"
- Fold perpendicularly left and right sides of "Porous Pad, Paper Guide, Front, Support" at the marks and install it to "Paper Guide, Front". Make sure that the slit engages with the rib located on the side of "Paper Guide, Front" so that they will fit securely.
  - Apply ThreeBond 1401 to the 6 points shown in the figure above.
  - Install "Porous Pad, Paper Guide, Front" in piles. Put it under the rib, and check if it is securely fit. Adjust the clearance between "Porous Pad, Paper Guide, Front" and "Paper Guide, Front" approximately in 0.5 - 1.0mm.
- ### □ Reinstalling "Porous Pad, Paper Guide, Front, Support"
- Insert the foot-parts into the holes of "Paper Guide, Front". Then, put them under the rib and check if it is securely fit.
- ### □ Do not damage "Porous Pad, Paper Guide, Front, Support".
- ### □ Do not apply too much adhesive when using some. Do not contaminate "Porous Pad, Paper Guide, Front, Support" with the adhesive.
- ### □ Install "Porous Pad, Paper Guide, Front" immediately after applying the adhesive.
- ### □ Make sure that the 3 porous pads are fit securely.

#### CAUTION



## 2.3.5 Removing Panel Board

### □ External View

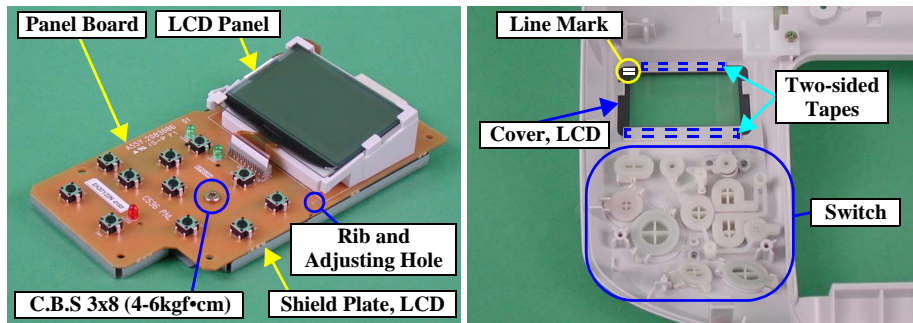
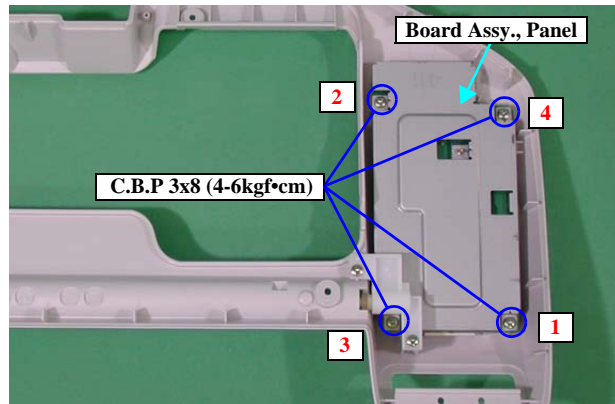

Figure 2-12. Removing "Panel Board"

### □ Parts/Units which should be removed before removing "Panel Board"

Paper Support Assy./Housing, Upper

### □ Procedure for Removing

1. Remove the screws (x4) which secure "Board Assy., Panel". Then, remove "Board Assy., Panel".
2. Remove the screw which secures "Panel Board". Then, remove "Panel Board" from "Shield Plate, LCD".
3. Take off the two-sided tapes (x2) which secure "Cover, LCD" from the back of "Housing, Upper". Then, remove "Cover, LCD".



Do not damage "LCD Panel".



- When removing "Panel Board Unit", the switch may detach and drop. If this occurs, reinstall it referring the figure.
- When looking at back side of "Housing, Upper", make sure that the line mark of "Housing, Upper" securely comes to the position shown in the figure.
- Match the rib of "Shield Plate, LCD" and the positioning hole of "Panel Board".
- Screw "Board Assy., Panel" in the order as shown in the figure.

## 2.3.6 Removing Stacker Assy.

### □ External View

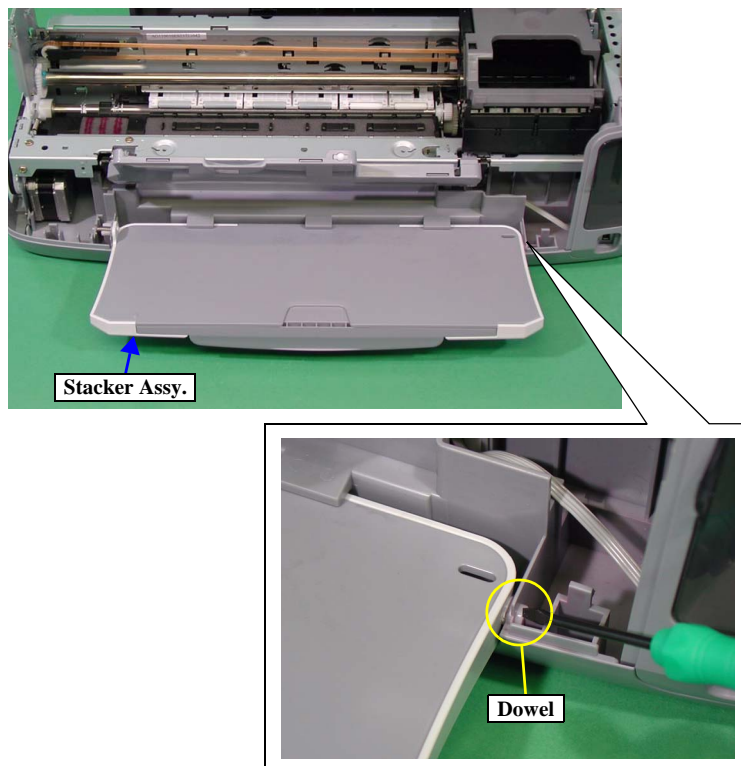

Figure 2-13. Removing "Stacker Assy."

### □ Parts/Units which should be removed before removing "Stacker Assy."

Paper Support Assy./Housing, Upper/Housing, Middle

### □ Procedure for Removing

1. Release the dowel which secures "Stacker Assy." by using a flat-blade screwdriver or alike. Then, remove "Stacker Assy.".



Match the dowels (x2) of "Stacker Assy." and the installing holes (x2) of "Housing, Lower".

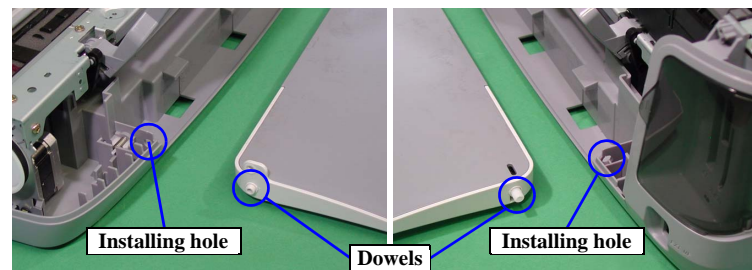

Figure 2-14. Reinstalling "Stacker Assy."

### 2.3.7 Removing Main Board

□ External View

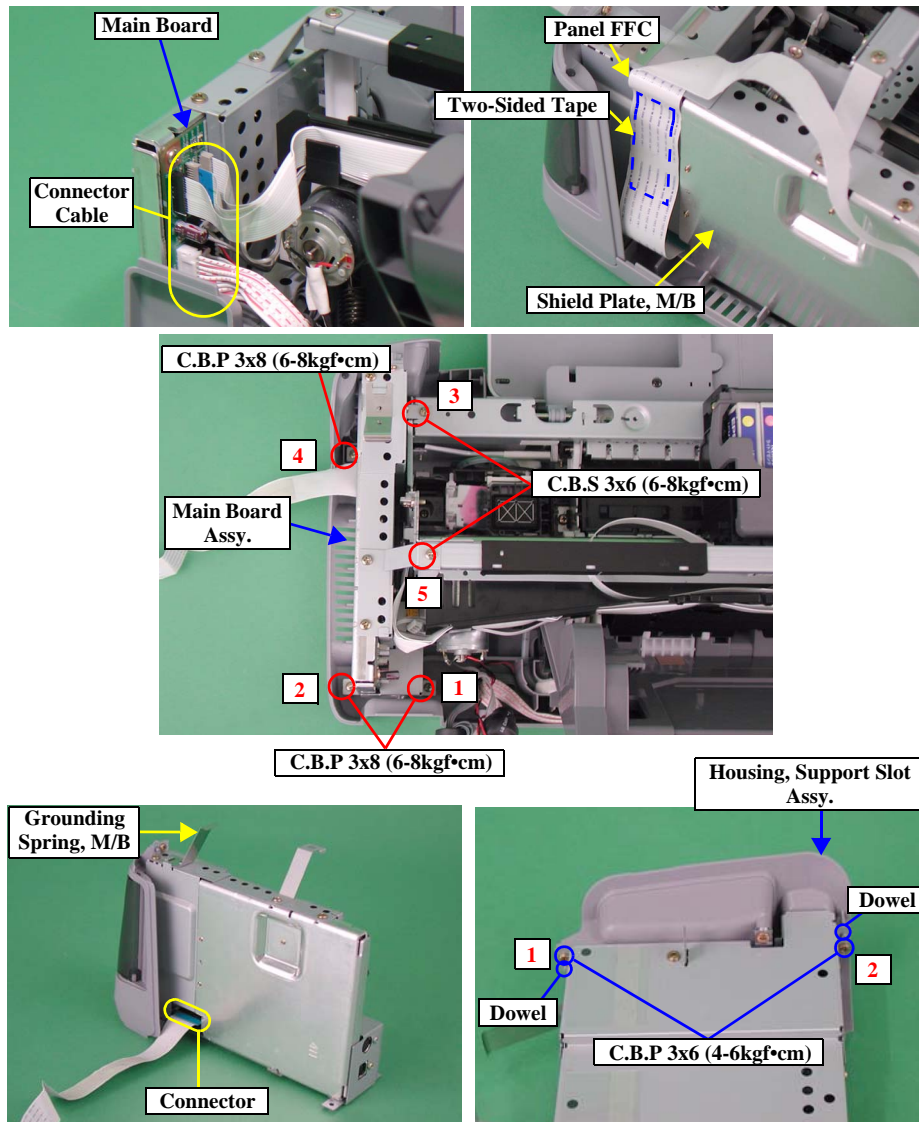

Figure 2-15. Removing "Main Board" (1)

- Parts/Units which should be removed before removing "Main Board"  
Paper Support Assy./Housing, Upper/Housing, Middle

□ Procedure for Removing

1. Disconnect all the connectors from "Main Board".

Table 2-3. Connectors connected to "C536 Main Board"

Connector No.	Colour	Number of Pins	Where to Connect
CN3	White	10	Power Supply Board
CN4	White	3	PE Sensor
CN5	Black	3	PG Sensor
CN6	Red	4	Star Wheel/CDR Sensor
CN7	White	2	PG Motor
CN8	Black	4	CR Motor
CN9	White	4	PF Motor
CN10	-	14	CSIC Board/CR Encoder Sensor/PW Sensor
CN11	-	15	Print Head
CN12	-	15	Print Head

2. Take off the two-sided tape which secures "Panel FFC" from "Shield Plate, M/B".
3. Remove the screws (x5) which secure "Main Board Assy.". Then, remove "Main Board Assy.".
4. Remove "Grounding Spring, M/B" from "Main Board Assy.".
5. Remove "Panel FFC" from the connector of "Main Board".
6. Remove the screws (x2) which secure "Housing, Support Slot Assy.". Then, remove "Housing, Support Slot Assy.".

External View

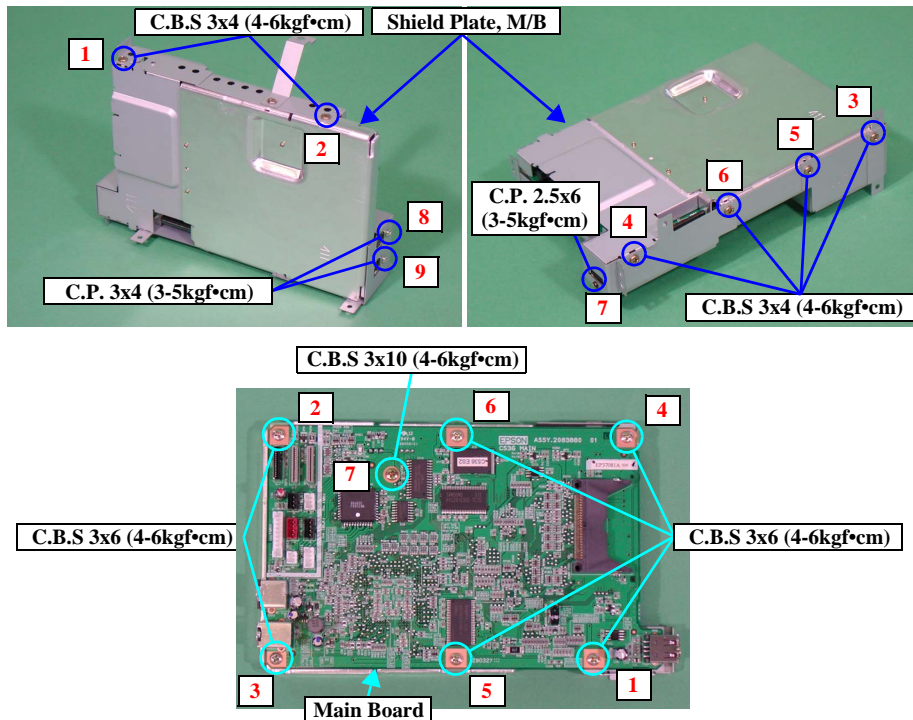

Figure 2-16. Removing "Main Board" (2)

7. Remove the screws (x9) which secure "Shield Plate, M/B". Then, remove "Shield Plate, M/B".
8. Remove the screws (x7) which secure "Main Board". Then, remove "Main Board".



- Reinstalling "Main Board"/"Shield Plate, M/B"
  - Screw in the order as shown in Figure 2-16.
- Reinstalling "Housing, Support Slot Assy."
  - Match the dowels (x2) of "Housing, Support Slot Assy." and the positioning holes of Shield Plate, M/B".
  - Screw in the order as shown in Figure 2-15.
- Reinstalling "Panel FFC"
  - Make sure to match "Panel FFC" and the lateral face of "Shield Plate, M/B" and then attach it to "Main Board Assy." with a two-sided tape.

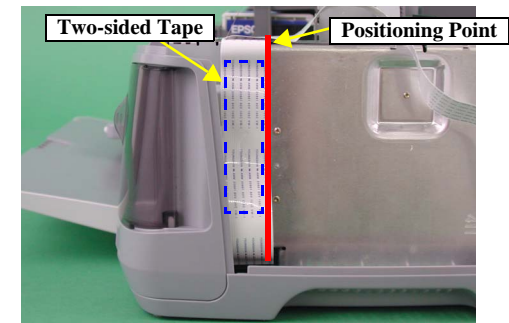

Figure 2-17. Mounting "Panel FFC"



- When having replaced "Main Board", implement the adjustment in the following order. (Refer to Chapter 3 "ADJUSTMENT")
  - When possible to read data from the old board
    1. EEPROM data copy
  - When impossible to read from the old board
    1. Replace "Waste Ink Pads" with new one.  
(To count the amount of the waste ink)
    2. Market Setting
    3. USB ID Input
    4. Waste Ink Pad Counter
    5. Head ID Input
    6. First Dot Adjustment
    7. PW Sensor Adjustment
    8. Head Angular Adjustment
    9. Bi-D Adjustment
    10. Offset Input for CR Motor Calorific Limitation



## 2.3.8 Removing ASF Assy.

### □ External View

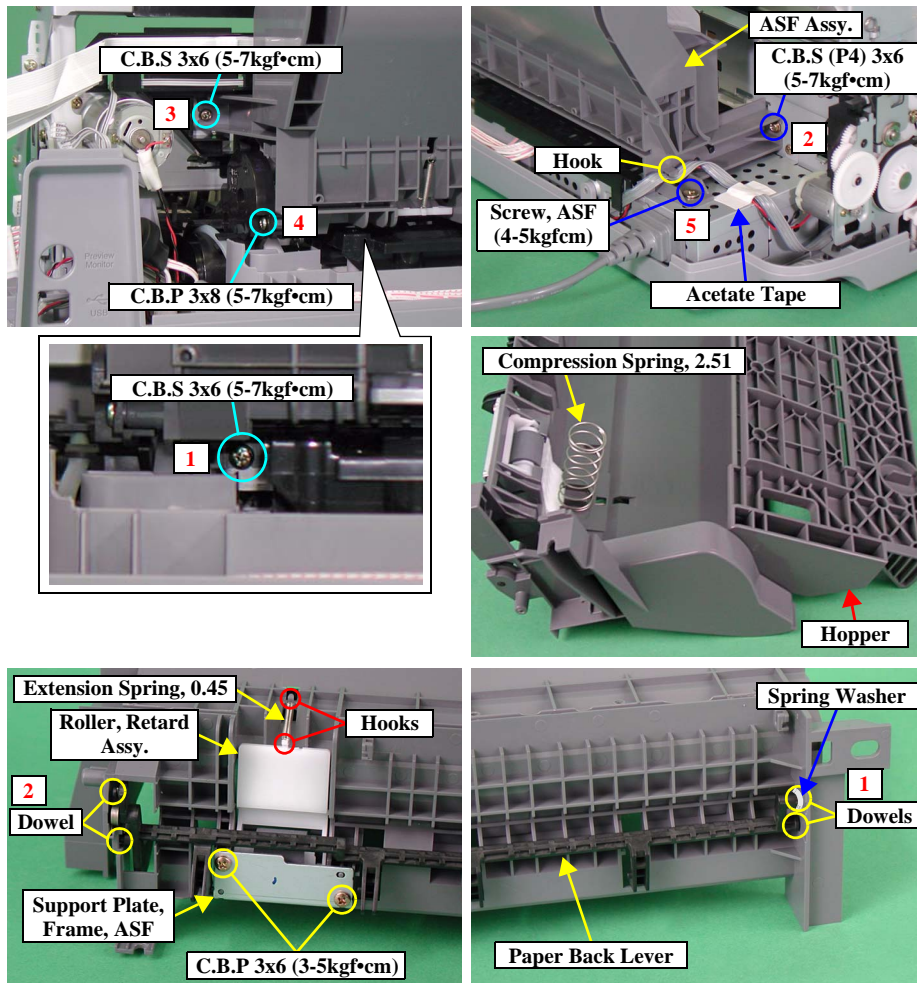

Figure 2-18. Removing "ASF Assy."

### □ Parts/Units which should be removed before removing "ASF Assy."

Paper Support Assy./Housing, Upper/Housing, Middle/Main Board Unit

### □ Procedure for Removing

1. Take off the acetate tape. Then, release the connector cables of "PF Motor" and "PG Motor" from the hook of "ASF Assy."
2. Remove the screws (x5) which secure "ASF Assy.". Then, remove "ASF Assy." for the back of the printer.
3. Open "Hopper" and then remove "Compression Spring, 2.51".
4. Bow slightly down "Paper Back Lever" and release the dowels (x2) on the both sides in the order of [1], [2]. Then, remove "Paper Back Lever".



**CAUTION** When removing "Paper Back Lever", the spring washer will detach and drop. Take care not to lose it.

5. Remove the screws (x2) which secure "Support Plate, Frame, ASF".
6. Release the hooks (x2) which secure "Extension Spring, 0.45". Then, remove "Roller, Retard Assy."



- When reassembling "ASF Assy."
  - Make sure that "Extension Spring, 0.45" is hooked on "Frame, ASF" and "Roller, Retard Assy."
  - Check if "Torsion Spring, 6.45" is correctly installed on "Paper Back Lever" and "Frame, ASF".

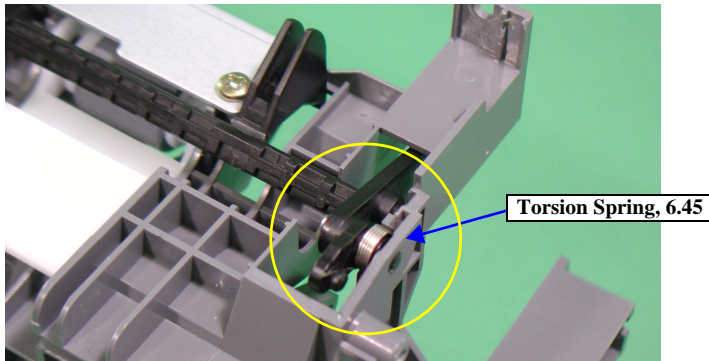

Figure 2-19. Removing "Torsion Spring, 6.45"

- Check if "Paper Back Lever" and "Roller, Retard Assy." move smoothly.
- Do not touch the cork of "Hopper".



- Reinstalling "ASF Assy."
  - Install "Compression Spring, 2.51" on "Hopper", then check if "Hopper" moves smoothly.
  - Screw in the order as shown in the figure.
  - Make sure that there is no gap between "ASF Assy." and "Frame, Main".



- When having replaced "ASF Assy.", apply G-46 grease to the specified points in adequate dose. (Refer to Chapter 4 "MAINTENANCE")
- When having replaced or removed "ASF Assy.", implement the adjustment in the following order. (Refer to Chapter 3 "ADJUSTMENT")
  1. First Dot Adjustment

## 2.3.9 Removing Holder, Shaft Assy.

### □ External View

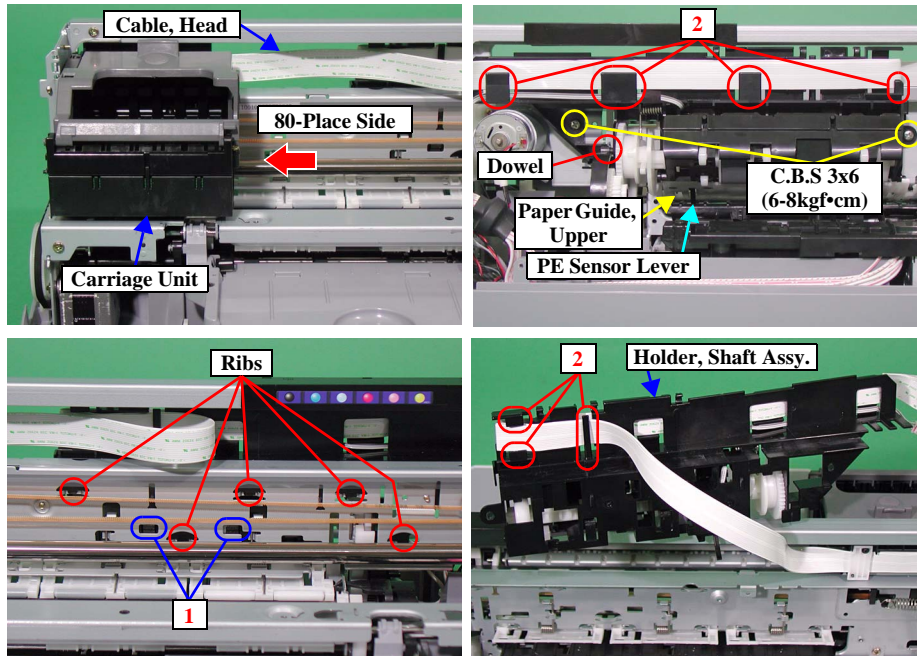

Figure 2-20. Removing "Holder, Shaft Assy." (1)

### □ Parts/Units which should be removed before removing "Holder, Shaft Assy."

Paper Support Assy./Housing, Upper/Housing, Middle/Main Board Unit/ASF Assy.

### □ Procedure for Removing

1. Move "Carriage Unit" toward 80-Place Side.
2. Remove the screws (x2) which secure "Holder, Shaft Assy.".
3. Pull "Holder, Shaft Assy." upward and release the hooks (1): x2) with the tweezers or alike. Then, Release the dowel from "Ink System Frame".
4. Looking at the printer from its back side, press down "Paper Guide, Upper" on the left, and release "PE Sensor Lever" from the slot. Remove "Holder, Shaft Assy." by sliding it to the right.

#### CAUTION



Be careful not to damage "PE Sensor Lever" and "Paper Guide, Upper" when removing them since "PE Sensor Lever" contacts with "Paper Guide, Upper".

5. Release "Cable, Head" from the hooks (2): x7) of "Holder, Shaft Assy.".

#### CAUTION



Do not damage "Cable, Head".

□ External View

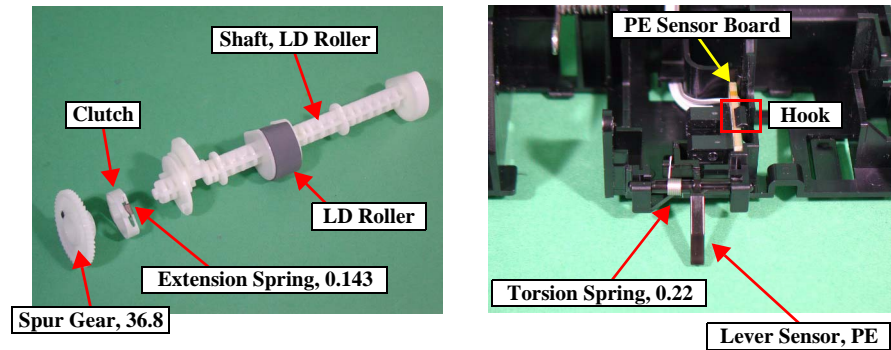
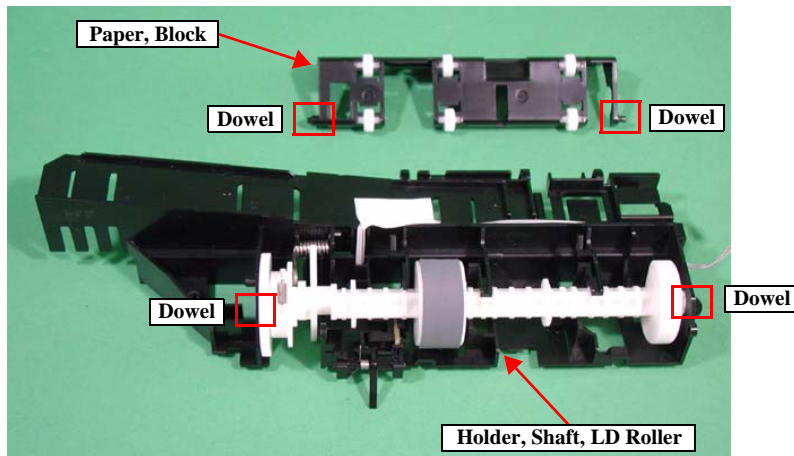

Figure 2-21. Removing "Holder, Shaft Assy." (2)

■ Removing "LD Roller"

1. Release the dowels (x2) which secure "Paper, Block". Then, remove "Paper, Block".
2. Release the dowels (x2) which secure "Shaft, LD Roller". Then, remove "Shaft, LD Roller" and "Clutch" together from "Holder, Shaft, LD Roller".
3. Remove "LD Roller" from "Shaft, LD Roller".



Do not touch "LD Roller" with bare hands.



□ Reinstalling "LD Roller"

- Make sure to match the direction (△ Mark) indicated on "Shaft, LD Roller" and the direction (△ Mark) indicated on the back side of "LD Roller".

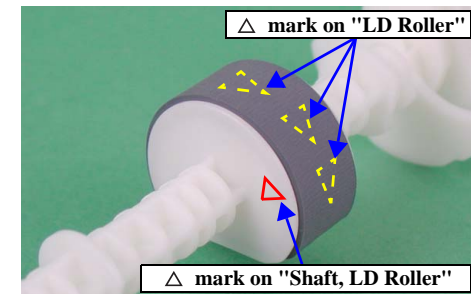

Figure 2-22. Position of "Torsion Spring, 137.7"



- Reinstalling "Clutch"
  - Make sure that the dowel of "Shaft, LD Roller" is fitted in the installing hole of "Clutch".
  - Make sure that "Extension Spring, 0.143" is securely set on the hooks of "Clutch" and "Shaft, LD Roller".
  - Do not set "Extension Spring, 0.143" in twisted form.
  - Make sure that "Clutch" rotates correctly.
- Reinstalling "Shaft, LD Roller"
  - Do not touch "LD Roller".
  - Check if the straight part of "Torsion Spring, 137.7" is set between the 2 cams of "Shaft, LD Roller".

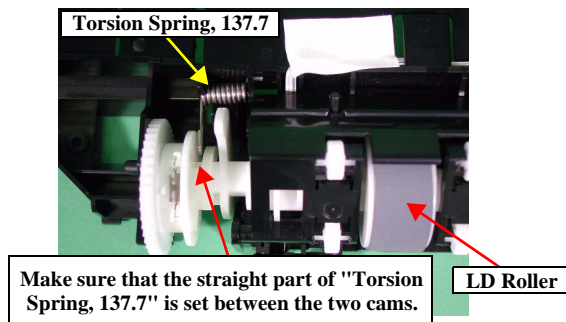

Figure 2-23. Position of "Torsion Spring, 137.7"



- Reinstalling "Holder, Shaft Assy."
  - Check if the hooks (x2), the dowel and the ribs (x5) of "Holder, Shaft Assy." are correctly secured.
  - Check if the connector cable of "PE Sensor" and "Cable, Head" are installed at the correct position of "Holder, Shaft Assy.".
  - Do not touch "LD Roller".
  - Do not damage the teeth of "Spur Gear, 36.8" and "Combination Gear, 27.2, 19.2".

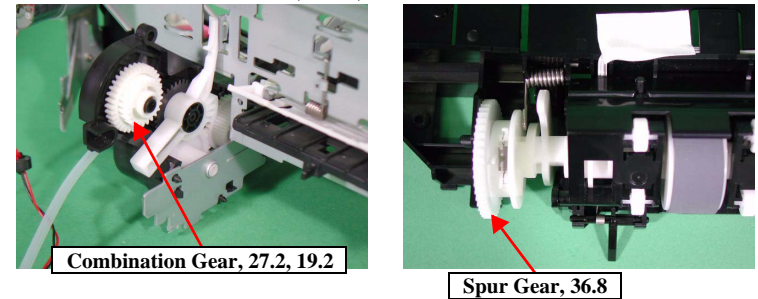

Figure 2-24. "Spur Gear, 36.8" and "Combination Gear, 27.2, 19.2"



- When having replaced "Shaft, LD Roller", apply G-46 grease to the specified points in adequate dose. (Refer to Chapter 4 "MAINTENANCE")
- When having replaced or removed "Holder, Shaft Assy.", implement the following adjustment. (Refer to Chapter 3 "ADJUSTMENT")
  - First Dot Adjustment

## 2.3.10 Removing CR Motor

### □ External View

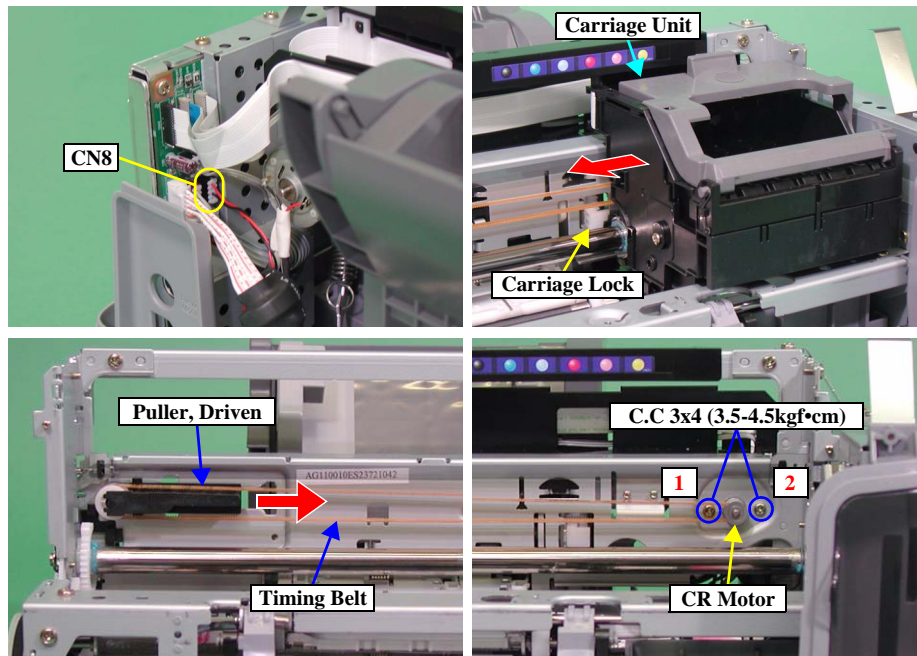

Figure 2-25. Removing "CR Motor"

### □ Parts/Units which should be removed before removing "CR Motor"

Paper Support Assy./Housing, Upper/Housing, Middle

### □ Procedure for Removing

1. Disconnect the connector cable of "CR Motor" from the connector (CN8) of "Main Board".
2. Release the carriage lock with the tweezers or alike, then move "Carriage Unit" to the centre of the printer.
3. Push "Pulley, Driven" in the direction of the arrow and loosen the tension of "Timing Belt". Then, remove "Timing Belt" from the pinion gear of "CR Motor".
4. Remove the screws (x2) which secure "CR Motor". Then, remove "CR Motor".



**Do not damage the pinion gear when removing "CR Motor".**



- Make sure to screw "CR Motor" in the order as shown in the figure.
- Make sure that there is no gap between "CR Motor" and "Frame, Main".
- Make sure that the part on which "CR Motor" Lot number is printed is face-up.



- When having removed or replaced "CR Motor", implement the adjustment in the following order. (Refer to Chapter 3 "ADJUSTMENT")
  1. First dot Adjustment
  2. PW Sensor Adjustment
  3. Head Angular Adjustment
  4. Bi-D Adjustment
  5. Offset Input for CR Motor Calorific Limitation (When Replaced)

### 2.3.11 Removing APG Assy.

#### □ External View

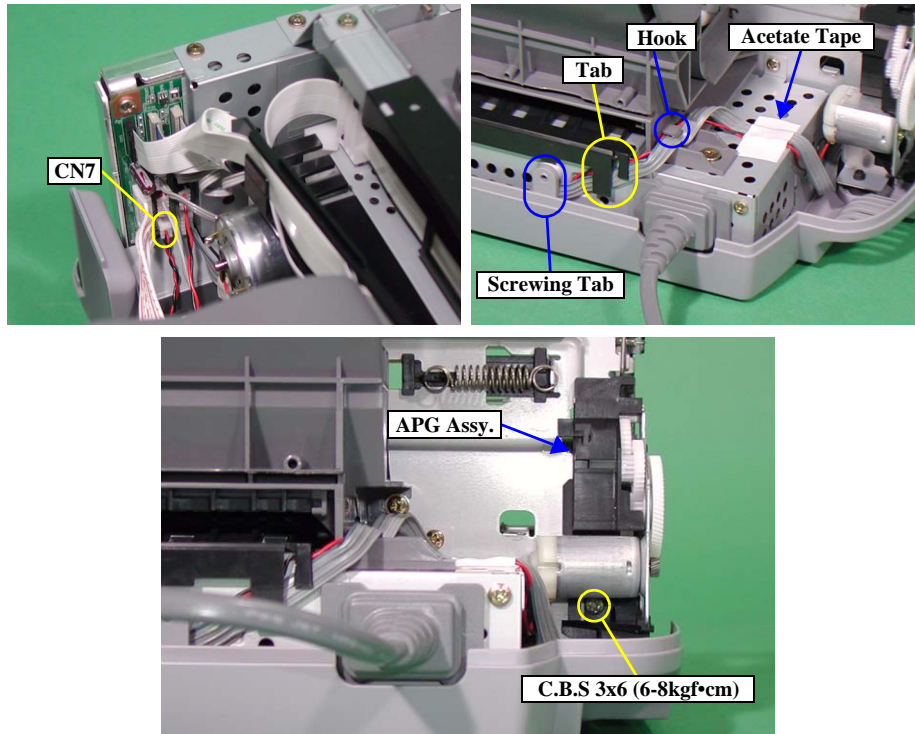

Figure 2-26. Removing "APG Assy."

#### □ Parts/Units which should be removed before removing "APG Assy."

Paper Support Assy./Housing, Upper/Housing, Middle

#### □ Procedure for Removing

1. Disconnect the connector cable of "PG Motor" from CN7 of "Main Board".
2. Release the connector cables of "PF Motor" and "PG Motor" from the following points.
  - Acetate tape
  - Hook of "ASF Assy."
  - Tab of "Paper Guide, CDR" (x2)
  - Screwing tab of "Housing, Lower"
3. Remove the screw which secures "APG Assy.". Then, remove "APG Assy."



- Make sure that the hooks (x2) and the dowels (x2) of "APG Assy." are securely attached to "Frame, Main".
- Check if the part indicated in the following figure is inserted in the slits of "Frame, Main".

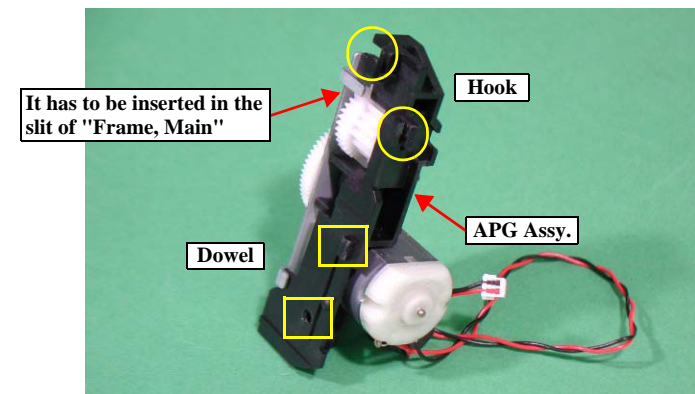

Figure 2-27. Reinstalling "APG Assy."

## 2.3.12 Removing Print Head

### □ External View

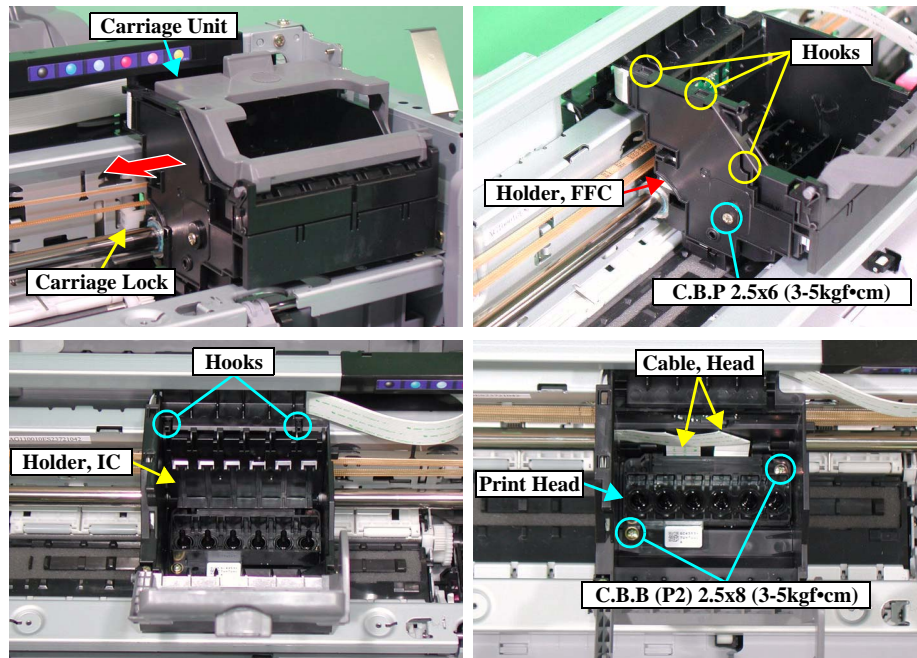

Figure 2-28. Removing "Print Head"

### □ Parts/Units which should be removed before removing "Print Head".

Paper Support Assy./Housing, Upper/Housing, Middle

### □ Procedure for Removing

1. Remove all the ink cartridges from "Carriage Unit".
2. Release "Carriage Lock" with the tweezers or alike, then move "Carriage Unit" to the centre of the printer.
3. Remove the screw (x1) which secures "Holder, FFC" with the No. 1 driver.
4. Slightly inflect the lower part of "Holder, FFC", release the hooks (x3) by sliding it downward. Then, remove "Holder, FFC".
5. Release the hooks (x2) which secure "Holder, IC", and remove "Holder, IC" upward.

6. Remove the screws (x2) which secure "Print Head" with Phillips screwdriver (No.1).
7. Disconnect "Cable, Head" from the connector of "Print Head" while slightly lifting "Print Head". Then, remove "Print Head".



Do not touch and/or damage the nozzle surface of "Print Head" when handling it.



- Check if "Head FFC" is correctly connected to the connector of "Print Head".
- Check if "Print Head" is correctly set to "Carriage Unit".



- When having removed or replaced "Print Head", implement the adjustment in the following order. (Refer to Chapter 3 "ADJUSTMENT")
  1. Ink Charge (When Replaced)
  2. Head ID Input (When Replaced)
  3. PG Adjustment
  4. First Dot Adjustment
  5. PW Sensor Adjustment
  6. Head Angular Adjustment
  7. Bi-D Adjustment



### 2.3.13 Removing Carriage Unit

#### □ External View

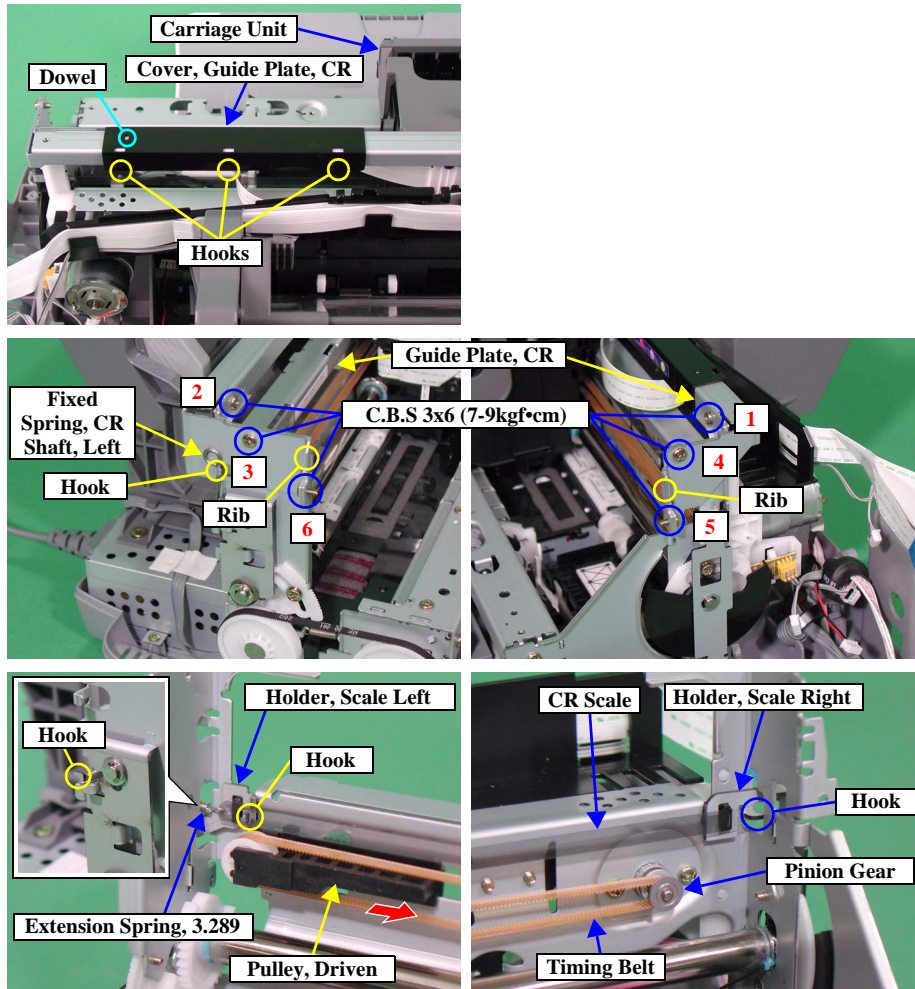

Figure 2-29. Removing "Carriage Unit" (1)

#### □ Parts/Units which should be removed before removing "Carriage Unit"

Paper Support Assy./Housing, Upper/Housing, Middle/Main Board Unit/  
APG Assy./Print Head

#### □ Procedure for Removing

1. Release the hooks (x3) which secure "Cover, Guide Plate, CR", then remove "Cover, Guide Plate, CR".
2. Remove "Fixed Spring, CR Shaft, Left" by releasing it from the hook of "Frame, Main".
3. Remove the screws (x6) which secure "Guide Plate, CR".
4. Release the ribs (x2) which secure "Guide Plate, CR". Then, remove "Guide Plate, CR" while stepping aside the hook which has secured "Fixed Spring, CR Shaft, Left".
5. Remove the right side of "CR Scale" from "Holder, Scale Right".
6. Pull out "CR Scale" from the back of "Carriage Unit" to the left. Then, release "CR Scale" from one of two hooks of "Holder, Scale, Left" first, and next release "Extension Spring, 3.289" from the other hook.
7. Remove "Extension Spring, 3.289" from "CR Scale".
8. Loosen the tension of "Timing Belt" by pushing "Pulley, Driven" to the right. Then, remove "Timing Belt" from the pinion gear of "CR Motor" first, and then from "Pulley, Driven".

□ External View

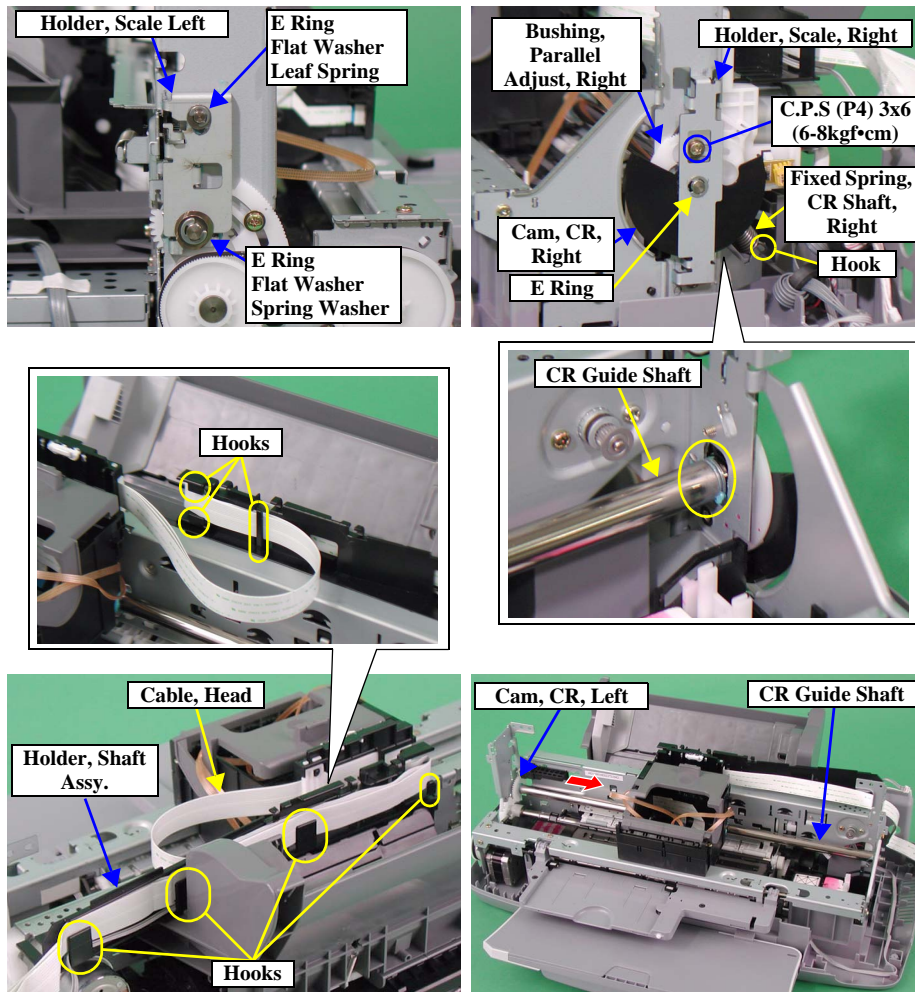

Figure 2-30. Removing "Carriage Unit" (2)

9. Remove the E ring, "Holder, Scale Right" and "Cam, CR, Right" from the right side of "CR Guide Shaft".
10. Remove the screw which secures "Bushing, Parallel Adjust, Right", Then, remove "Bushing, Parallel Adjust, Right".
11. Remove "Fixed Spring, CR Shaft, Right" from the hook of "Frame, Main". Remove "Fixed Spring, CR Shaft, Right" from "CR Guide Shaft".
12. Remove the E ring, the flat washer and the leaf spring which secure "Holder, Scale, Left".
13. Remove the E ring, the flat washer and the spring washer from the left side of "CR Guide Shaft". Then, remove "Holder, Scale, Left"
14. Release "Cable, Head" from the hooks (x7) of "Holder, Shaft Assy.".
15. Slide "CR Guide Shaft" to the right and pull it out from "Cam, CR, left". Then, remove "Carriage Unit" and "CR Guide Shaft" together.
16. Pull out "CR Guide Shaft" from "Carriage Unit".

□ External View

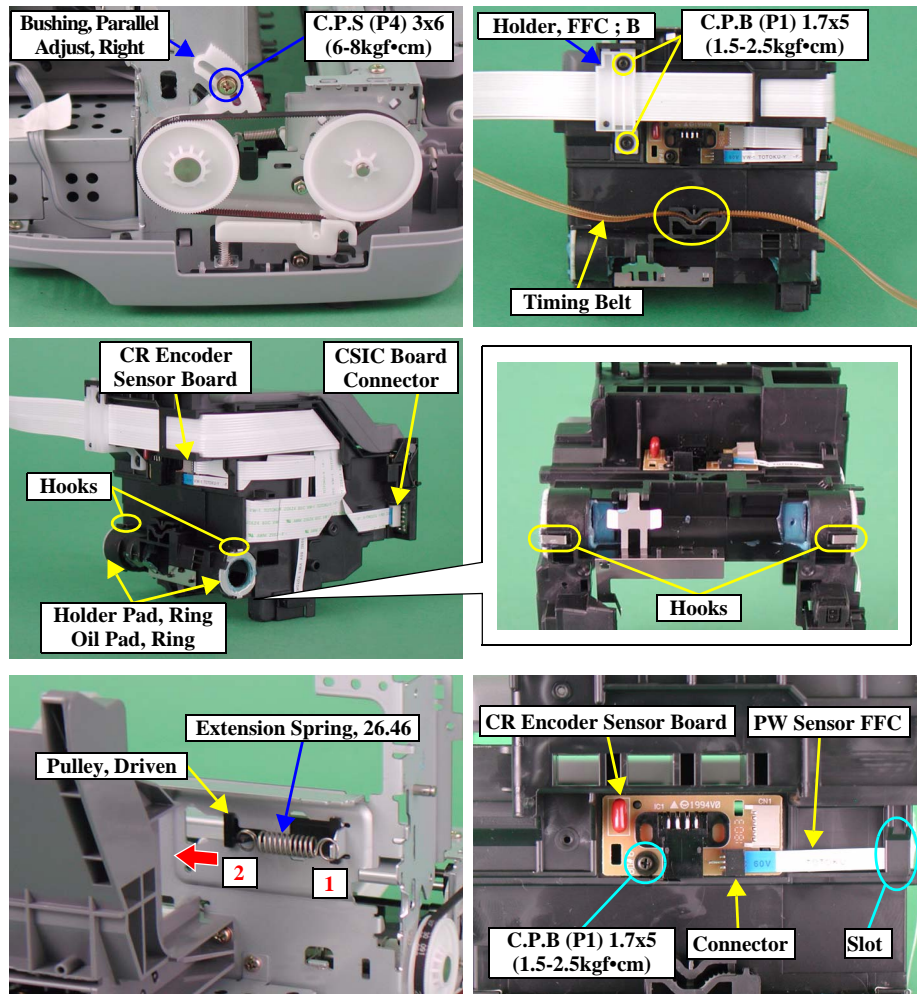

Figure 2-31. Removing "Carriage Unit" (3)

17. Remove the screw which secures "Bushing, Parallel Adjust, Left". Then, remove "Bushing, Parallel Adjust, Left".
18. Remove "Timing Belt" from "Carriage Unit".
19. Remove the screws which secure "Holder, FFC; B". Then, remove "Holder, FFC; B".
20. Remove "Cable, Head" from the connectors of "CSIC Board" and "CR Encoder Sensor Board". Then, remove "Cable Head" from "Carriage Unit".
21. Release the hooks (x2) from "Holder Pad, Ring" (x2). Then, remove "Holder Pad, Ring" (x2) and "Oil Pad, Ring" (x2).

■ Removing "Pulley, Driven"

1. Remove "Extension Spring, 26.46" from "Pulley Driven" and the hook of "Frame, Main" by using a flat-blade screwdriver. Then, remove "Extension Spring, 26.46".
2. Slide "Pulley, Driven" in the direction of the arrow. Then, remove "Frame, Main" from the slot.

■ Removing "CR Encoder Sensor Board"

1. Remove the screw which secures "CR Encoder Sensor Board" with Phillips screwdriver (No.0). Disconnect "PW Sensor FFC" from the connector of "CR Encoder Sensor Board". Then, remove "CR Encoder Sensor Board".

## External View

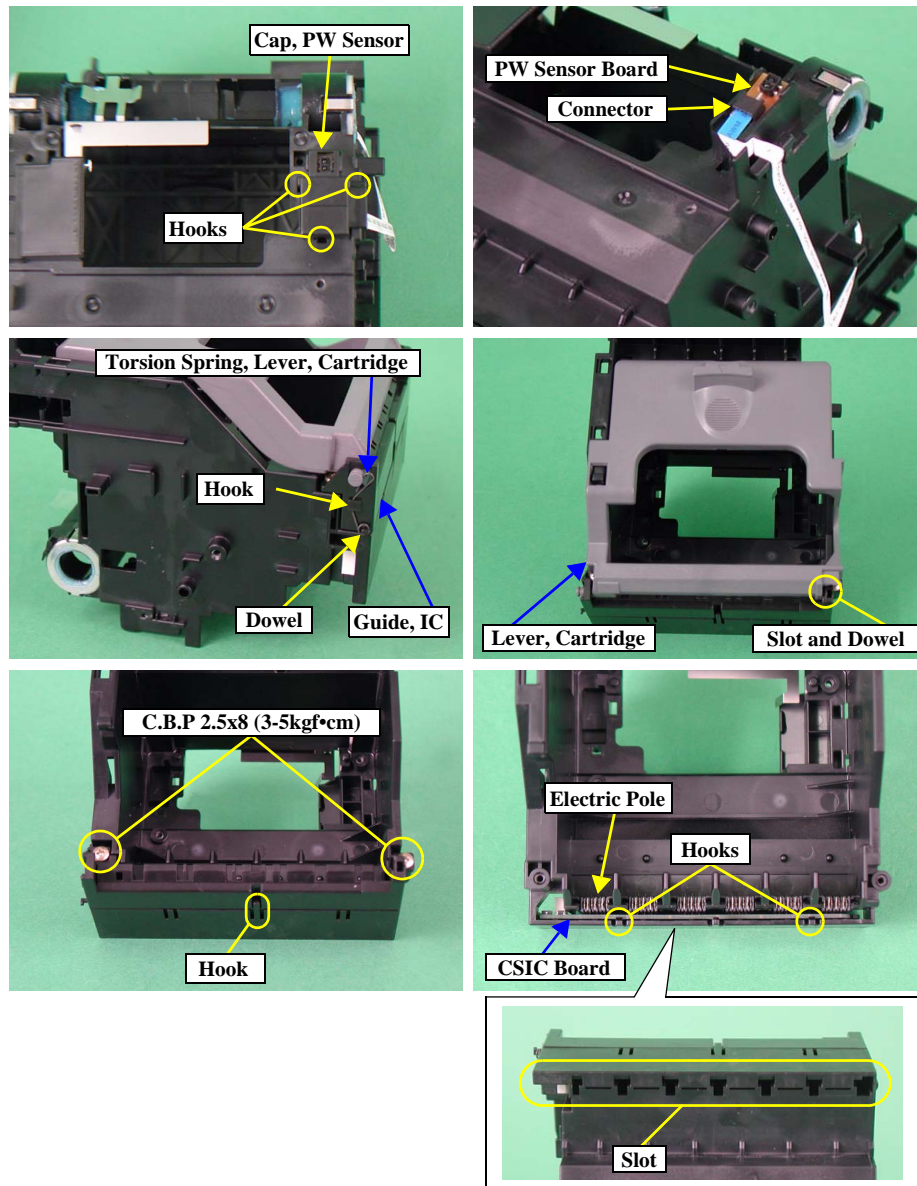

Figure 2-32. Removing "CR Unit" (4)

## Removing "PW Sensor Board"

1. Release the hooks (x3) which secure "Cap, PW Sensor". Then, remove "Cap, PW Sensor".

### CAUTION



When removing "Cap, PW Sensor", "PW Sensor Board" will be free. Therefore, take care not to damage "PW Sensor Board".

2. Pull out "PW Sensor Board" from the slot of "Carriage Unit". Then, remove "PW Sensor FFC" from the connector of "PW Sensor Board" and remove "PW Sensor Board" and "PW Sensor FFC".

## Removing "CSIC Board"

1. Remove "Torsion Spring, Lever, Cartridge" from the hook and the dowel of "Guide, IC".
2. Remove the dowel of "Lever, Cartridge" from the slot on the right side of "Guide, IC" by using the tweezers. Then, remove "Lever, Cartridge".
3. Remove the screws (x2) which secure "Guide, IC", then release the hook with the tweezers. And remove "Guide, IC".
4. Release the hooks (x2) which secure "CSIC Board", then push up "CSIC Board" from the slot located on the bottom of "Carriage Unit" with a flat-blade screwdriver or alike. Finally, remove "CSIC Board".

### CAUTION



Do not damage the electric pole with the flat-blade screwdriver or alike when removing "CSIC Board".



- Reinstalling "CSIC Board"
  - Check if "CSIC Board" is secured correctly.
- Reinstalling "PW Sensor Board"
  - Check if "PW Sensor FFC" is correctly connected.
  - Check if "PW Sensor Board" is correctly secured with "Cap, PW Sensor".
- Reinstalling "CR Encoder Sensor Board"
  - Check if "CR Encoder Sensor Board" is correctly secured.
  - Check if "CR Encoder Sensor Board" is correctly connected.
- Reinstalling "Holder, Scale, Right (Left)"
  - Check if "Slider, Holder, Scale" is set.

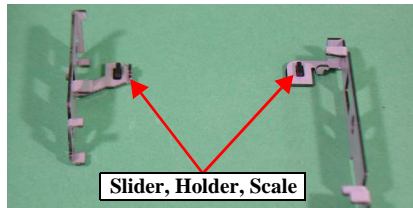

Figure 2-33. Reinstalling "Slider, Holder, Scale"



- Reinstalling "Carriage Unit"
  - Check if "Timing Belt" is correctly set to the installing groove of "Carriage Unit".
  - Check if "Grounding Plate, Head" is installed to the proper position of "Carriage Unit".

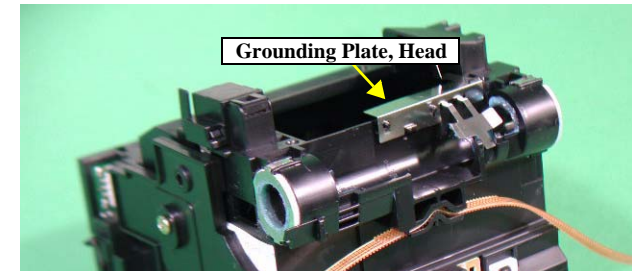

Figure 2-34. Installing Position of "Grounding Plate, Head"

- Reinstalling "CR Scale"
  - Make sure that "Extension Spring, 3.289" is not twisted.
  - Make sure to pass "CR Scale" through the slit of "CR Encoder Sensor".
  - Make sure to install "CR Scale" the cut-part on the left edge up.



Figure 2-35. Reinstalling "CR Scale"

- Reinstalling "Guide, CR"
  - Screw in the order as shown in the figure.



Do not adhere the grease at the contact point of 'Carriage' and "CR Lock Lever". Otherwise, fatal error may possible occur because 'CR Lock Lever' is not moved.



- When replacing the following parts or components with new ones, apply specified grease in its adequate dose. (Refer to Chapter 4 "MAINTENANCE")
  - Cam, CR, Right/Left
  - CR Guide Shaft
  - Holder, Scale, Right/Left
  - Pulley, Driven Assy.
- When having removed or replaced "Carriage Unit" or "CR Guide Shaft", implement the adjustment in the following order. (Refer to Chapter 3 "ADJUSTMENT")
  1. PG Adjustment
  2. First Dot Adjustment
  3. PW Sensor Adjustment
  4. Head Angular Adjustment (Only "Carriage Unit")
  5. Bi-D Adjustment
  6. Offset Input for CR Motor Calorific Limitation (When Replace "CR Guide SHaft")
- When having removed or replaced "PW Sensor", implement the adjustment in the following order. (Refer to Chapter 3 "ADJUSTMENT")
  1. PW Sensor Adjustment

## 2.3.14 Removing Paper Guide, Upper

### □ External View

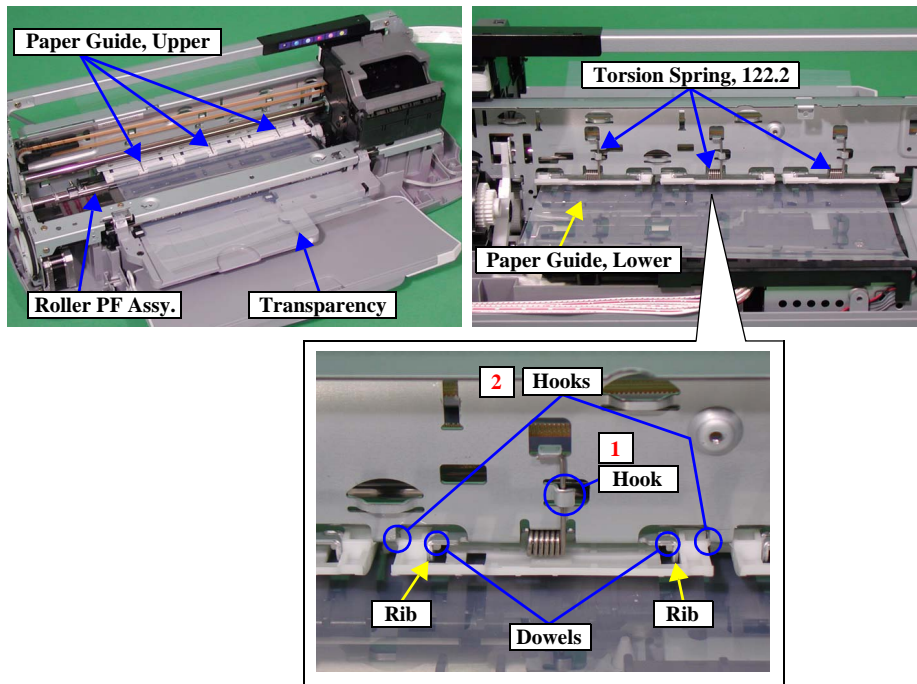

Figure 2-36. Removing "Paper Guide, Upper"

### □ Parts/Units which should be removed before removing "Paper Guide, Upper"

Paper Support Assy./Housing, Upper/Housing, Middle/Main Board Unit/ASF Assy./Holder, Shaft Assy.

### □ Procedure for Removing

1. Move "Carriage Unit" to the home position.
2. Put a transparency between "Paper Guide, Upper" and "Roller PF Assy.".
3. Release "Torsion Spring, 122.2" (x3) from the hook (1): 1 each) of "Frame, Main", then pull it out to the front.
4. Release the hooks (2): 2 each) which secure "Paper Guide, Upper" (x3) to upward. Then, release the dowels (2 each) while slightly holding up "Paper Guide, Upper".
5. Press down "Paper Guide, Lower" and pull out "Paper Guide, Upper" (x3) to the front while stepping it aside the ribs (2 each) of "Frame, Main"



- There are 2 types of "Driven Rollers" of "Paper Guide, Upper". Install them as shown in the following figure.

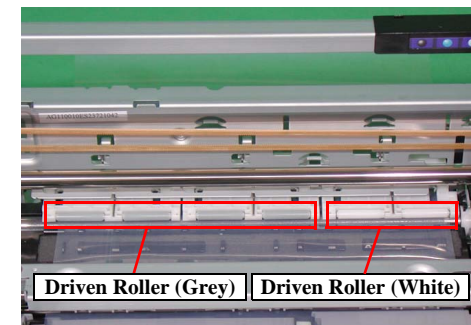

Figure 2-37. Installing Position of "Paper Guide, Upper"

## 2.3.15 Removing Printer Mechanism/ Housing, Lower

### □ External View

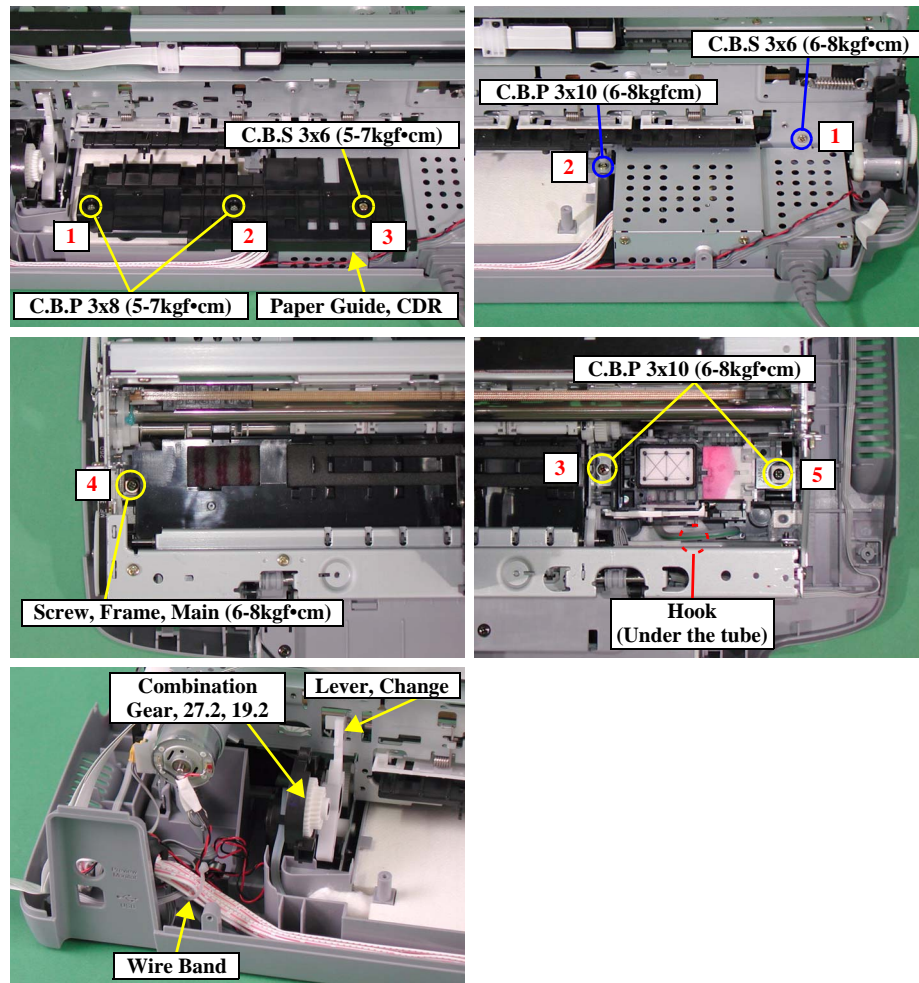

Figure 2-38. Removing "Printer Mechanism"/"Housing, Lower" (1)

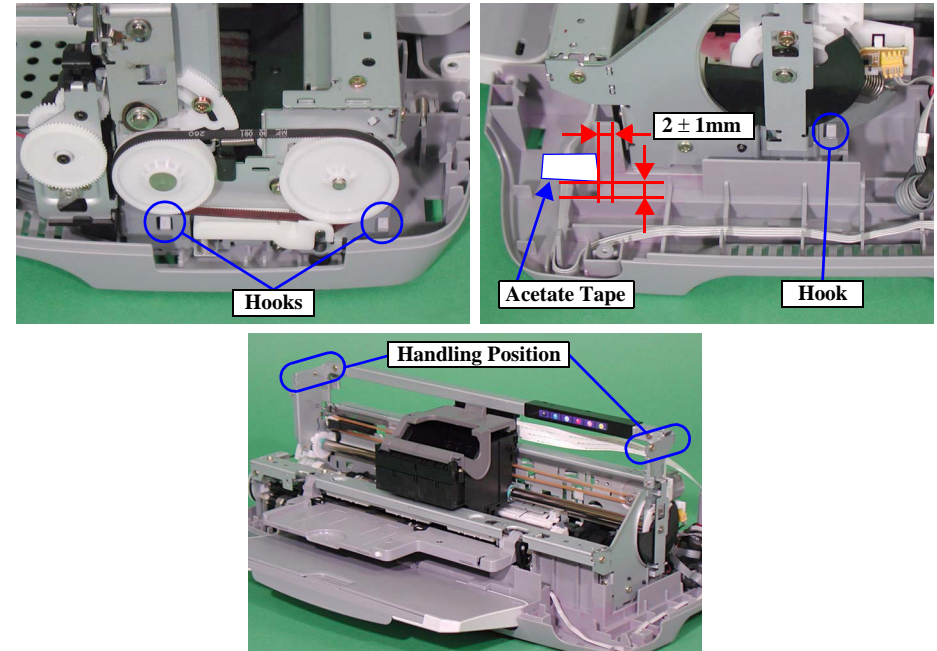

Figure 2-39. Removing "Printer Mechanism"/"Housing, Lower" (2)

### □ Parts/Units which should be removed before removing "Printer Mechanism"/"Housing, Lower"

Paper Support Assy./Housing, Upper/Housing, Middle/Main Board Unit/  
ASF Assy./Holder, Shaft Assy.

### □ Procedure for Removing

1. Move "Carriage Unit" to the centre of the printer.
2. Remove the screws (x3) which secure "Paper Guide, CDR".
3. Remove the screws (x5) which secure "Printer Mechanism".
4. Take off the acetate tape and release the connector of "Star Wheel/CDR Sensor".
5. Cut off the wire band and release the connector cable.
6. Release the hooks (x4) which secure "Printer Mechanism". Then, hold the both right and left upper edges of "Frame, Main" and remove "Printer Mechanism" to upward.





- ❑ When lifting up "Printer Mechanism", "Lever, Change" and "Combination Gear, 27.2, 19.2" may detach and drop. Take care not to drop and damage them.
- ❑ When lifting up "Printer Mechanism", take care not to leak and drip ink from the end of "Waste Ink Tube" ("Waste Ink Pads" side).
- ❑ To prevent "Frame, Main" from warping, do not lift "Printer Mechanism" holding the places which are not specified to hold.



When installing "Printer Mechanism" to "Housing, Lower", pass "Waste Ink Tube" through the hook indicated in the figure below, and securely set it in the groove, so that "Porous Pad, Ink Eject, Upper, Support" will not float from the tube. If installed insecurely, it may cause the ink leakage.

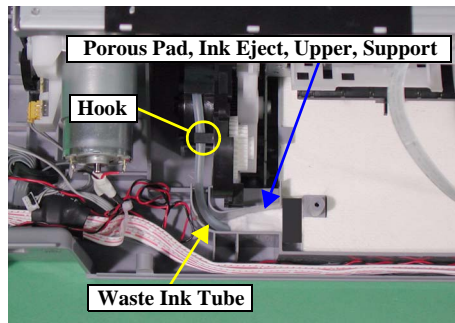

Figure 2-40. Installing "Waste Ink Tube"



- ❑ Reinstalling "Printer Mechanism"
  - For this printer, "Housing, Lower" is the standard to correctly install each part of "Printer Mechanism". In order to ensure the accuracy for installing, it is necessary to manage the reference position for "Frame, Main" installation in X, Y and Z direction as shown in the figure below. If every part is set correctly, "Printer Mechanism" can be secured with the hooks (x4).

[X-axis]

- Make sure that "Frame, Main" is installed correctly to the groove of "Housing, Lower".
- Make sure that there is no gap between "Frame, Main" and "Housing, Lower".

[Y-axis]

Make sure that the slot of "Frame, Main" is correctly installed to the projection of "Housing, lower".

[Z-axis]

- Make sure that there is no gap between "Frame, Main" and "Housing, Lower"
- Make sure that the left side of "Printer Mechanism" is correctly secured with the hooks (x2).

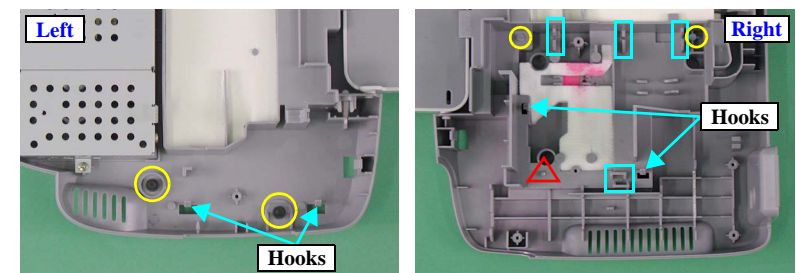

X-axis : □ (4 points)  
 Y-axis : △ (1 point)  
 Z-axis : ○ (4 points)

Figure 2-41. Reference position for installing "Frame, Main"



- Make sure that "Waste Ink Pads" (x6) are set correctly to the rib and the dowel of "Housing, Lower".

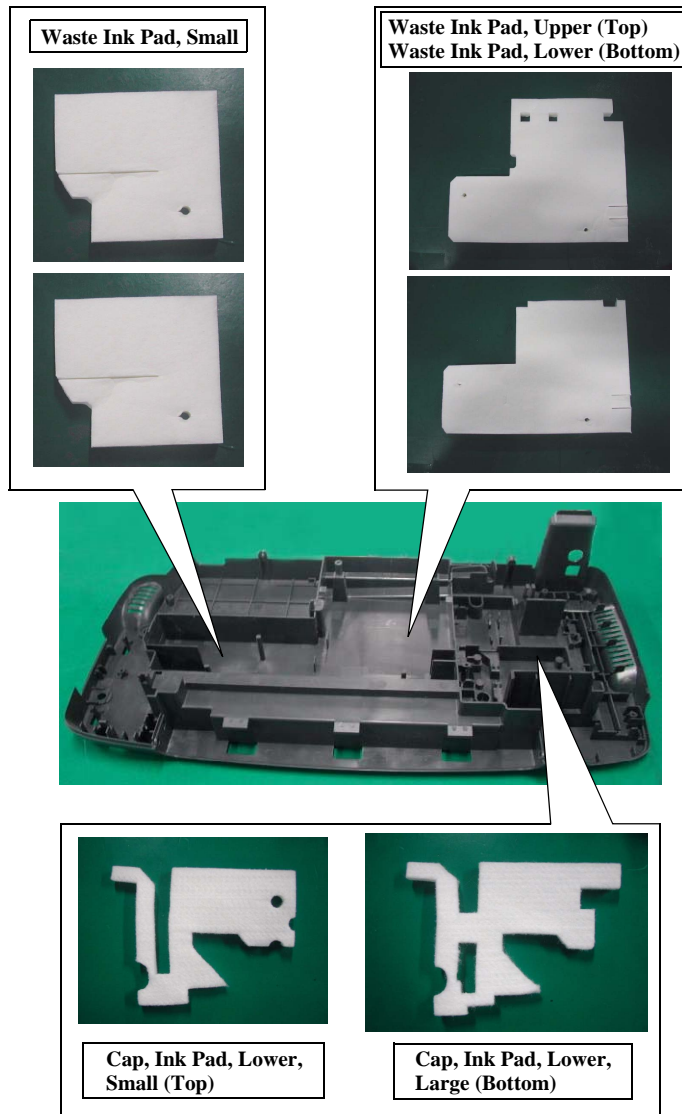

Figure 2-42. Installing "Waste Ink Pads" (1)

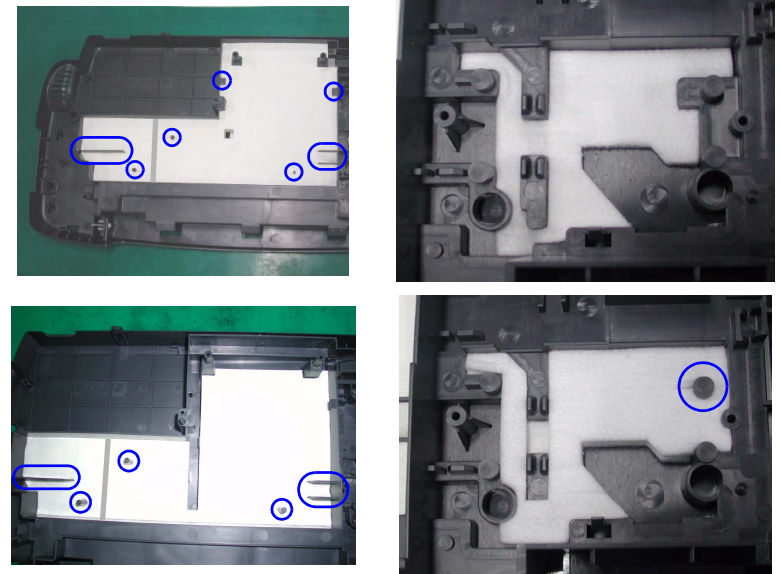

Figure 2-43. Installing "Waste Ink Pads" (2)

- After checking "Waste Ink Tube" is under "Waste Ink Pad, Lower", put the jig on the indicated points in the figure below, then install "Porous Pad, Ink Eject, Upper, Support".

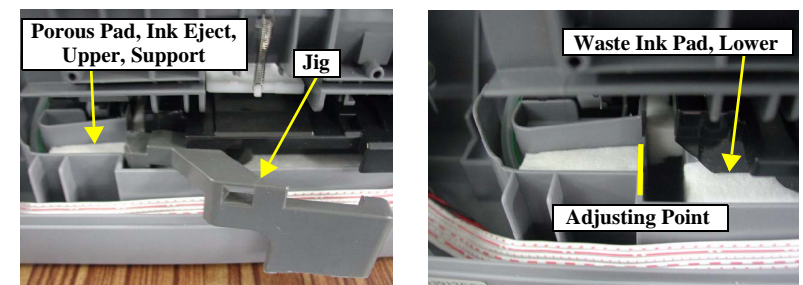

Figure 2-44. Installing "Porous Pad, Ink Eject, Upper, Support"



- Screw "Printer Mechanism" and "Paper Guide, CDR" in the order as shown in the figure.
- Check if "Waste Ink Tube" is secured in the groove of "Housing, Lower", then make sure that the line mark on the tube is facing to the left. (Also make sure that it is not twisted.)

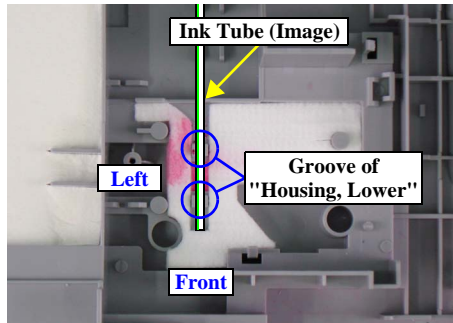

Figure 2-45. Position for installing "Ink Tube"

- Make sure that "Waste Ink Tube" is not squashed or pressed.
- Check if "Cap Assy." moves smoothly.



- When having replaced "Waste Ink Pads" with new ones, implement the following adjustment. (Refer to Chapter 3 "ADJUSTMENT")
  - Waste Ink Pad Counter

## 2.3.16 Removing Power Supply Unit

### □ External View

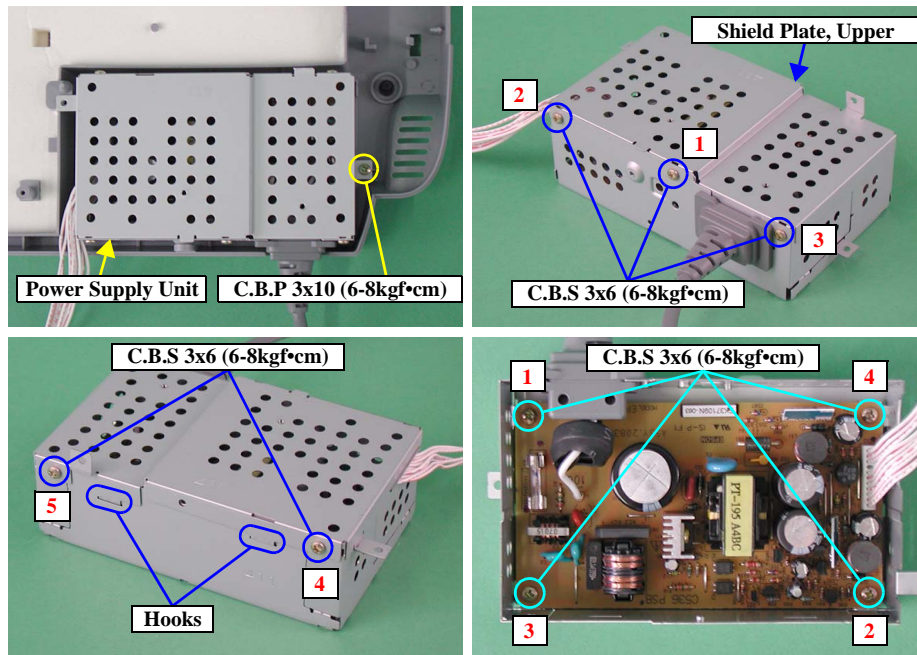

Figure 2-46. Removing "Power Supply Unit"

### □ Parts/Units which should be removed before removing "Power Supply Unit"

Paper Support Assy./Housing, Upper/Housing, Middle/Main Board Unit/  
ASF Assy./Holder, Shaft Assy./Printer Mechanism

### □ Procedure for Removing

1. Remove the screw which secures "Power Supply Unit". Then, Remove "Power Supply Unit".
2. Remove the screws (x5) which secure "Shield Plate, Upper".
3. Release the hooks (x2) which secure "Shield Plate, Upper", and then remove "Shield Plate, Upper".
4. Remove the screws (x4) which secure "PSB/PSE Board", and then remove "PSB/PSE Board".



### □ Reinstalling "PSB/PSE Board"

- Make sure to screw in the order as shown in the figure.

### □ Reinstalling "Shield Plate, Upper"

- Check if the "Power connector cable" is in between the two shield plates.
- Check if "Shield Plate, Upper" is correctly installed.
- Make sure to screw in the order as shown in the figure.



### □ When replacing "Power Supply Unit" with a new one, implement the following adjustment. (Refer to Chapter 3 "ADJUSTMENT")

- Offset Input for CR Motor Calorific Limitation

### 2.3.17 Removing CDR Guide Assy.

#### □ External View

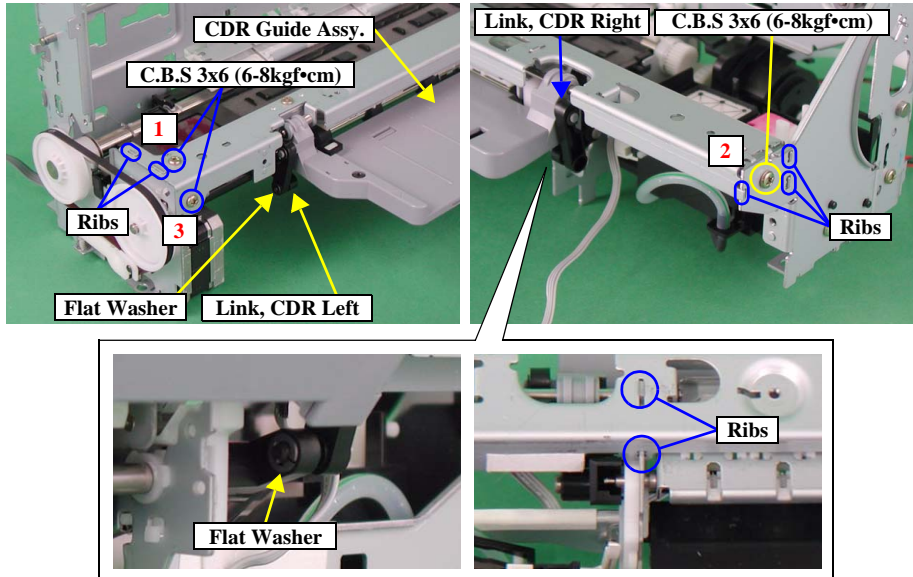
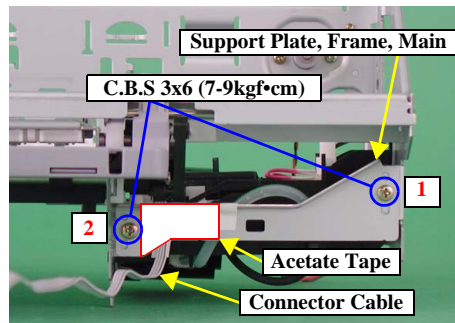

Figure 2-47. Removing "CDR Guide Assy." (1)

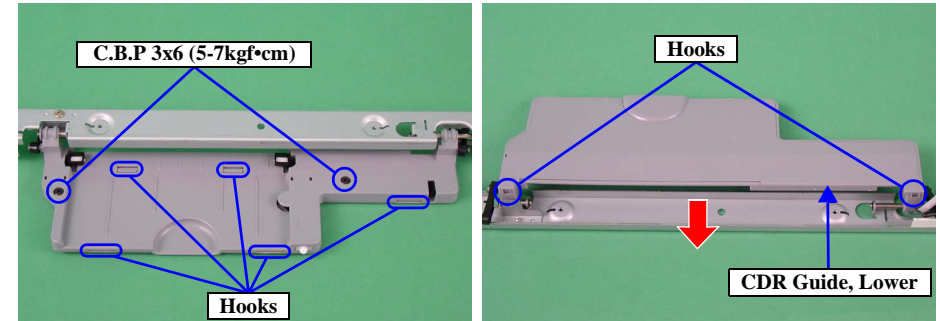

Figure 2-48. Removing "CDR Guide Assy." (2)

#### □ Parts/Units which should be removed before removing "CDR Guide Assy."

Paper Support Assy./Housing, Upper/Housing, Middle/Main Board Unit/ASF Assy./Holder, Shaft Assy./APG Assy./Print Head/Carriage Unit/Printer Mechanism

#### □ Procedure for Removing

1. Take off the acetate tape and release the connector cable of "Star Wheel/ CDR Sensor".
2. Remove the screws (x2) which secure "Support Plate, Frame, Main". Then, remove "Support Plate, Frame, Main".
3. Remove the screws (x3) which secure "CDR Guide Assy.".
4. Remove the flat washer which secure "Link, CDR Left (Right)" with the tweezers. Then, Remove "Link, CDR Left (Right)" from "CDR Guide Assy.".
5. Release the ribs (x7) which secure "CDR Guide Assy.", then remove "CDR Guide Assy." through the right edge.
6. Remove the screws (x2) which secure "CDR Guide, Lower".
7. Slide "CDR Guide, Lower" and then release the hooks (x7). After that, remove "CDR Guide, Lower".

□ External View

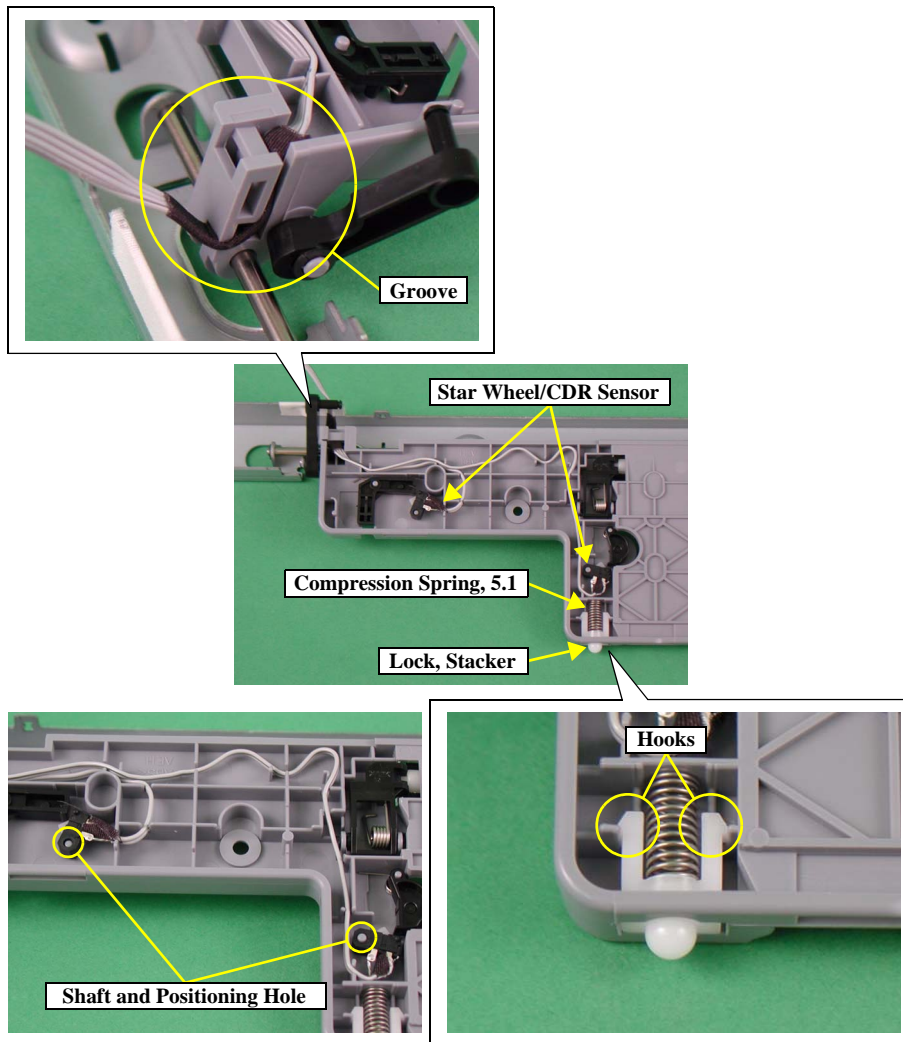

Figure 2-49. Removing "CDR Guide Assy." (3)

8. Remove "Compression Spring, 5.1" and "Lock, Stacker" from "CDR Guide, Upper".

9. Release the connector cable of "Star Wheel/CDR Sensor" from the groove of "CDR Guide, Upper".



- Reinstalling "Star Wheel/CDR Sensor"
- Match the Shaft (x2) of "CDR Guide, Upper" and the positioning hole of "Star Wheel/CDR Sensor".
  - Mount correctly the connector cable of "Star Wheel/CDR Sensor" referring to the figure.
- Reinstalling "CDR Guide, Upper"
- Make sure that the hooks (x2) of "Lock Stacker" are properly secured by the tension of "Compression Spring, 5.1".
  - Make sure that "CDR Guide, Upper" is securely secured with the hooks (x7) of "CDR Guide, Lower" and there is no gap between "CDR Guide, Upper" and "CDR Guide, Lower".
- Reinstalling "CDR Guide Assy."
- Install "CDR Guide Assy." in the order of left edge, right edge and middle.
  - Match the slot (x6) of "CDR Guide Assy." and the ribs (x6) of "Frame, Main".
  - Check if "Link, CDR Left (Right)" is correctly installed.
  - Check if the connector cable of "Star Wheel/CDR Sensor" is not interrupting "Link, CDR Right".
  - Check if "Frame, EJ Assy." works with "CDR Guide Assy." and moves smoothly.

## 2.3.18 Removing Ink System

### □ External View

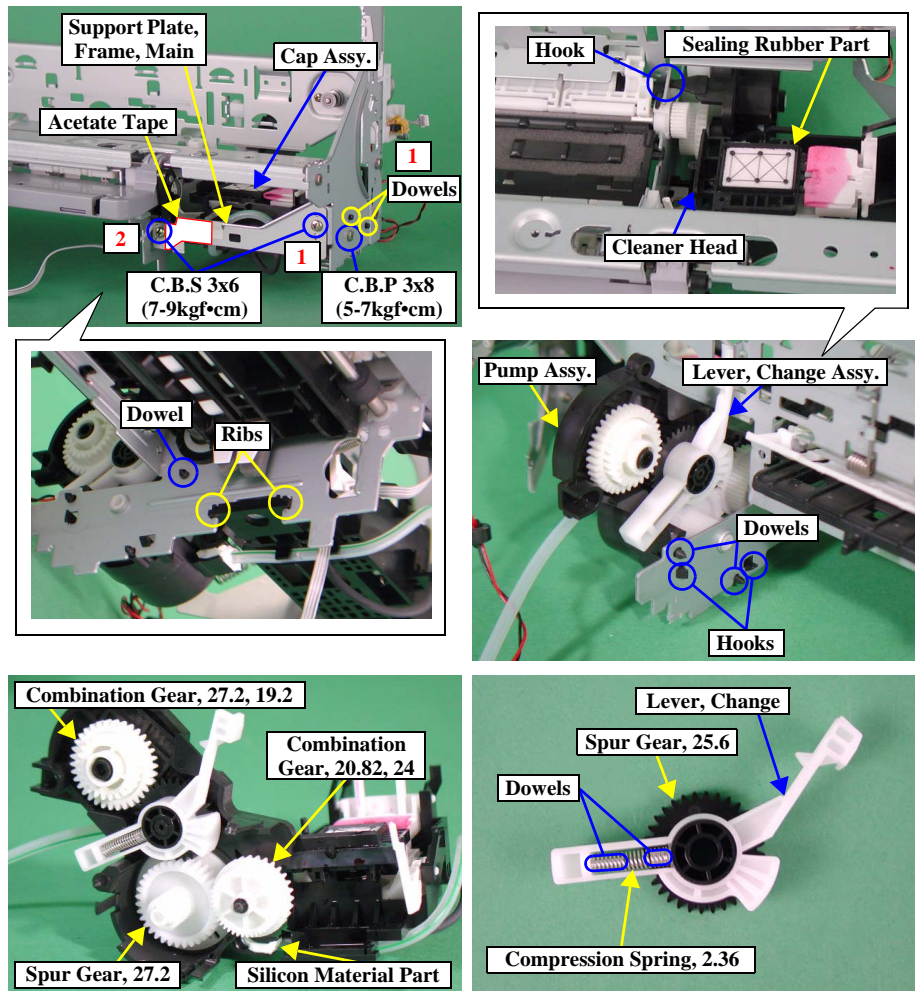

Figure 2-50. Removing "Ink System" (1)

### □ Parts/Units which should be removed before removing "Ink System"

Paper Support Assy./Housing, Upper/Housing, Middle/Main Board Unit/  
ASF Assy./Holder, Shaft Assy./Printer Mechanism

### □ Procedure for Removing

1. Take off the acetate tape, then release the connector cable of "Star Wheel/CDR Sensor".
2. Remove the screws (x2) which secure "Support Plate, Frame, Main", and remove "Support Plate, Frame, Main".
3. Remove the screw which secures "Cap Assy.".
4. Slide "Cap Assy." inward "Printer Mechanism" and release the dowels (1 : x2). Then, remove "Cap Assy." from the ribs (x2) of "Frame Main".



- Do not remove the ink tube which is connected to "Cap Assy." and "Pump Assy.".
- The ink tube cannot be removed from "Pump Assy." since it is secured with silicon material for the following reasons.
  - To prevent "Pump Assy." from ink leakage.
  - To adjust the length of the ink tube extended from "Pump Frame".

5. Release the hooks (x3) and the dowels (x3) which secure "Pump Assy.", and hold on "Lever, Change Assy." and all the gears in order not to let them drop, then remove "Cap Assy." and "Pump Assy." together.
6. Remove "Combination Gear, 20.82, 24", "Spur Gear, 27.2", "Lever, Change Assy." and "Combination Gear, 27.2, 19.2" from "Pump Assy.".
7. Remove "Spur Gear, 25.6" from "Lever, Change".
8. Remove "Compression Spring, 2.36" from the dowel of "Lever, Change".

□ External View

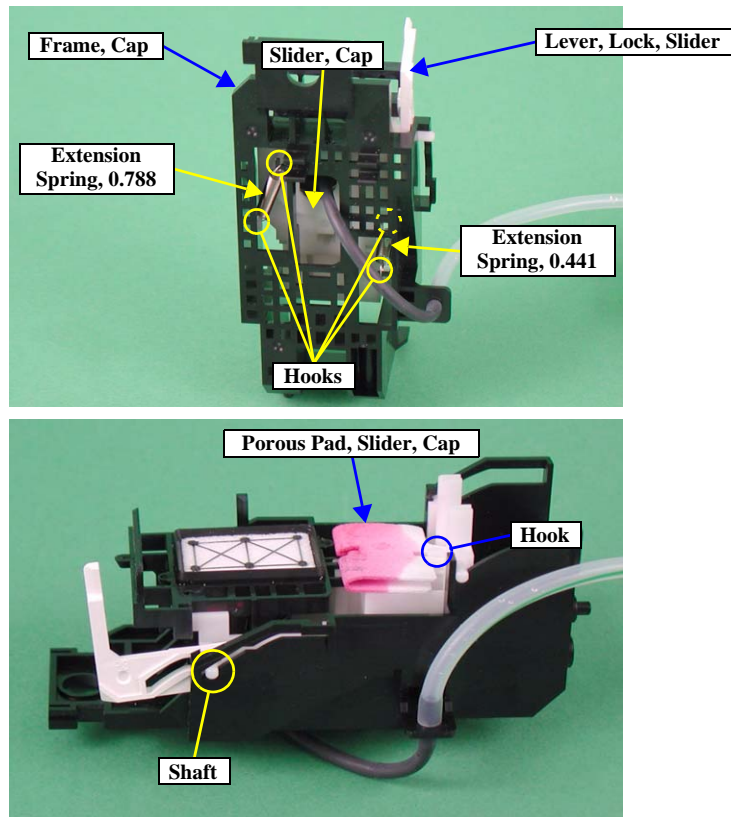

Figure 2-51. Removing "Ink System" (2)

9. Remove "Extension Spring, 0.441" from the hooks of "Slider, Cap" and "Frame, Cap" by using the tweezers.
10. Remove "Extension Spring, 0.788" from the hooks of "Lever, Lock, Slider" and "Frame, Cap" by using the tweezers.
11. Remove the shaft of "Slider, Cap" from the slot of "Frame, Cap", then remove "Lever, Lock, Slider".
12. Remove "Porous, Slider, Cap" from the hook of "Slider, Cap".



- Reinstalling "Lever, Lock, Slider"
  - Check if it works properly working with "Slider, Cap".
- Reinstalling "Ink System"
  - Make sure that the ink tube is correctly connected to the point of "Frame, Cap" shown in the figure below. If it is not connected properly, it may cause ink leakage.

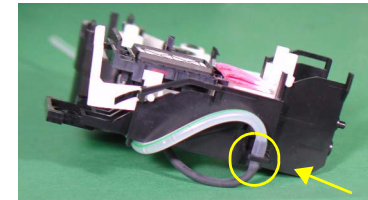

Figure 2-52. Connecting Point for the ink tube

- Do not touch the sealing rubber part and "Cleaner Head".
- Make sure that the line mark of the ink tube is not twisted.
- Check if "Cap Assy." moves smoothly.





- Set all of the gears on the shaft of "Pump Frame" correctly, and then check if they move smoothly.
- Make sure that the ink tube is not squashed or pressed.
- Install the ink tube to the grooves (x2) at the bottom surface of "Cap Frame".

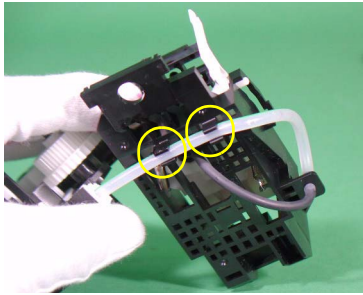

Figure 2-53. Installing Point for the ink tube

- Reinstalling "Ink System"
  - Check if "Pump Assy." is correctly secured.
  - Do not let "Lever, Change", "Combination Gear, 27.2, 19.2", "Spur Gear, 27.2" and "Combination Gear, 20.82, 24" drop and break them.

### 2.3.19 Removing Paper Guide, Front/"Roller EJ Assy."

#### □ External View

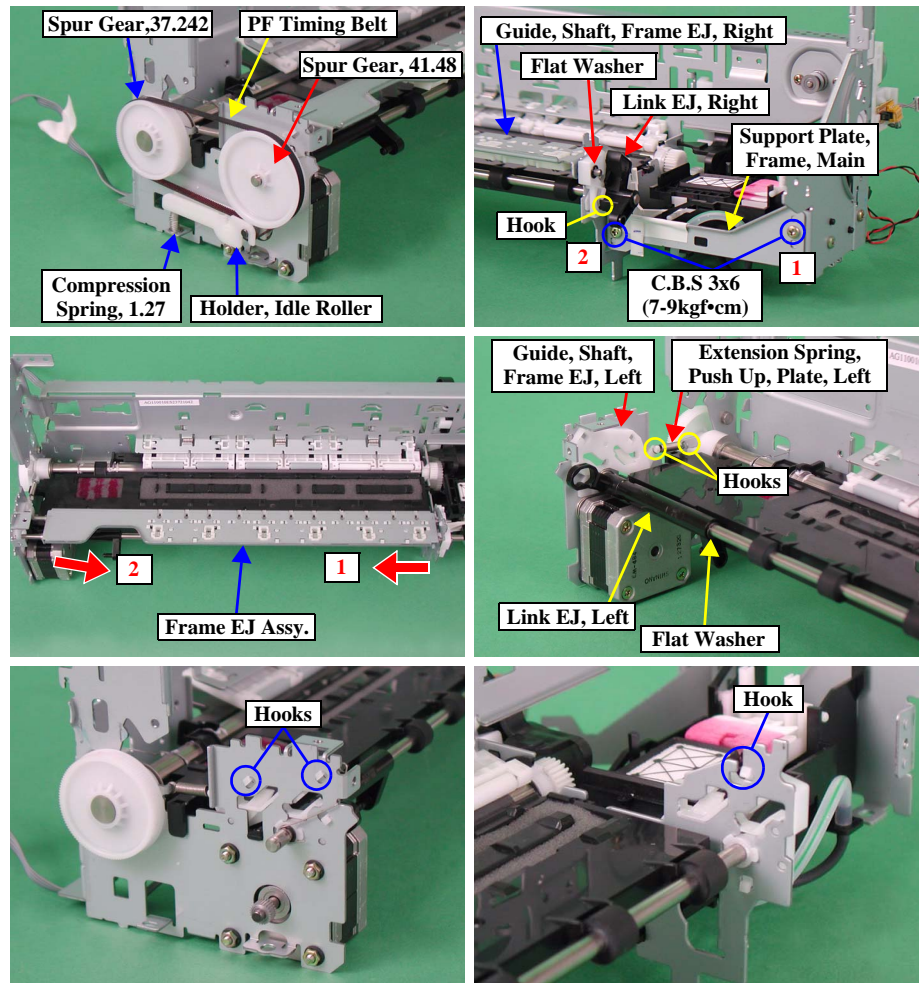

Figure 2-54. Removing "Paper Guide, Front"/"Roller EJ Assy." (1)

#### □ Parts/Units which should be removed before removing "Paper Guide, Front"/"Roller EJ Assy."

Paper Support Assy./Housing, Upper/Housing, Middle/Main Board Unit/ ASF Assy./Holder, Shaft Assy./APG Assy./Print Head/Carriage Unit/ Printer Mechanism/CDR Guide Assy.

#### □ Procedure for Removing

1. Remove the screws (x2) which secure "Support Plate, Frame, Main". Then, remove "Support Plate, Frame, Main".
2. Release the hook of "Link EJ, Right" from the groove of "Guide, Shaft, Frame EJ, Right". Then, remove "Link EJ, Right".
3. Remove the flat washer which secures the right side of "Frame EJ Assy.".
4. Remove "PF Timing Belt" from "Spur Gear, 37.242", then remove "Spur Gear, 41.48".
5. Remove "Compression Spring, 1.27" and "Holder, Idle Roller" together with "PF Timing Belt".
6. Move back "Carriage Unit" to the home position, and then remove "Frame EJ Assy." in the direction of the arrow, also in the order indicated in the figure.

#### CAUTION



When removing "Frame EJ Assy.", take care not to damage or transform "Star Wheels" of "Frame EJ Assy.".

7. Remove the flat washer which secures "Link EJ, Left", then Slide "Link EJ, Left" to the right.
8. Remove "Extension Spring, Push Up, Plate, Left" from the hooks of "Guide, Shaft, Frame EJ, Left" and "Frame, Main".
9. Release the hooks (Left x2, right x1) which secure "Guide, Shaft, Frame EJ, Left (Right)". Then, remove "Guide, Shaft, Frame EJ, Left (Right)".

External View

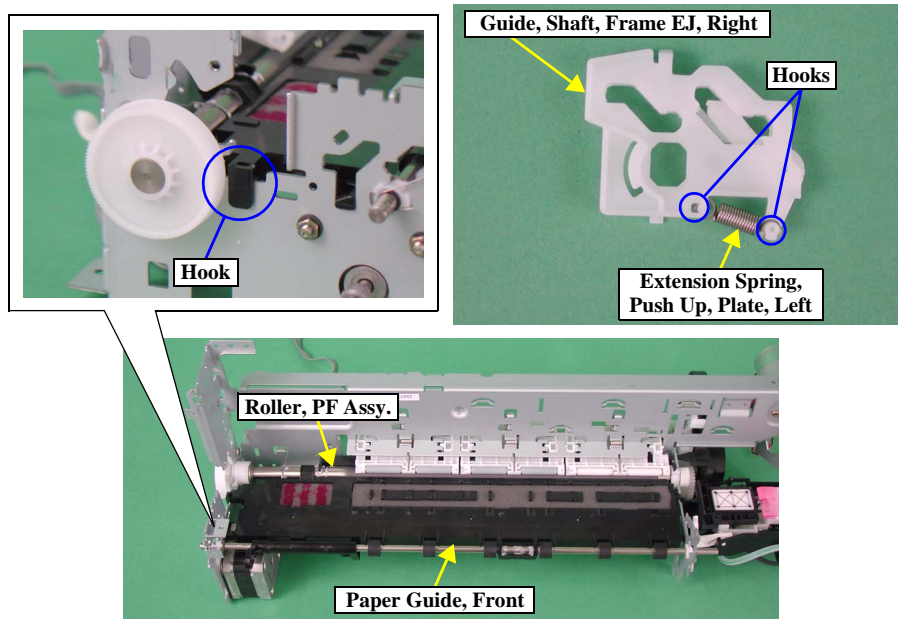

Figure 2-55. Removing "Paper Guide, Front"/"Roller EJ Assy." (2)

10. Remove "Extension Spring, Push Up, Plate, Right" from the hooks (x2) of "Guide, Shaft, Frame EJ, Right".
11. Release the hook which secures "Paper Guide, Front", then remove "Paper Guide, Front".
12. Remove "Porous Pad, Paper Guide, Front" (x4) and "Porous Pad, Paper Guide, Front, Support" from "Paper Guide, Front" by using the tweezers.



- Do not touch "Porous Pad, Paper Guide, Front".
- Do not damage the rib located on the upper surface of "Paper Guide, Front".
- Take care not to damage the surface of "Roller, PF Assy.".

□ External View

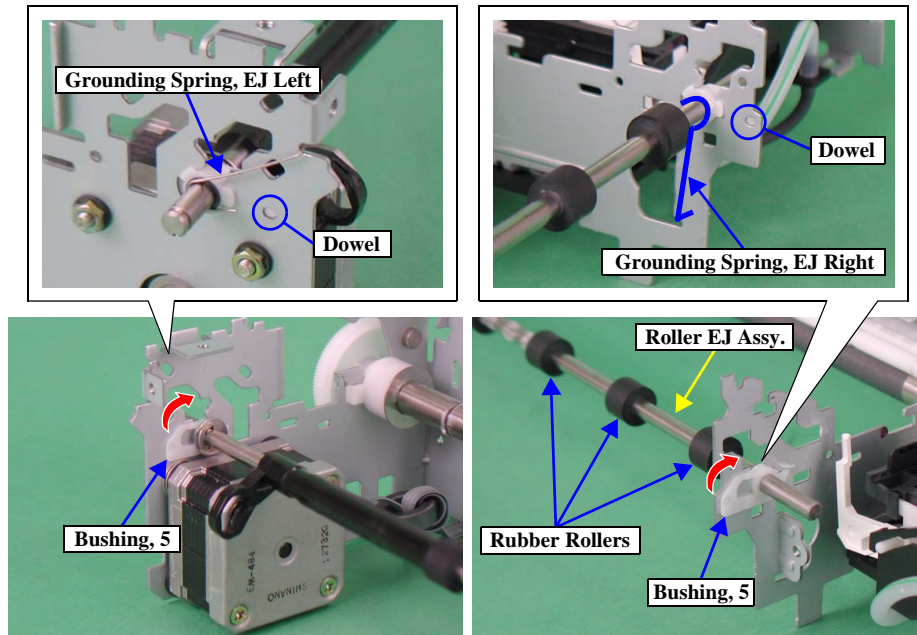

Figure 2-56. Removing "Paper Guide, Front"/"Roller EJ Assy." (3)

13. Remove "Grounding Spring, EJ Left (Right)" from "Roller EJ Assy.".
14. Release the dowels of both left and right "Bushing, 5" which secure "Roller EJ Assy.", then turn them in the direction of the arrow.
15. Pull out the right "Bushing, 5" rightward, and pull out the left edge of "Roller EJ Assy." from "Frame, Main" through its left side.



**When removing "Roller EJ Assy.", do not damage the rubber rollers.**



- Reinstalling "Paper Guide, Front"
  - Make sure that the dowels and the hook of "Paper Guide, Front" are correctly secured to "Frame, Main".

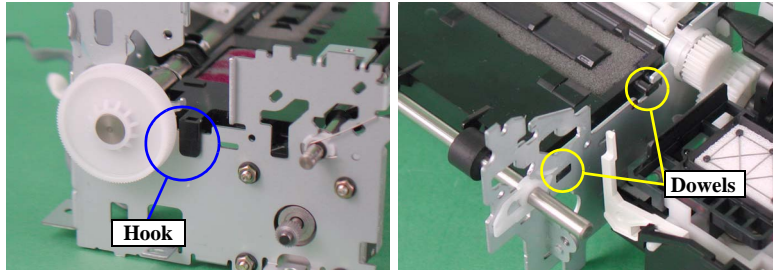

Figure 2-57. Reinstalling "Paper Guide, Front"

- Make sure that the tabs of "Porous Pad, Paper Guide, Front, Left" and "Porous Pad, Paper Guide, Front, Support" are facing straight to downward through the slots of "Paper Guide, Front".
- Make sure that there is no gap between "Paper Guide, Front" and "Frame, Main".
- If any ink leaks on the rib of "Paper Guide, Front", clean it with a cotton swab. (At this time, take care not to touch "Porous Pad, Paper Guide, Front" of "Paper Guide, Front" with the cotton swab.)
- Reinstalling "Roller EJ Assy."
  - Make sure that both left and right "Bushing, 5" are correctly secured.
  - Make sure that "Grounding Spring, EJ Left (Right)" is correctly attached to the both ends of "Roller EJ Assy.".
  - When installing "PF Timing Belt", do not damage the teeth of "Spur Gear, 41.48".
  - Make sure that "Roller EJ Assy." moves smoothly.



- When replacing "Roller EJ Assy.", apply G-26 grease in the adequate dose to the specified points.
- When removing or replacing "PF Timing Belt", implement the tension adjustment with the digital tension gauge.
- When having removed or replaced "Paper Guide, Front", implement the following adjustment. (Refer to Chapter 3 "ADJUSTMENT")
  1. First Dot Adjustment
  2. PW Sensor Adjustment
  3. Head Angular Adjustment
  4. Bi-D Adjustment

## 2.3.20 Removing PF Motor

### □ External View

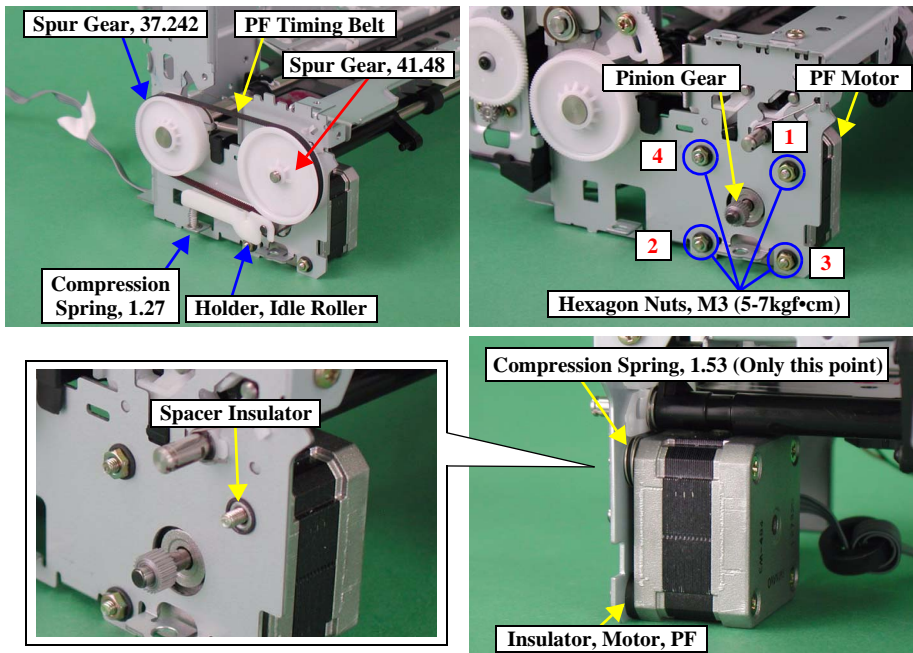

Figure 2-58. Removing "PF Motor"

### □ Parts/Units which should be removed before removing "PF Motor"

Paper Support Assy./Housing, Upper/Housing, Middle/Main Board Unit/  
ASF Assy./Holder, Shaft Assy./Printer Mechanism

### □ Procedure for Removing

1. Remove "PF Timing Belt" from "Spur Gear, 37.242", then remove "Spur Gear, 41.48".
2. Remove "Compression Spring, 1.27" and "Holder, Idle Roller" together with "Timing Belt".
3. Remove the nuts (x4) which secure "PF Motor", then remove "PF Motor".



- When removing "PF Motor", do not damage the pinion gear.
- When removing "PF Motor", "Compression Spring, 1.53" may detach and drop. Be careful not to lose it.



### □ Reinstalling "PF Motor"

- Make sure to tighten the nuts of "PF Motor" in the order shown in the figure.
- Make sure that there is no gap between "Spacer, Insulator" and "Frame, Main".

CHAPTER

3

ADJUSTMENT

## 3.1 Adjustment Items and Overview

This chapter describes adjustments to be made after the disassembly/reassembly of this product.

### 3.1.1 Servicing Adjustment Item List

The adjustment items of this product are as follows. For details of the adjustment items, refer to the detailed procedures and sketches of the adjustment items.

**Table 3-1. Adjustment Items**

Function Item		Purpose	Method Outline	Tool	Used Media
Adjustment items	Market Setting	At the time of Main Board replacement, this adjustment is made to write the board common information on a destination basis.	Select and execute this function in the exclusive servicing program to save the following data into the EEPROM. Market ID, CSIC Printer ID, D4 Setting (USB, Parallel), First Dot Adjustment fixed value.	Exclusive servicing program	Non-target
	USB ID Input	This adjustment is made to allow the PC to recognize the connected printers individually when multiple printers of the same model are connected and used with the PC via a USB hub.	Select this function in the exclusive servicing program and enter the serial numbers of the printers. The correction value is saved to the specific EEPROM address on the Main Board.	Exclusive servicing program	Non-target
	Head ID Input	At the time of Print Head replacement, this adjustment is made to correct head manufacturing variations and eliminate the individual differences of print quality.	Enter the ID of the Head QR code label applied to the Print Head into the exclusive servicing program to save it to the EEPROM on the Main Board. (Supplement: Read the QR code label from left to right on the top row and from top to bottom in due order.)	Exclusive servicing program	Non-target
	Head Angular Adjustment	This adjustment is made to correct the error in the Print Head mounting position (angle of the Print Head to the paper surface) to keep the nozzle intervals uniform in the CR main scanning direction.	Select this function in the exclusive servicing program and print the adjustment pattern. Check the displacement amount of the pattern. Print the exclusive pattern again and adjust the displacement amount.	Exclusive servicing program	Photo Quality Ink Jet Paper (A4)
	Bi-D Adjustment	This adjustment is made to correct the print timing in the go and return paths in bi-directional printing. (This printer carries out printing with PG (typ.) and PG (-))	Select this function in the exclusive servicing program and print the adjustment patterns to check the displacement amounts of the patterns. Select/enter the pattern number that has the smallest displacement amount in the program. Print the exclusive patterns again and adjust the displacement amount. The correction value is saved into the EEPROM.	Exclusive servicing program	Plain paper (A4)
	PW Sensor Adjustment	This adjustment is made to correct the mounting position of the PW Sensor on a software basis to minimize the paper detection error caused by the variations of the mounting position.	Select this function in the exclusive servicing program and print the adjustment patterns. Select the pattern number 5mm away from each edge, and enter that number in the program. The correction value is saved to the specific EEPROM address on the Main Board.	Exclusive servicing program	Photo Paper / Glossy Photo Paper (A4)



Table 3-1. Adjustment Items

Function Item		Purpose	Method Outline	Tool	Used Media
Adjustment items	First Dot Adjustment	This adjustment is made to correct the First Dot Position in the CR main scanning direction.	Select and execute this function in the exclusive servicing program. Enter the correction value in the program using the rule position of the print pattern as a reference. The correction value is saved to the specific EEPROM address on the Main Board.	Exclusive servicing program	Plain paper (A4)
	Offset Input for CR Motor Calorific Limitation	When the Main Board, CR Motor or PSB/PSE Board is changed individually, this adjustment is made to write the maximum offset to prevent the occurrence of damage to the motor at the time of CR Motor heat generation.  However, when the CR Guide Shaft is changed together with the above part, this adjustment is made to measure the manufacturing variations of the CR Motor and PSB/PSE Board, utilize the motor capability to the maximum for motor heat generation control, and prevent the motor from being damaged by CR Motor heat generation.	Select and execute this function in the exclusive servicing program to save the offset into the EEPROM.	Exclusive servicing program	Non-target

Table 3-2. Maintenance Functions

Function Item		Purpose	Adjustment Outline	Tool	Used Media
Maintenance items	Head Cleaning	This function is used to execute Cleaning efficiently when ink is not delivered from the Head properly, e.g. dot missing or skewed injection. This function is used together with the Nozzle Check Pattern to confirm the Cleaning effects.	Select this function in the exclusive servicing program, and execute CL 3.	Exclusive servicing program	Non-target
	Ink Charge	This function is used to drain the Shipping Liquid in the ASP Print Head flow path and simultaneously fill ink in the head flow path to make all nozzles printable and stabilize the ink in the Print Head.	Select this function in the exclusive servicing program, and execute the ink sucking operation equivalent to the Initial Charge.	Exclusive servicing program	Non-target
	Waste Ink Pad Counter	This function is used after repair to read the Waste Ink Counter, and if the value is close to the predetermined near-end value or end value, to recommend Pad replacement to the user in order to prevent the repaired printer from being returned again for repair in a short time. The reset function is used to reset the Waste Ink Counter from the exclusive program after Waste Ink Pad replacement.	Select this function in the exclusive servicing program, read/display the current data from the specific EEPROM address on the Main Board, and check whether the current counter value is close to the upper limit or not.  For the reset function, select this function in the exclusive servicing program after Waste Ink Pad replacement, and reset the corresponding data at the specific address in the EEPROM on the Main Board.	Exclusive servicing program	Non-target
	EEPROM Data Copy	This function is used to read the above necessary information from the EEPROM of the faulty Main Board using the D4 function to reduce the auxiliary adjustment items at the time of Board replacement.	Select this function in the exclusive servicing program, and read the data from the faulty board. After that, change the Main Board and then write the read data to a new board.	Exclusive servicing program	Non-target

Table 3-3. Check Pattern Printing

Function Item		Purpose	Adjustment Outline	Tool	Used Media
Check pattern items	A4 Normal Paper Print	This pattern is used to check whether all adjustment results are normal.	Select this function in the exclusive servicing program, print the print patterns, and check the adjustment result in each pattern.	Exclusive servicing program	Plain paper (A4)
	A4 Photo Quality Ink Jet Paper Print	This pattern is used to check whether all adjustment results are normal.	Select this function in the exclusive servicing program, print the print patterns, and check the adjustment result in each pattern.	Exclusive servicing program	Photo Quality Ink Jet Paper (A4)
	A4 Photo Paper/ Glossy Photo Paper Print	This pattern is used to check whether all adjustment results are normal.	Select this function in the exclusive servicing program, print the print patterns, and check the adjustment result in each pattern.	Exclusive servicing program	Glossy Photo Paper (A4)
	CD-R Print	Check if the center position of CDR is correct.	This pattern is used to make a simple print check at the EPSON service company.	Exclusive servicing program	Sheet, CD, Dummy
	Nozzle Check Pattern Print	This pattern is used to check simply whether all nozzles deliver ink or not.	This pattern is used to make a simple print check at the EPSON service company.	Exclusive servicing program	Plain paper (A4)

Table 3-4. Appendix

Function Item		Purpose	Adjustment Outline	Tool	Used Media
Appendix items	Save All EEPROM Data	This function is used to analyze defective products.	Save the data of all EEPROM addresses.	Exclusive servicing program	Non-target
	APG Check	This function is used to check if APG Assy. works properly.	Select this function in the exclusive servicing program, and check the CR Guide Shaft movement.	Exclusive servicing program	Non-target

### 3.1.2 Replacement Part-Based Adjustment Priorities

The following table shows the adjustment items and their order for the replacement parts.

Note: "Required" in this table indicates the adjustment items that must be implemented when the corresponding parts/units have been removed or replaced. "Recommended", on the other hand, indicates those which are recommended the adjustment after removing or replacing them. "-" means the adjustment is not needed. When having removed or replaced more than one part/unit, refer to the items that correspond to the parts/units.

Table 3-5. Adjustment Item

Performance Priority	1	2	3	4	5	6	7	8	9	10	11	12
	EEPROM Data Copy	Market Setting	USB ID Input	Waste Ink Pad Counter	Ink Charge	Head ID Input	PG Adjustment	First dot Adjustment	PW Sensor Adjustment	Head Angular Adjustment	Bi-d Adjustment	Offset Input for CR Motor Calorific Limitation
"ASF Unit" Removal	-	-	-	-	-	-	-	Required	-	-	-	-
"ASF Unit" Replacement	-	-	-	-	-	-	-	Required	-	-	-	-
"CR Motor" Removal	-	-	-	-	-	-	-	Required	Required	Recommended	Required	-
"CR Motor" Replacement	-	-	-	-	-	-	-	Required	Required	Recommended	Required	Required
"Paper Guide Upper" Removal	-	-	-	-	-	-	-	-	-	-	-	-
"Paper Guide Upper" Replacement	-	-	-	-	-	-	-	-	-	-	-	-
"Front Frame" Removal	-	-	-	-	-	-	-	-	-	-	-	-
"Front Frame" Replacement	-	-	-	-	-	-	-	-	-	-	-	-
"CR Unit" Removal	-	-	-	-	-	-	Required	Required	Required	Recommended	Required	-
"CR Unit" Replacement	-	-	-	-	-	-	Required	Required	Required	Recommended	Required	-
"Print Head" Removal	-	-	-	-	-	-	Required	Required	Required	Required	Required	-
"Print Head" Replacement	-	-	-	-	Required	Required	Required	Required	Required	Required	Required	-
"Main Board" Removal	-	-	-	-	-	-	-	-	-	-	-	-
"Main Board" Replacement (Read OK)	Required	-	-	-	-	-	-	-	-	-	-	-
"Main Board" Replacement (Read NG)	-	Required	Required	Required (Replacing Waste Ink Pads)	-	Required	-	Required	Required	Required	Required	Required
"Holder Shaft Unit" Removal	-	-	-	-	-	-	-	-	-	-	-	-
"Holder Shaft Unit" Replacement	-	-	-	-	-	-	-	-	-	-	-	-
"CR Guide Shaft" Removal	-	-	-	-	-	-	Required	Required	Required	-	Required	-
"CR Guide Shaft" Replacement	-	-	-	-	-	-	Required	Required	Required	-	Required	Required

Performance Priority	1	2	3	4	5	6	7	8	9	10	11	12
	EEPROM Data Copy	Market Setting	USB ID Input	Waste Ink Pad Counter	Ink Charge	Head ID Input	PG Adjustment	First dot Adjustment	PW Sensor Adjustment	Head Angular Adjustment	Bi-d Adjustment	Offset Input for CR Motor Calorific Limitation
"Paper Eject Roller" Removal	-	-	-	-	-	-	-	-	-	-	-	-
"Paper Eject Roller" Replacement	-	-	-	-	-	-	-	-	-	-	-	-
"PSB/PSE Board" Removal	-	-	-	-	-	-	-	-	-	-	-	-
"PSB/PSE Board" Replacement	-	-	-	-	-	-	-	-	-	-	-	Required
"Paper Guide Front" Removal	-	-	-	-	-	-	-	Recommended	Recommended	Recommended	Required	-
"Paper Guide Front" Replacement	-	-	-	-	-	-	-	Recommended	Recommended	Recommended	Required	-
"PF Motor" Removal	-	-	-	-	-	-	-	-	-	-	-	-
"PF Motor" Replacement	-	-	-	-	-	-	-	-	-	-	-	-
"Waste Ink Pads" Removal	-	-	-	-	-	-	-	-	-	-	-	-
"Waste Ink Pads" Replacement	-	-	-	Required	-	-	-	-	-	-	-	-
"PW Sensor" Removal	-	-	-	-	-	-	-	-	Required	-	-	-
"PW Sensor" Replacement	-	-	-	-	-	-	-	-	Required	-	-	-
"Printer Mechanism" Removal *1)	-	-	-	-	-	-	Recommended	-	-	-	-	-
"Printer Mechanism" Replacement *1)	-	-	-	-	-	-	Recommended	-	-	-	-	-
"Ink System" Removal	-	-	-	-	-	-	-	-	-	-	-	-
"Ink System" Replacement	-	-	-	-	-	-	-	-	-	-	-	-

\*1) The adjustment has been completed at the unit level of ASP supply. However, since "Main Board", "Print Head" and "ASF" are supplied separately, refer to the each item that corresponds to the part/unit.

## 3.2 Adjustment by using adjustment program

---

The procedures of the adjustment items will be explained here. The intended item is as follows.

- Market Setting
- USB ID Input
- Head ID Input
- Head Angular Adjustment
- Bi-d Adjustment
- PW Sensor Adjustment
- First Dot Adjustment
- Offset Input for CR Motor Calorific Limitation
- A4 Normal Paper Print
- A4 Photo Quality Inkjet Paper Print
- A4 Photo Paper/ Glossy Photo Paper Print

### 3.2.1 Market Setting

[Adjustment Procedure]

1. Select the Market Setting of the Adjustment Program.
2. Click the [OK] button to write the specific data into EEPROM.
3. Click the [Check] button to check market and model name.

### 3.2.2 USB ID Input

[Adjustment Procedure]

1. Select USB ID in the Adjustment Program.
2. Enter the 10-digits serial number from the label applied to the back side of the Housing Middle.

### 3.2.3 Head ID Input

[Adjustment Procedure]

1. Select the Head ID of the Adjustment Program.
2. Enter the 15-digits code of the Head ID label applied to the Print Head. Enter the Head ID from left to right on the top row and from top to bottom in due order.

### 3.2.4 Head Angular Adjustment

[Adjustment Procedure]

1. Select Head Angular Adjustment in the Adjustment Program.
2. Click the [Print] button to print Head Angular Adjustment Pattern of checked items.
3. Select the pattern value of straight line in the printed lines.
4. Click the [input] button and write the adjustment value.  
(Note: The range of the adjustment value is -3 to 3.)

[Treatment procedure for NG product]

1. Replace the Print Head with new one again.
2. Print the check pattern, and check the adjustment result.
3. If the result is NG level, confirm the installation condition of removed parts during disassembly.
4. Perform step2) again.

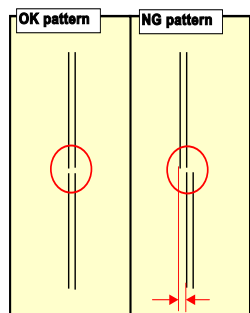

[Judging Standard]  
 - The printed line should be straight line.  
 [Reference: Standard value in manufactory]  
 - Standard:  $\pm 50\mu\text{m}$

Figure 3-1. Head Angular Printing Pattern

### 3.2.5 Bi-d Adjustment

[Adjustment Procedure]

1. Select Bi-D Adjustment in the Adjustment Program.
2. Click the [Print] button to print Bi-D Adjustment Pattern of checked items.
3. After selecting the pattern that has the smallest misalignment in each variable dot, click the [Go to input page] button in the Adjustment Program.
4. Click the [Input] button to write the adjustment value of checked items.
5. Click the [Go to print page] button.

[Treatment procedure for NG product]

1. Replace the Print Head with new one again.
2. Print the check pattern, and check the adjustment result.
3. If the result is NG level, confirm the installation condition of removed parts during disassembly.
4. Perform step2) again.

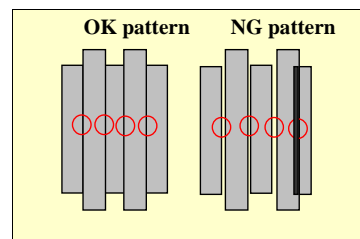

[Judging Standard]  
 - No gap/overlap between short block pattern and long one.  
 [Reference: Standard value in manufactory]  
 VSD1:  $60\mu\text{m}$ ,  
 VSD2:  $60\mu\text{m}$ ,  
 VSD3:  $40\mu\text{m}$ ,  
 VSD4:  $40\mu\text{m}$ ,  
 ECO:  $85\mu\text{m}$ .

Figure 3-2. Bi-D Adjustment Pattern

### 3.2.6 PW Sensor Adjustment

[Adjustment Procedure]

1. Select PW Sensor Adjustment in the Adjustment Program.
2. Click the [Print] button to print PW Sensor Adjustment Pattern.
3. Select the pattern number 5mm away from each edge.
4. Click the [Input] button to write the adjustment value of checked items.

[Treatment procedure for NG product]

1. Replace the PW sensor with new one again.
2. Print the check pattern, and check the adjustment result.
3. If the result is NG level, confirm the installation condition of removed parts during disassembly.
4. Perform step2) again.

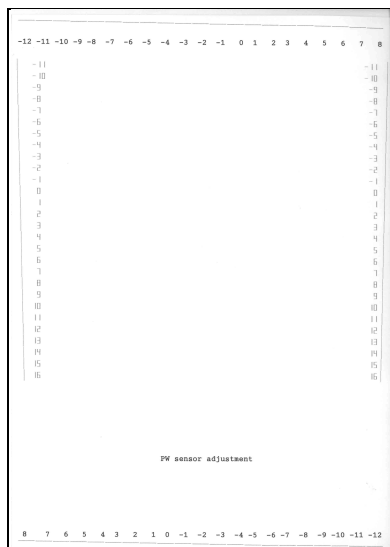

Figure 3-3. PW Sensor Adjustment Pattern

[Judging Standard]

- Top / Bottom: 3.7 to 6.0mm
- Right / Left : 4.0 to 5.5mm

### 3.2.7 First Dot Adjustment

[Adjustment Procedure]

1. Select First Dot Adjustment in the Adjustment Program.
2. Click the [Print] button to print First Dot Adjustment Pattern.
3. Determine the adjustment value in the shifting direction for the pattern printed on the left margin. Input can be made in 0.0176mm increments for the adjustment value of 1.
4. Click the [input] button and write the adjustment value.

[Treatment procedure for NG product]

1. Replace the repaired (replaced) part with new one.
2. Print the check pattern, and check the adjustment result.
3. If the result is NG level, confirm the installation condition of removed parts during disassembly.

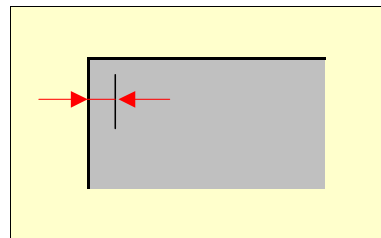

[Judging Standard]

- Standard:  $3 \pm 1.0$ mm away from left edge.

Figure 3-4. First Dot Adjustment

### 3.2.8 Offset Input for CR Motor Calorific Limitation

[Adjustment Procedure]

1. Select Offset Input for CR Motor Calorific Limitation in the Adjustment Program.
2. Check each box of the replaced parts/units checklist and then click the [OK] button.

### 3.2.9 A4 Normal Paper Print

[Adjustment Procedure]

1. Select A4 Normal Paper Print in the Adjustment Program.
2. Click the [Print] button to print A4 Normal Paper Print Pattern.
3. Check the adjustment result in each pattern.

### 3.2.10 A4 Photo Quality Inkjet Paper Print

[Adjustment Procedure]

1. Select A4 Photo Quality Inkjet Paper Print in the Adjustment Program.
2. Click the [Print] button to print A4 Photo Quality Inkjet Paper Print Pattern.
3. Check the adjustment result in each pattern.

### 3.2.11 A4 Photo Paper/ Glossy Photo Paper print

1. Select A4 Photo Paper/ Glossy Photo Paper print in the Adjustment Program.
2. Click the [Print] button to print A4 Photo Paper/ Glossy Photo Paper print Pattern.
3. Check the adjustment result in each pattern.



### 3.3 Adjustment Except Adjustment Program

Following is adjustment except Adjustment Program.

#### 3.3.1 PG Adjustment

[Purpose]

This adjustment is required when removing or replacing the following parts/units in order to secure the specified space between the print-side of the Print Head and the paper.

- Carriage Unit
- CR Guide Shaft
- Bushing, Parallel Adjust, Left (Right)  
(Including when having moved "Bushing Parallel Adjust, Left (Right)")

[Adjustment Procedure]

1. Make both sides of the two Thickness Gauge (1.15mm and 1.31mm) clean by wiping with Bemcot with a little alcohol.
2. To make the PG position minus (-), turn the gear of "APG Assy." and match the flag centre of "Cam, CR, Right" with "PG Sensor".

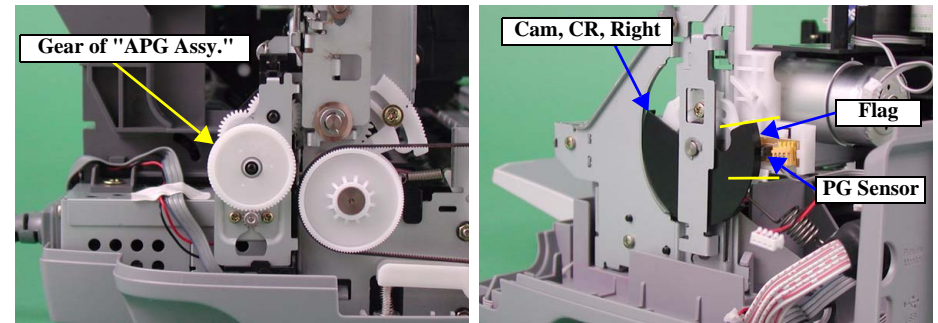

Figure 3-5. Setting PG Position

3. Match the 0 position (Hole point of gear) of "Bushing, Parallel Adjust, Left (Right)" with the rib of "Frame, Main".

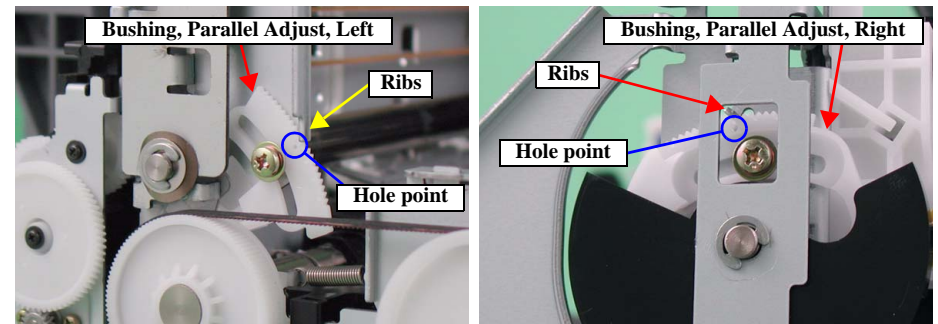

Figure 3-6. Setting "Bushing, Parallel Adjust"

4. Move "Carriage Unit" to the centre of the printer and remove "Lever, Cartridge". Then, set the PG-Adjustment Dummy Cartridge.

5. Move "Carriage Unit" to the left edge of the printer, then set the Thickness Gauge (1.15mm) on the left ribs (X3) of "Paper Guide, Front".



Figure 3-7. Setting Thickness Gauge

7. Remove the Thickness Gauge and move "Carriage Unit" to the right edge. Then, set the Thickness Gauge on the right ribs (X3) of "Paper Guide, Front".

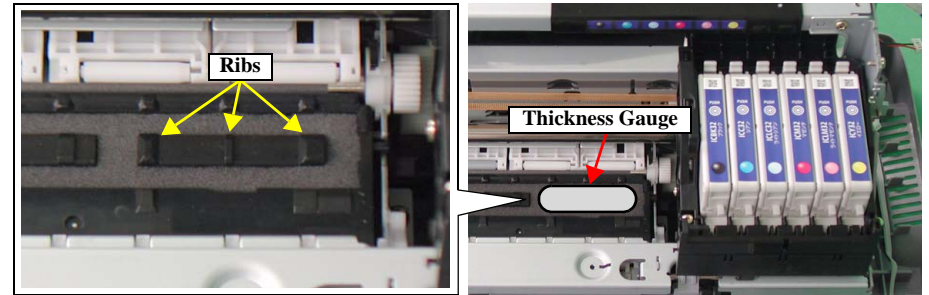

Figure 3-9. Setting Thickness Gauge

6. Implement PG Adjustment on the left according to the flowchart in the Figure 3-8.

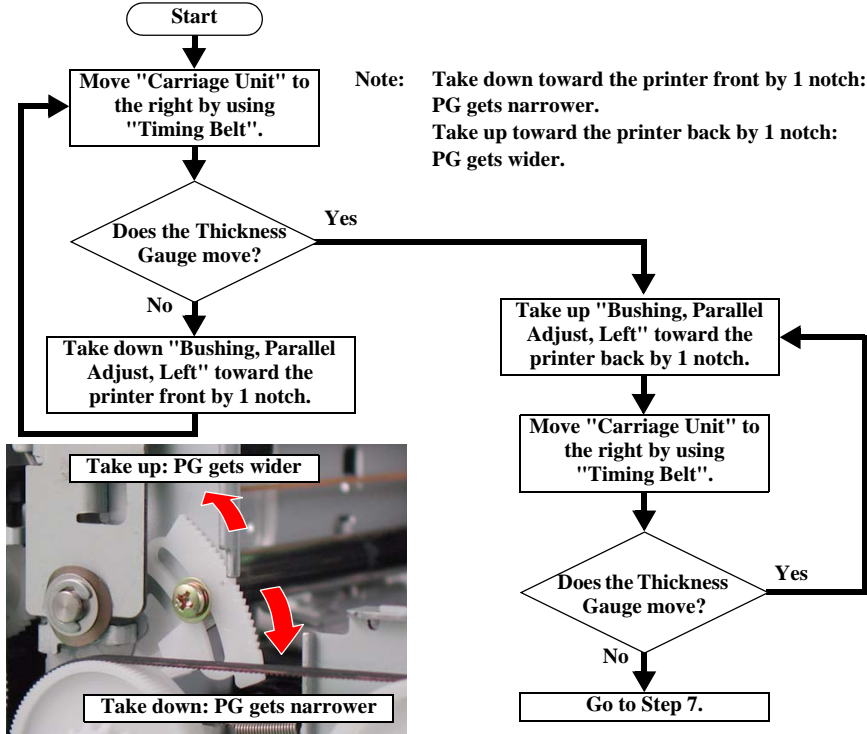

Figure 3-8. PG Adjustment (Left Side)

8. Implement PG Adjustment on the right according to the flowchart in the Figure 3-10.

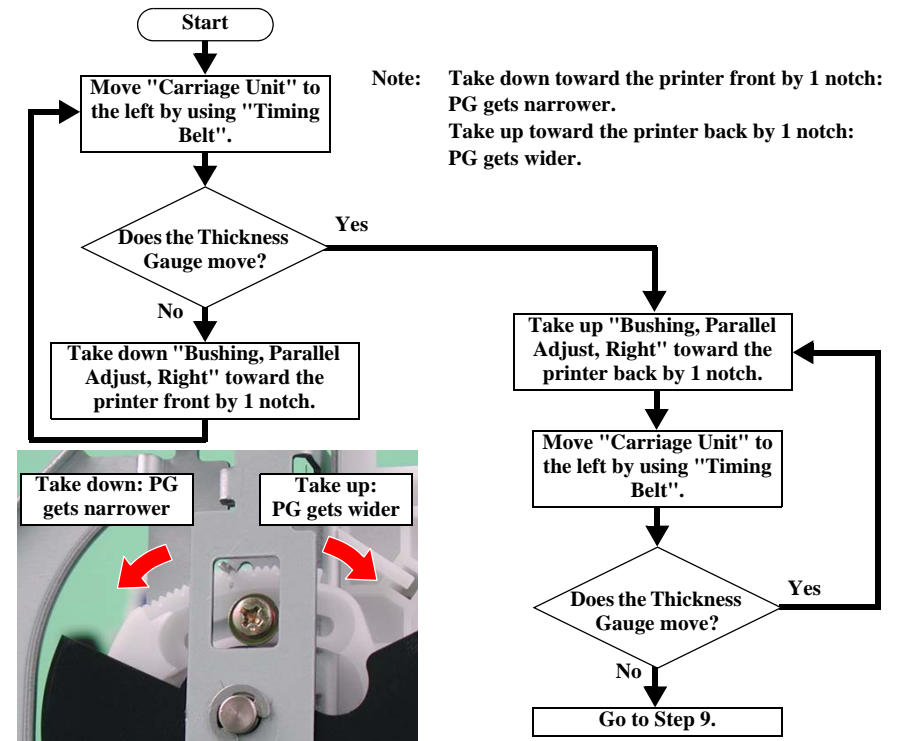

Figure 3-10. PG Adjustment (Right Side)

- After finishing PG Adjustment on the right, move "Carriage Unit" to the left edge again, then check PG according to the flowchart in the Figure 3-11.

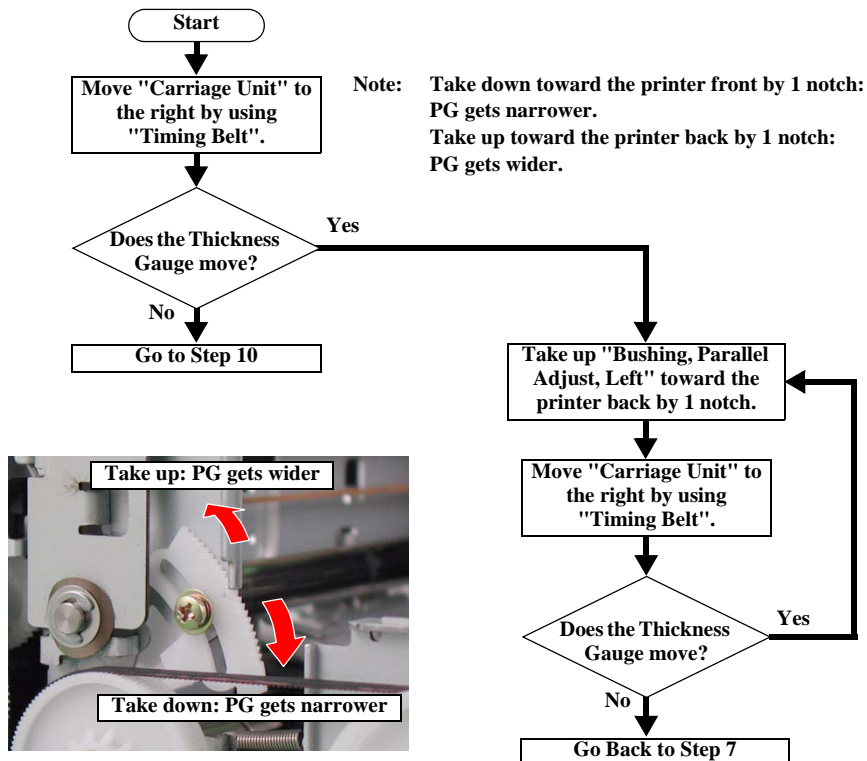

Figure 3-11. PG Checking (1)

- Move "Carriage Unit" back to the left edge of the printer, then set the Thickness Gauge (1.31mm) on the ribs (X3) of "Paper Guide, Front" in the same way as the Figure 3-7.

- Check PGs on both the left and right according to the flowchart in the Figure 3-12.

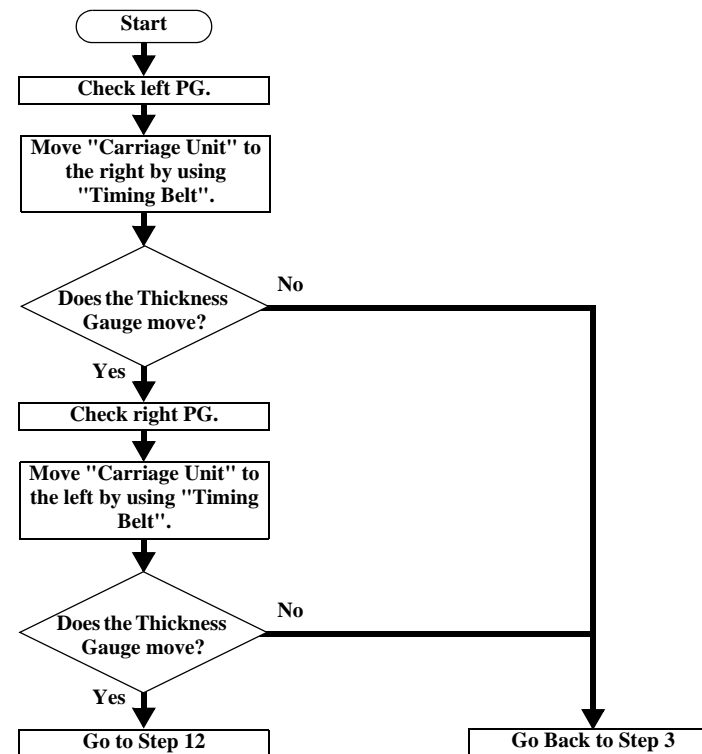

Figure 3-12. PG Checking (2)

- After finishing the adjustment, screw "Bushing, Parallel Adjust, Left (Right)".
- After screwing, check PGs on both the left and right again according to the flowchart in the Figure 3-12.

**CHAPTER**

**4**

**MAINTENANCE**

## 4.1 Overview

This section provides information to maintain the printer in its optimum condition.

### 4.1.1 Cleaning

This printer has no mechanical components which require regular cleaning except the Print Head. Therefore, when returning the printer from the user, check the following parts and perform appropriate cleaning if stain is noticeable.



- **Never use chemical solvents, such as thinner, benzine, and acetone to clean the exterior parts of the printer like the housing. These chemicals may deform the components of the printer or deteriorate the quality of the printer.**
- **Be careful not to damage any components when you clean inside the printer.**
- **Do not scratch the surface of the PF Roller. Use a soft brush to wipe off dust. Use a soft cloth moistened with alcohol to remove ink stain.**

#### □ Housing

Use a clean soft cloth moistened with water and wipe off any dirt. If the Housings are stained with ink, use a cloth moistened with neutral detergent to wipe it off.

#### □ Inside the printer

Use a vacuum cleaner to remove any paper dust.

#### □ LD Roller

When the paper loading function does not operate because friction of the LD Roller has gone down due to paper dust, remove the dust by using a soft brush or soft cloth moistened with alcohol.

### 4.1.2 Service Maintenance

If print irregularity (missing dot, white line, etc.) has occurred or the printer indicates "Maintenance Error", take the following actions to clear the error.

#### □ Head Cleaning

If dot missing or banding phenomenon has occurred, use the Head Cleaning function and perform the Print Head cleaning operation.\* This function can be performed by operating the control panel, the print driver utility and the Adjustment Program.

When performed by operating the Control Panel, first make sure that the printer is in stand-by status. Then, select the cleaning mode by pressing the Maintenance button on the Control Panel. The message, "Beginning head cleaning" will be displayed on LED. By pressing the OK button, the printer will start the cleaning sequence.

When selecting the manual cleaning by the printer driver utility, the most appropriate cleaning mode will be selected.

The following explanation is the operation process of the printer head cleaning by the Printer Driver Utility.

Refer to Chapter 3 "ADJUSTMENT" for the operation of the Adjustment Program.

\* This product has three modes for Manual Cleaning, and it automatically selects the best cleaning mode in accordance with the various conditions and performs the operation. Therefore, the consumption of the ink by the manual cleaning will vary according to the selected mode for the condition.

1. Select EPSON Status Monitor 3 in the Printer Driver Utility. Then make sure that the printer connected to Status Monitor 3 is on standby status. If it is on standby, the following will be displayed.



Figure 4-1. Display for Status Monitor 3

2. Select Head Cleaning in the Printer Driver Utility and execute the printer Head Cleaning. After the cleaning, choose "Nozzle Check" and print the Nozzle Check Pattern. If repeating the Print Head cleaning operation without choosing "Nozzle Check", CL1, the weakest cleaning, will be repeated.

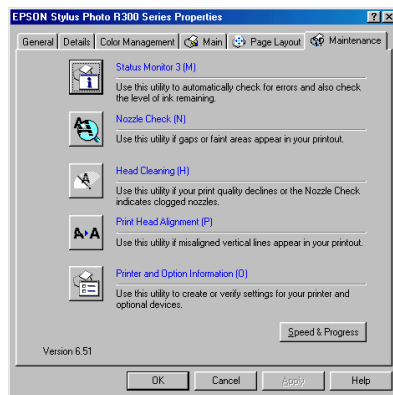

Figure 4-2. Head Cleaning Functions of the Print Driver Utility

- Maintenance Request Error

Ink is used for operations such as Head Cleaning as well as printing. In that case, the ink is drained into the Waste Ink Pad and its amount is counted in the Waste Ink Counter set in the EEPROM on the control board. When the preset value is reached (Waste Ink Counter = Waste Ink Pad Counter A = variable between 20000 and 46750), The Waste Ink Counter detects that the Waste Ink Pad has reached its predetermined limit. The Maintenance Request Error will be displayed on Status Monitor 3 as shown below.

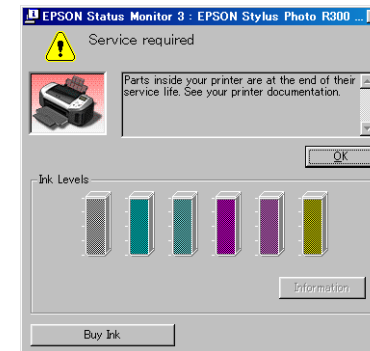

Figure 4-3. Maintenance Request Error Display on Status Monitor 3

If this occurs, replace the Waste Ink Pad and reset the Waste Ink Counter set in the EEPROM. Resetting of the Waste Ink Counter can be done only from the Adjustment Program since this product does not have the reset function for the Waste Ink Counter through the operation Panel Switch. Refer to Chapter 3 "ADJUSTMENT" for the reset procedure. During repair service, the Waste Ink Counter must be checked according to the firmware version, the Main Board checker program version and the Nozzle Check Pattern of the Nozzle Check Pattern Print. Because another "Maintenance Request Error" could occur after returning the repaired product to the user, if the Waste Ink Counter is close to its limit, it is recommended that the Waste Ink Pad be replaced.

### 4.1.3 Lubrication

The lubrication used for the components of Stylus Photo R300/R310 has been decided on based on evaluation carried out by Epson. As a result, the specified amount of lubricant should be applied in the places specified when carrying out repair and maintenance work.

- When wiping off the grease during the cleaning
- If necessary when performing assembly/disassembly of the printer



- Never use oil or grease other than those specified in this manual. Use of different types of oil or grease may damage the components or affect the printer functions.
- Never apply a larger amount of oil or grease than specified in this manual.

Table 4-1. Oil Applied to Stylus Photo R300/R310

Type	Name	EPSON Code	Supplier
Grease	G-26	1080614	EPSON
	G-46	1039172	
	G-63	1218320	



- When using G-64, it is recommended to use a flux dispenser (1049533) together.

- Refer to the following figures for the lubrication points.

<p><b>&lt;Lubrication Point&gt;</b></p> <ol style="list-style-type: none"> <li>Contact point between "Grounding Spring, PF" and "Roller, PF"</li> <li>Surface of contact point between "Roller PF" and "Paper Guide, Rear"</li> </ol>
<p><b>&lt;Lubrication Type&gt;</b></p> <ol style="list-style-type: none"> <li>G-26</li> <li>G-26</li> </ol>
<p><b>&lt;Lubrication Amount&gt;</b></p> <ol style="list-style-type: none"> <li>Half periphery of "Roller, PF"</li> <li>4mm x 2 points</li> </ol>
<p><b>&lt;Remarks&gt;</b></p> <p>Use a syringe to apply it</p>

<p><b>&lt;Lubrication Point&gt;</b></p> <p>Inside surface of "Bushing, 5" (Roller EJ Assy.)</p>
<p><b>&lt;Lubrication Type&gt;</b></p> <p>G-26</p>
<p><b>&lt;Lubrication Amount&gt;</b></p> <p>Adequate dose</p>
<p><b>&lt;Remarks&gt;</b></p> <p>Use a cotton-tipped swab to apply it</p>

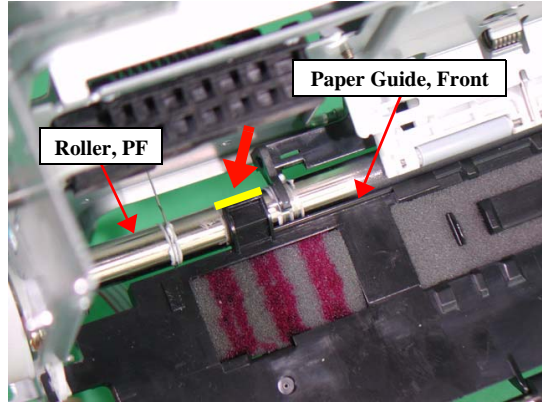
	<p>&lt;Lubrication Point&gt; Back of contact point between "Roller, PF" and hook of "Paper Guide, Front"</p> <p>&lt;Lubrication Type&gt; G-26</p> <p>&lt;Lubrication Amount&gt; 10mm</p> <p>&lt;Remarks&gt; Use a syringe to apply it</p>
---	---

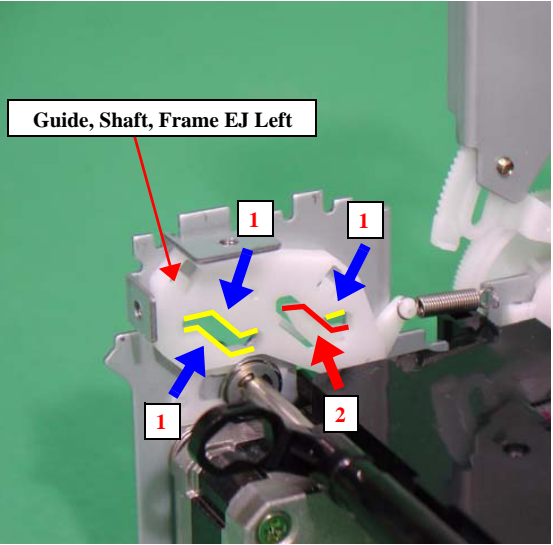
	<p>&lt;Lubrication Point&gt;</p> <ol style="list-style-type: none"> <li>1. Contact point between shaft of "Frame, EJ" and inside "Guide, Shaft, Frame EJ Left"</li> <li>2. Contact point between shaft of "Frame, EJ" and upper surface of "Push Up Plate Frame EJ Left"</li> </ol> <p>&lt;Lubrication Type&gt;</p> <ol style="list-style-type: none"> <li>1. G-26</li> <li>2. G-26</li> </ol> <p>&lt;Lubrication Amount&gt;</p> <ol style="list-style-type: none"> <li>1. 3 points (Adequate dose)</li> <li>1. 1 point (Adequate dose)</li> </ol> <p>&lt;Remarks&gt; Use a brush to apply it</p>
---	---

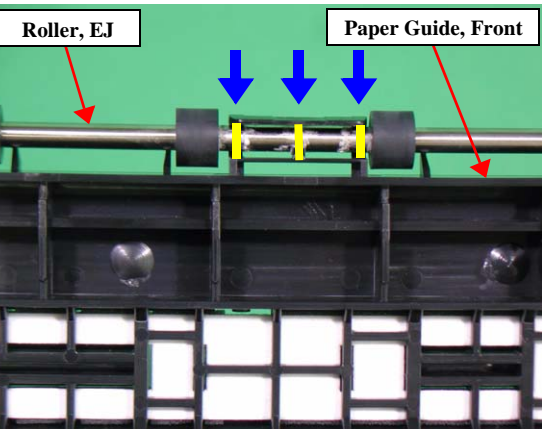
	<p>&lt;Lubrication Point&gt; Bottom of contact point between "Roller, EJ" and hook of "Paper Guide, Front"</p> <p>&lt;Lubrication Type&gt; G-26</p> <p>&lt;Lubrication Amount&gt; 3 points (Adequate dose)</p> <p>&lt;Remarks&gt; Use a cotton-tipped swab to apply it</p>
--	--

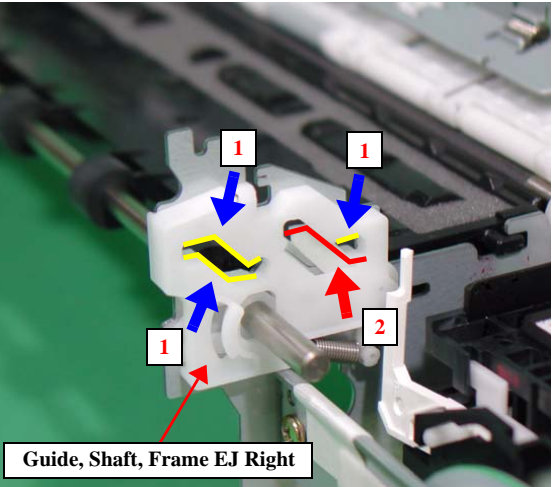
	<p>&lt;Lubrication Point&gt;</p> <ol style="list-style-type: none"> <li>1. Contact point between shaft of "Frame EJ" and inside "Guide, Shaft, Frame EJ Right"</li> <li>2. Contact point between shaft of "Frame EJ" and upper surface of "Push Up Plate Frame EJ Right"</li> </ol> <p>&lt;Lubrication Type&gt;</p> <ol style="list-style-type: none"> <li>1. G-26</li> <li>2. G-26</li> </ol> <p>&lt;Lubrication Amount&gt;</p> <ol style="list-style-type: none"> <li>1. 3 points (Adequate dose)</li> <li>1. 1 point (Adequate dose)</li> </ol> <p>&lt;Remarks&gt; Use a brush to apply it</p>
--	---

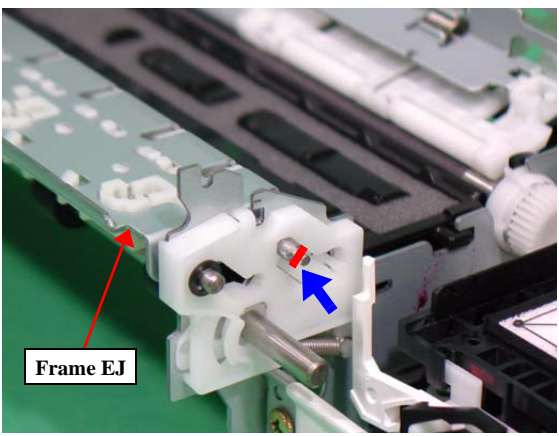

 <p data-bbox="136 523 242 547">Frame EJ</p>	<p data-bbox="683 165 902 193">&lt;Lubrication Point&gt;</p> <p data-bbox="683 201 1021 256">Right side surface of smaller shaft of "Frame EJ"</p> <hr/> <p data-bbox="683 312 902 339">&lt;Lubrication Type&gt;</p> <p data-bbox="683 347 740 375">G-26</p> <hr/> <p data-bbox="683 430 932 458">&lt;Lubrication Amount&gt;</p> <p data-bbox="683 466 946 493">Half periphery of the shaft</p> <hr/> <p data-bbox="683 517 810 544">&lt;Remarks&gt;</p> <p data-bbox="683 552 1019 608">Use a cotton-tipped swab to apply it</p>
---	---

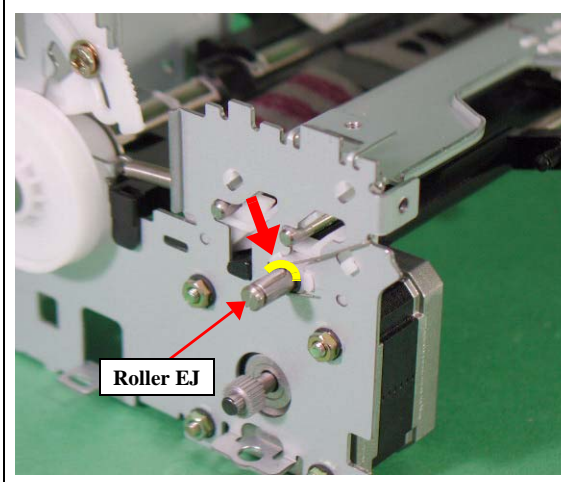
 <p data-bbox="1200 529 1306 553">Roller EJ</p>	<p data-bbox="1683 165 1902 193">&lt;Lubrication Point&gt;</p> <p data-bbox="1683 201 2021 256">Contact point between "Roller EJ" and "Ground Spring, EJ Left"</p> <hr/> <p data-bbox="1683 312 1902 339">&lt;Lubrication Type&gt;</p> <p data-bbox="1683 347 1740 375">G-26</p> <hr/> <p data-bbox="1683 430 1932 458">&lt;Lubrication Amount&gt;</p> <p data-bbox="1683 466 1832 493">Adequate dose</p> <hr/> <p data-bbox="1683 549 1810 576">&lt;Remarks&gt;</p> <p data-bbox="1683 584 1913 611">Use a brush to apply it</p>
--	---

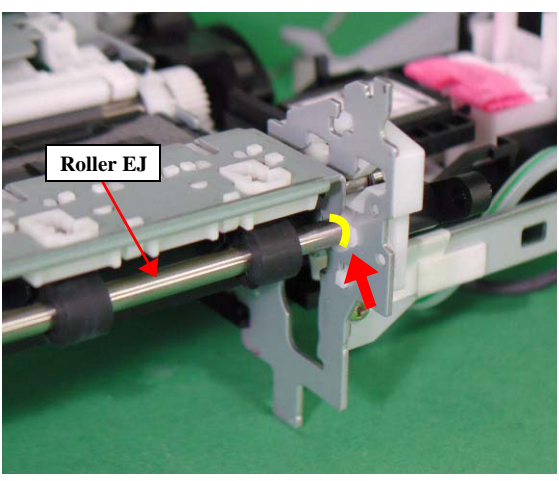
 <p data-bbox="157 869 263 893">Roller EJ</p>	<p data-bbox="683 726 902 753">&lt;Lubrication Point&gt;</p> <p data-bbox="683 761 1021 817">Contact point between "Roller EJ" and "Ground Spring, EJ Right"</p> <hr/> <p data-bbox="683 873 902 900">&lt;Lubrication Type&gt;</p> <p data-bbox="683 908 740 935">G-26</p> <hr/> <p data-bbox="683 991 932 1018">&lt;Lubrication Amount&gt;</p> <p data-bbox="683 1026 832 1053">Adequate dose</p> <hr/> <p data-bbox="683 1109 810 1136">&lt;Remarks&gt;</p> <p data-bbox="683 1144 912 1171">Use a brush to apply it</p>
---	--

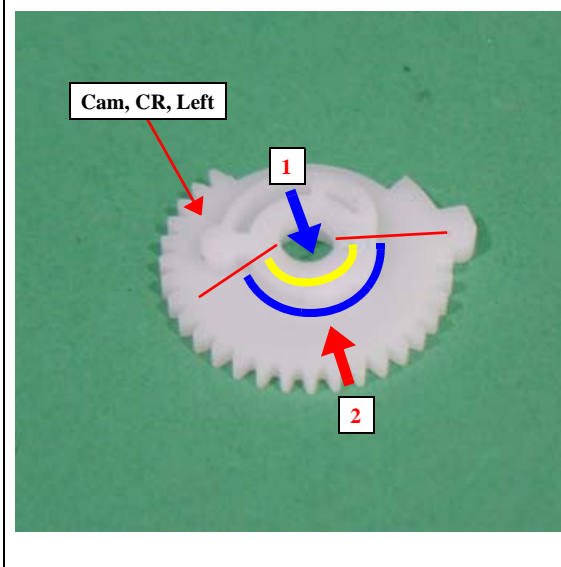
 <p data-bbox="1166 853 1315 877">Cam, CR, Left</p> <p data-bbox="1364 917 1385 941">1</p> <p data-bbox="1434 1165 1455 1189">2</p>	<p data-bbox="1683 766 1902 793">&lt;Lubrication Point&gt;</p> <ol data-bbox="1683 801 2021 1016" style="list-style-type: none"> <li>1. Surface of contact point between upper side of "Cam, CR, Left" and "Frame, Main"</li> <li>2. Surface of contact point between periphery surface of "Cam, CR, Left" and "Bushing, Parallel Adjust, Left"</li> </ol> <hr/> <p data-bbox="1683 1032 1902 1059">&lt;Lubrication Type&gt;</p> <ol data-bbox="1683 1067 1768 1123" style="list-style-type: none"> <li>1. G-63</li> <li>2. G-63</li> </ol> <hr/> <p data-bbox="1683 1149 1932 1176">&lt;Lubrication Amount&gt;</p> <ol data-bbox="1683 1184 1859 1240" style="list-style-type: none"> <li>1. Half periphery</li> <li>2. Half periphery</li> </ol> <hr/> <p data-bbox="1683 1265 1810 1292">&lt;Remarks&gt;</p> <p data-bbox="1683 1300 1913 1327">Use a brush to apply it</p>
---	--

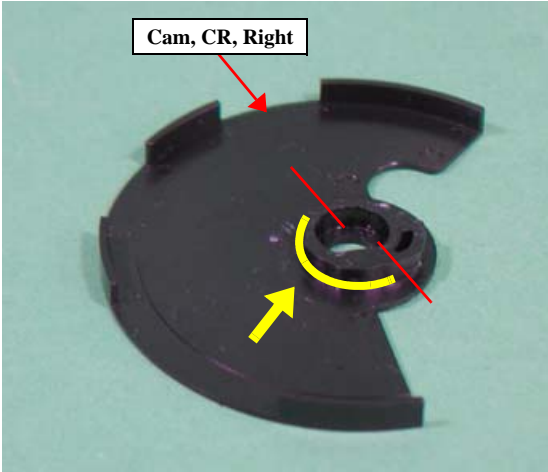
	<p>&lt;Lubrication Point&gt; Inside periphery surface of "Cam, CR, Right"</p> <p>&lt;Lubrication Type&gt; G-63</p> <p>&lt;Lubrication Amount&gt; Adequate dose</p> <p>&lt;Remarks&gt;  <ul style="list-style-type: none"> <li>• Use a brush to apply it</li> <li>• Do not apply it outside the boundary in the figure</li> </ul> </p>
---	---

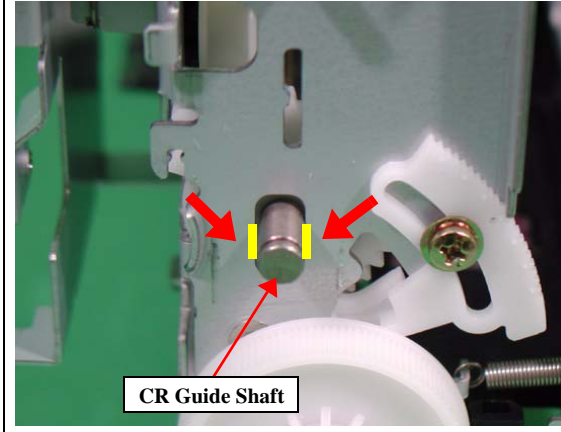
	<p>&lt;Lubrication Point&gt; Contact point between left side of "CR Guide Shaft" and "Frame, Main"</p> <p>&lt;Lubrication Type&gt; G-63</p> <p>&lt;Lubrication Amount&gt; 3mm x 2 points</p> <p>&lt;Remarks&gt; Use a syringe to apply it</p>
---	---

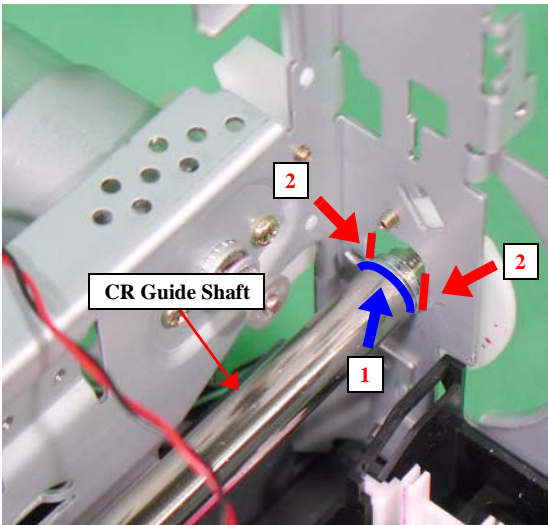
	<p>&lt;Lubrication Point&gt;  <ol style="list-style-type: none"> <li>1. Groove on the right side of "CR Guide Shaft" (Groove for "Fixed Spring, Shaft CR, Left")</li> <li>2. Contact point between right side of "CR Guide Shaft" and "Frame, Main"</li> </ol> </p> <p>&lt;Lubrication Type&gt;  <ol style="list-style-type: none"> <li>1. G-63</li> <li>2. G-63</li> </ol> </p> <p>&lt;Lubrication Amount&gt;  <ol style="list-style-type: none"> <li>1. Half periphery</li> <li>2. 3mm x 2 points</li> </ol> </p> <p>&lt;Remarks&gt; Use a syringe to apply it</p>
--	--

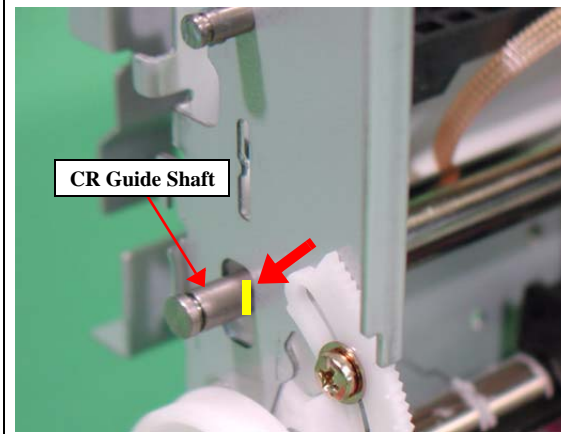
	<p>&lt;Lubrication Point&gt; Contact point between left side of "CR Guide Shaft" and "Fixed Spring, Shaft CR, Left"</p> <p>&lt;Lubrication Type&gt; G-63</p> <p>&lt;Lubrication Amount&gt; 3mm</p> <p>&lt;Remarks&gt; Use a syringe to apply it</p>
--	---

	<p><b>&lt;Lubrication Point&gt;</b> Specified points on "Holder, Scale, Left" in the figure on the left</p> <p><b>&lt;Lubrication Type&gt;</b> G-63</p> <p><b>&lt;Lubrication Amount&gt;</b> 8 points (Adequate dose)</p> <p><b>&lt;Remarks&gt;</b> Use a brush to apply it</p>
--	---

	<p><b>&lt;Lubrication Point&gt;</b> "Pulley, Driven Assy."</p> <p><b>&lt;Lubrication Type&gt;</b> G-26</p> <p><b>&lt;Lubrication Amount&gt;</b> 1mm x 4 points</p> <p><b>&lt;Remarks&gt;</b> Use a syringe to apply it</p>
--	--

	<p><b>&lt;Lubrication Point&gt;</b> Specified points on "Holder, Scale, Right" in the figure on the left</p> <p><b>&lt;Lubrication Type&gt;</b> G-63</p> <p><b>&lt;Lubrication Amount&gt;</b> 8 points (Adequate dose)</p> <p><b>&lt;Remarks&gt;</b> Use a brush to apply it</p>
--	--

	<p><b>&lt;Lubrication Point&gt;</b></p> <ol style="list-style-type: none"> <li>Upper surface of curving area of "Holder, Idle Roller"</li> <li>Lower surface of curving area of "Holder, Idle Roller"</li> </ol> <p><b>&lt;Lubrication Type&gt;</b></p> <ol style="list-style-type: none"> <li>G-26</li> <li>G-26</li> </ol> <p><b>&lt;Lubrication Amount&gt;</b></p> <ol style="list-style-type: none"> <li>2 points (Adequate dose)</li> <li>2 points (Adequate dose)</li> </ol> <p><b>&lt;Remarks&gt;</b> Use a brush to apply it</p>
--	--

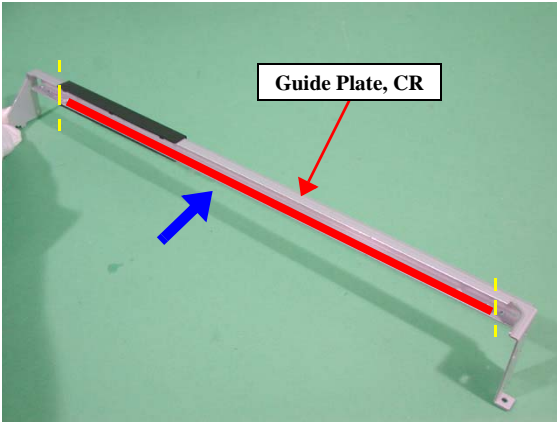
	<p>&lt;Lubrication Point&gt; Inside surface of "Guide Plate, CR"</p>
	<p>&lt;Lubrication Type&gt; G-26</p>
	<p>&lt;Lubrication Amount&gt; Home position side: To edge of 'Cover, Guide Plate, CR'. Opposite side: To about 40mm from edge.</p>
	<p>&lt;Remarks&gt; Use a syringe to apply it</p>

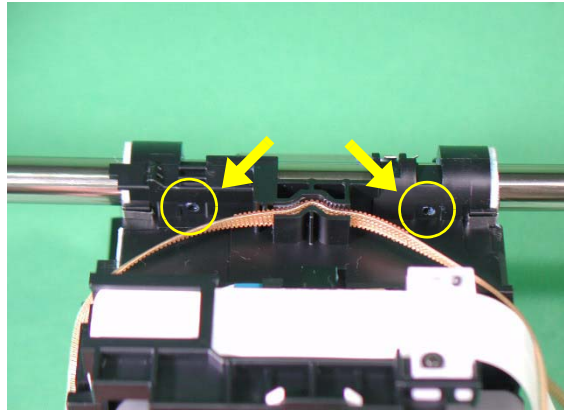
	<p>&lt;Lubrication Point&gt; Holes inside the Carriage</p>
	<p>&lt;Lubrication Type&gt; G-63</p>
	<p>&lt;Lubrication Amount&gt; 150mg-210mg x 2 points</p>
	<p>&lt;Remarks&gt; Use a syringe to apply it</p>

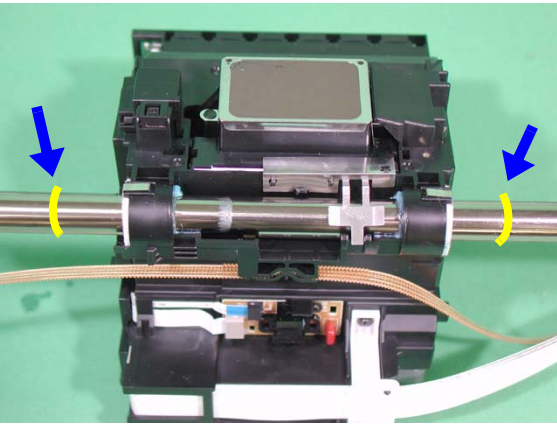
	<p>&lt;Lubrication Point&gt; "CR Guide Shaft" outside the bearing of the Carriage</p>
	<p>&lt;Lubrication Type&gt; G-63</p>
	<p>&lt;Lubrication Amount&gt; 120mg-160mg x 2 points</p>
	<p>&lt;Remarks&gt; 1. Use a syringe to apply it 2. Apply grease while rotating "CR Guide Shaft"</p>

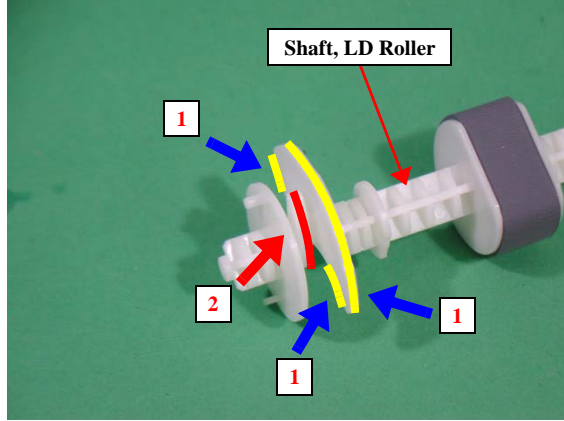
	<p>&lt;Lubrication Point&gt; 1. Cam of "Shaft, LD Roller" shown in the figure 2. Contact point between cam of "Shaft, LD Roller" and "Paper Back Lever"</p>
	<p>&lt;Lubrication Type&gt; 1. G-46 2. G-46</p>
	<p>&lt;Lubrication Amount&gt; Adequate dose</p>
	<p>&lt;Remarks&gt; Use a flux dispenser to apply it</p>

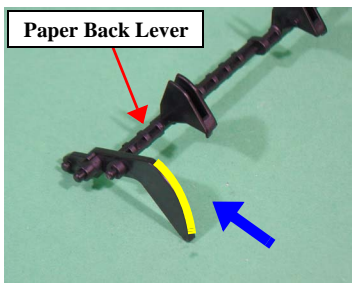
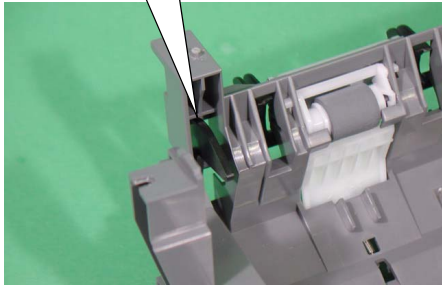
 <p>Paper Back Lever</p>	<p><b>&lt;Lubrication Point&gt;</b> Point shown in the figure of "Paper Back Lever" set in "ASF Assy."</p>
	<p><b>&lt;Lubrication Type&gt;</b> G-46</p>
	<p><b>&lt;Lubrication Amount&gt;</b> Adequate dose</p>
	<p><b>&lt;Remarks&gt;</b> Use a flux dispenser</p>

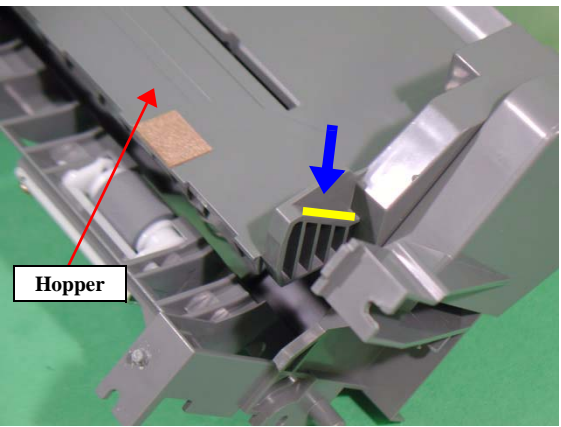
 <p>Hopper</p>	<p><b>&lt;Lubrication Point&gt;</b> Point on the right side of "Hopper" as shown in the figure</p>
	<p><b>&lt;Lubrication Type&gt;</b> G-46</p>
	<p><b>&lt;Lubrication Amount&gt;</b> Adequate dose</p>
	<p><b>&lt;Remarks&gt;</b> Use a flux dispenser to apply it</p>

**CHAPTER**

**5**

**APPENDIX**

## 5.1 Exploded Diagram

---

An exploded diagram is not provided in the Stylus R300/R310 Service Manual. If consultation of an exploded diagram is necessary, see the Exploded Diagram attached to the Stylus R300/R310 Parts List.

## 5.2 Electrical Circuits

---

The electric circuit diagrams below are shown at the following pages:

- Main Board (1) (C536MAIN)
- Main Board (2) (C536MAIN)
- Power Board (C536PSB)
- Power Board (C536PSE)
- Panel Board (C536PNL)

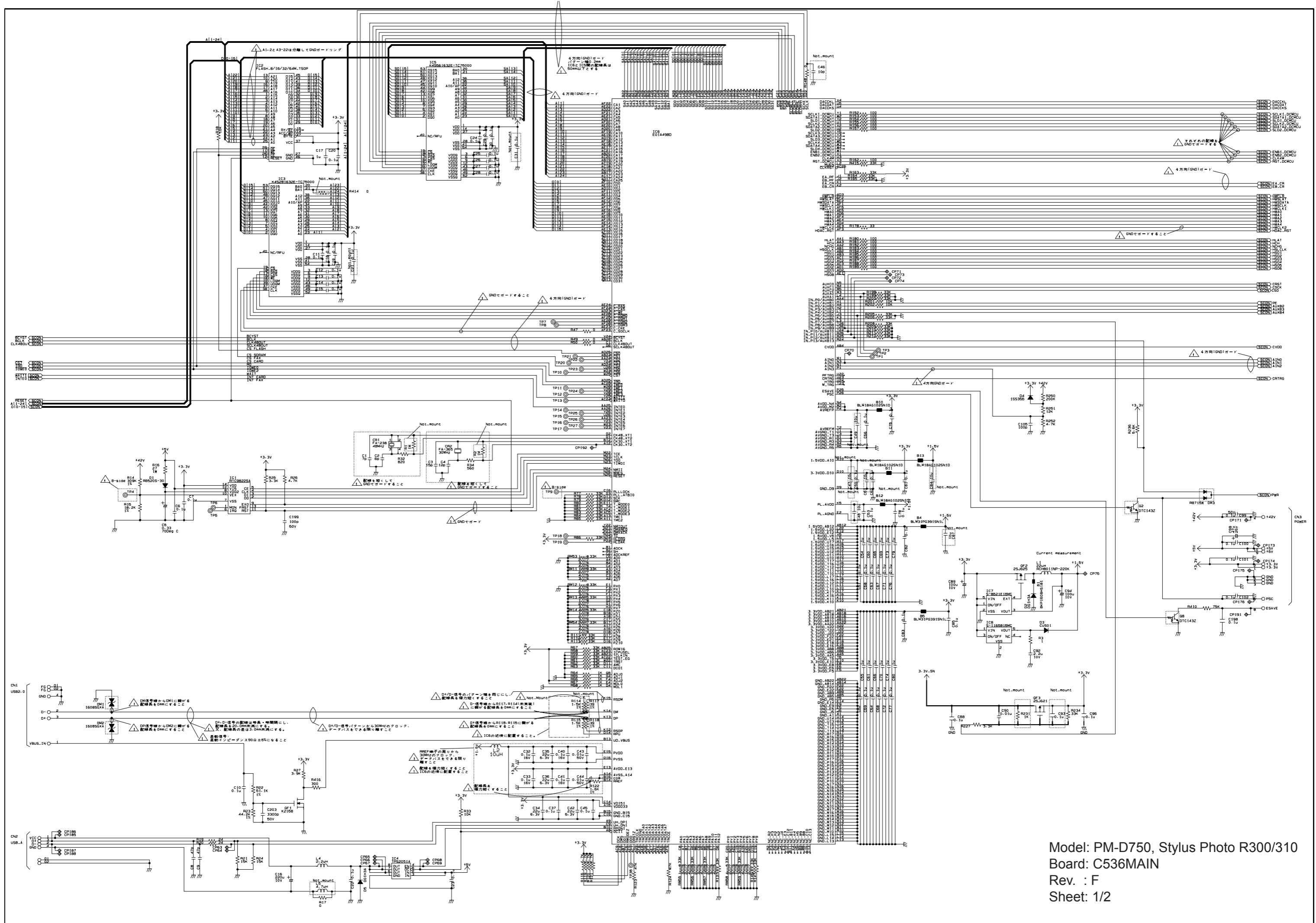

Model: PM-D750, Stylus Photo R300/310  
 Board: C536MAIN  
 Rev. : F  
 Sheet: 1/2



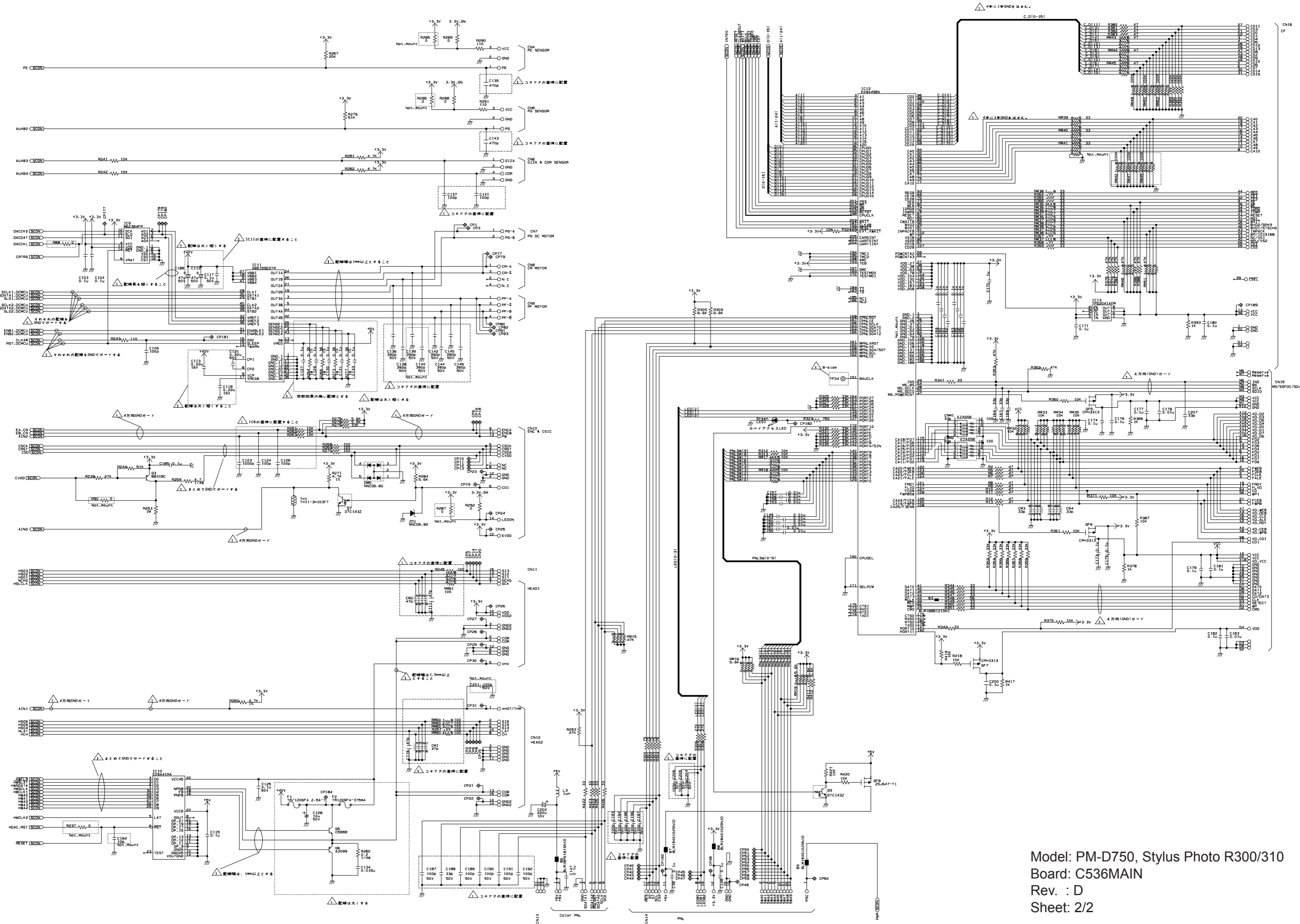

Model: PM-D750, Stylus Photo R300/310  
Board: C536MAIN  
Rev. : D  
Sheet: 2/2

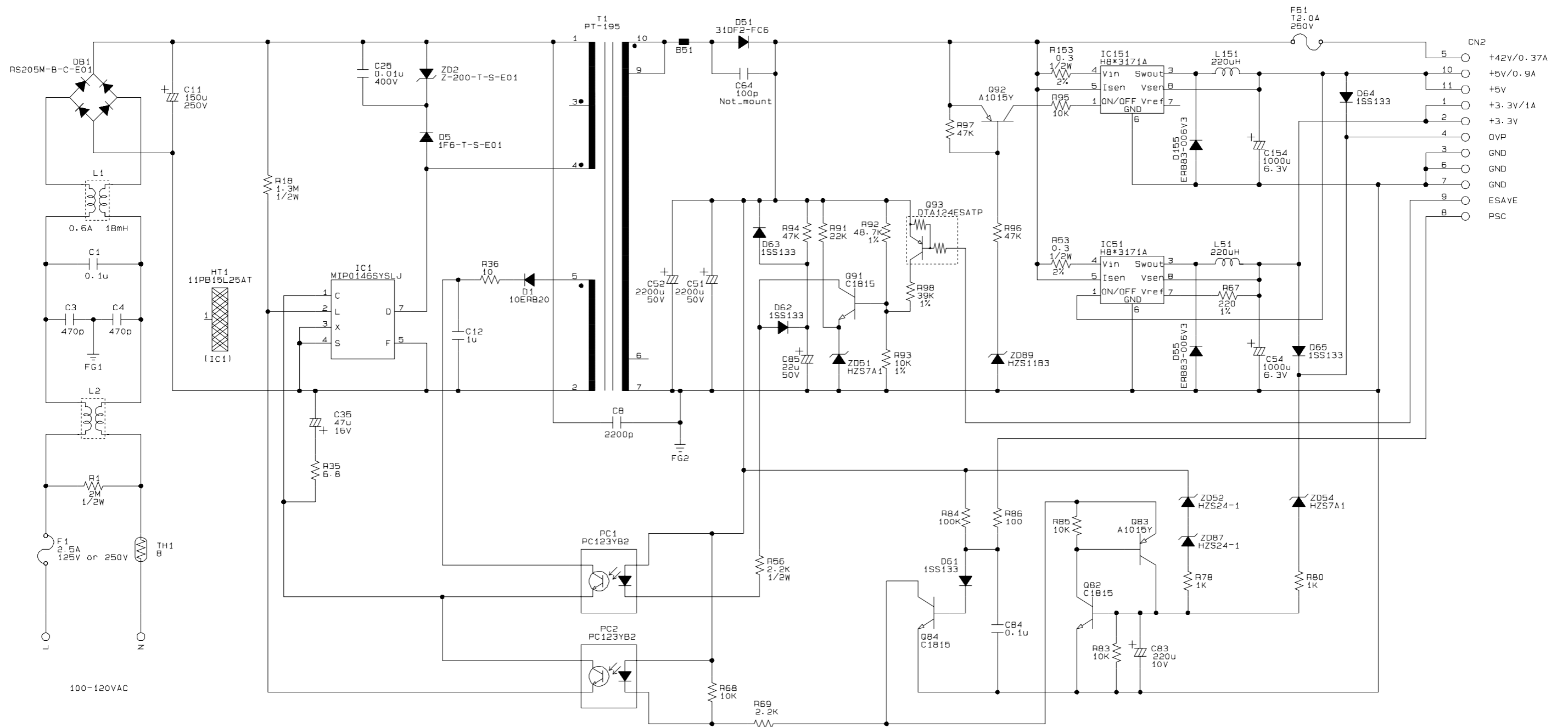

Model: PM-D750, Stylus Photo R300/310  
 Board: C536PSB  
 Rev. : C  
 Sheet: 1/1

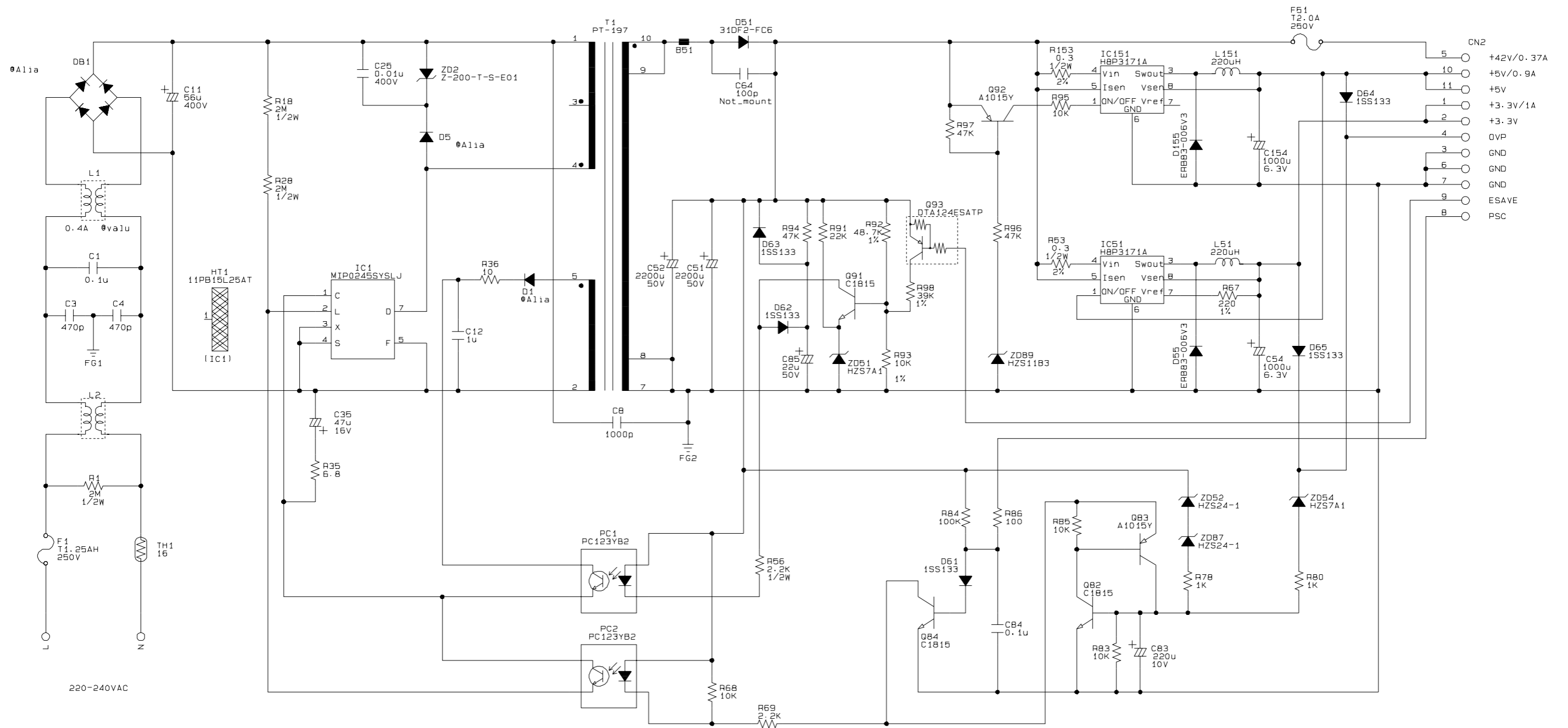

Model: Stylus Photo R300/310  
 Board: C536PSE  
 Rev. : D  
 Sheet: 1/1

CN1

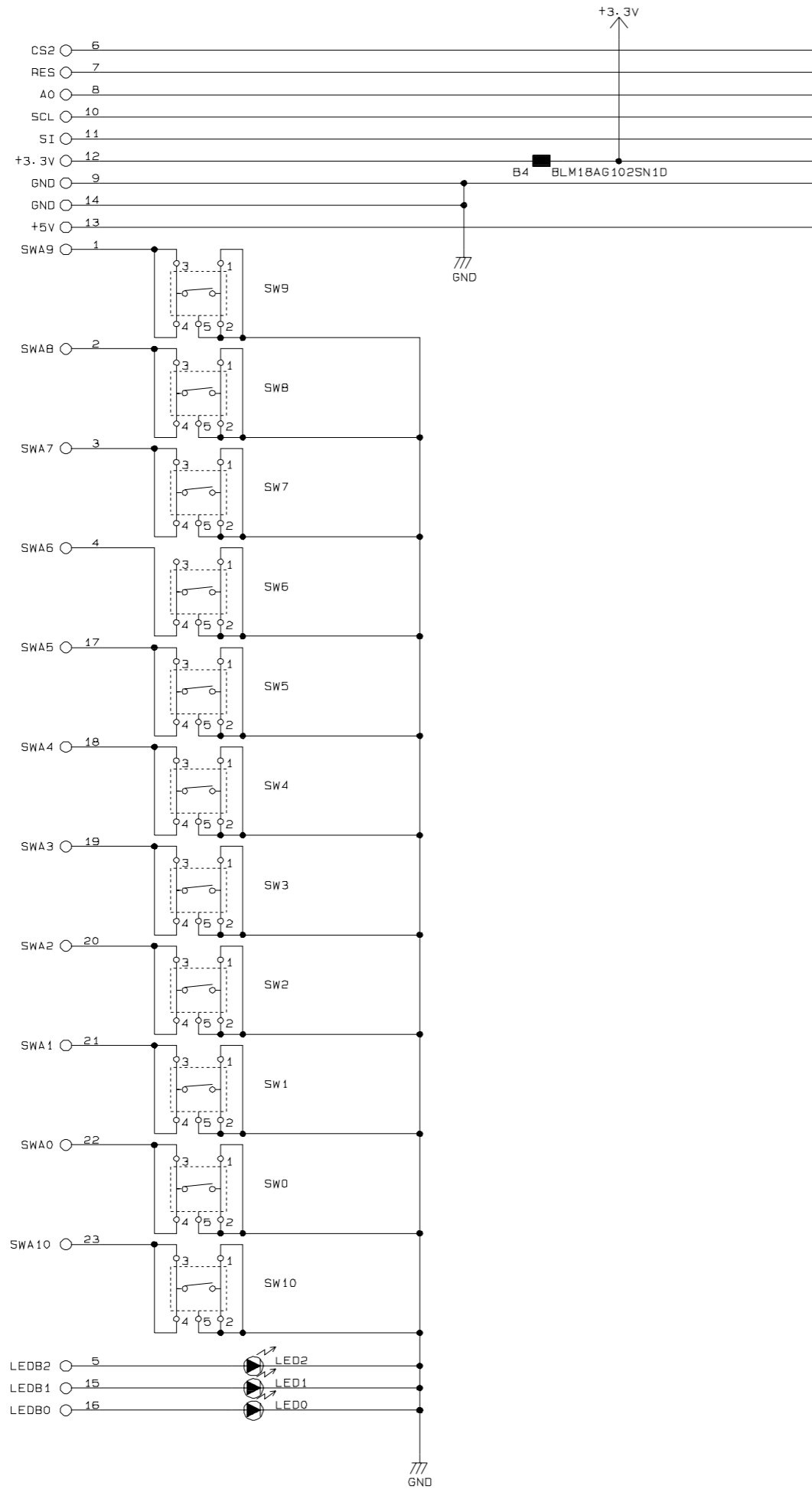

GND

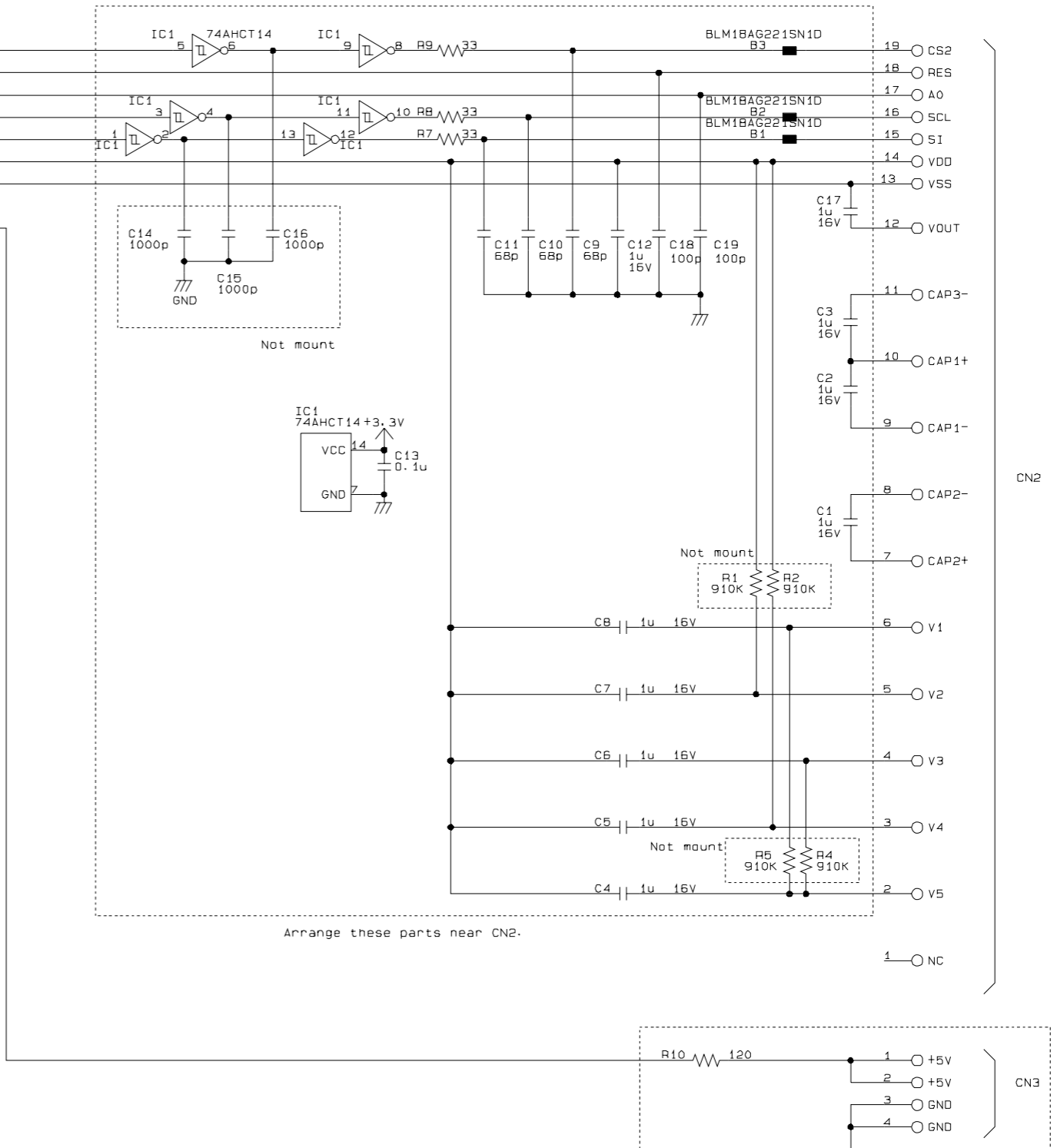

These parts are mounting when backlight is installed.

Model: PM-D750, Stylus Photo R300/310  
 Board: C536PNL  
 Rev. : C  
 Sheet: 1/1