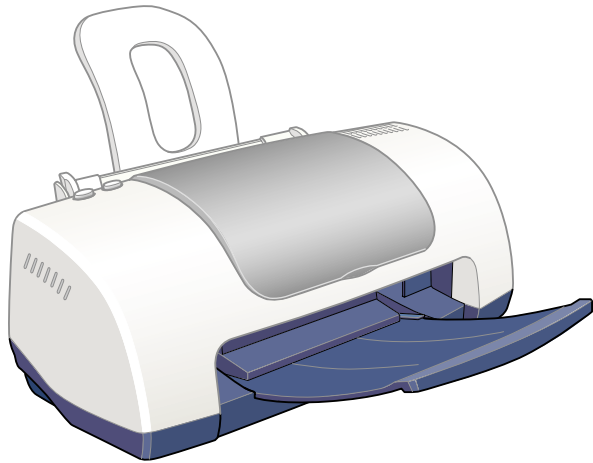


SERVICE MANUAL



Color Inkjet Printer

Stylus C40UX/C40SX/C20UX/C20SX



EPSON®

Notice

- All rights reserved. No part of this manual may be reproduced, stored in a retrieval system, or transmitted in any form or by any means electronic, mechanical, photocopying, or otherwise, without the prior written permission of SEIKO EPSON CORPORATION.
- All effort have been made to ensure the accuracy of the contents of this manual. However, should any errors be detected, SEIKO EPSON would greatly appreciate being informed of them.
- The contents of this manual are subject to change without notice.
- The above notwithstanding SEIKO EPSON CORPORATION can assume no responsibility for any errors in this manual or the consequences thereof.

EPSON is a registered trademark of SEIKO EPSON CORPORATION.

General Notice: Other product names used herein are for identification purpose only and may be trademarks or registered trademarks of their respective owners. EPSON disclaims any and all rights in those marks.

PRECAUTIONS

Precautionary notations throughout the text are categorized relative to 1) Personal injury and 2) damage to equipment.

DANGER Signals a precaution which, if ignored, could result in serious or fatal personal injury. Great caution should be exercised in performing procedures preceded by DANGER Headings.

WARNING Signals a precaution which, if ignored, could result in damage to equipment.

The precautionary measures itemized below should always be observed when performing repair/maintenance procedures.

DANGER

1. ALWAYS DISCONNECT THE PRODUCT FROM THE POWER SOURCE AND PERIPHERAL DEVICES PERFORMING ANY MAINTENANCE OR REPAIR PROCEDURES.
2. NO WORK SHOULD BE PERFORMED ON THE UNIT BY PERSONS UNFAMILIAR WITH BASIC SAFETY MEASURES AS DICTATED FOR ALL ELECTRONICS TECHNICIANS IN THEIR LINE OF WORK.
3. WHEN PERFORMING TESTING AS DICTATED WITHIN THIS MANUAL, DO NOT CONNECT THE UNIT TO A POWER SOURCE UNTIL INSTRUCTED TO DO SO. WHEN THE POWER SUPPLY CABLE MUST BE CONNECTED, USE EXTREME CAUTION IN WORKING ON POWER SUPPLY AND OTHER ELECTRONIC COMPONENTS.
4. WHEN DISASSEMBLING OR ASSEMBLING A PRODUCT, MAKE SURE TO WEAR GLOVES TO AVOID INJURIES FROM METAL PARTS WITH SHARP EDGES.

WARNING

1. REPAIRS ON EPSON PRODUCT SHOULD BE PERFORMED ONLY BY AN EPSON CERTIFIED REPAIR TECHNICIAN.
2. MAKE CERTAIN THAT THE SOURCE VOLTAGE IS THE SAME AS THE RATED VOLTAGE, LISTED ON THE SERIAL NUMBER/RATING PLATE. IF THE EPSON PRODUCT HAS A PRIMARY AC RATING DIFFERENT FROM AVAILABLE POWER SOURCE, DO NOT CONNECT IT TO THE POWER SOURCE.
3. ALWAYS VERIFY THAT THE EPSON PRODUCT HAS BEEN DISCONNECTED FROM THE POWER SOURCE BEFORE REMOVING OR REPLACING PRINTED CIRCUIT BOARDS AND/OR INDIVIDUAL CHIPS.
4. IN ORDER TO PROTECT SENSITIVE MICROPROCESSORS AND CIRCUITRY, USE STATIC DISCHARGE EQUIPMENT, SUCH AS ANTI-STATIC WRIST STRAPS, WHEN ACCESSING INTERNAL COMPONENTS.
5. DO NOT REPLACE IMPERFECTLY FUNCTIONING COMPONENTS WITH COMPONENTS WHICH ARE NOT MANUFACTURED BY EPSON. IF SECOND SOURCE IC OR OTHER COMPONENTS WHICH HAVE NOT BEEN APPROVED ARE USED, THEY COULD CAUSE DAMAGE TO THE EPSON PRODUCT, OR COULD VOID THE WARRANTY OFFERED BY EPSON.

About This Manual

This manual describes basic functions, theory of electrical and mechanical operations, maintenance and repair procedures of the printer. The instructions and procedures included herein are intended for the experienced repair technicians, and attention should be given to the precautions on the preceding page.

Manual Configuration

This manual consists of six chapters and Appendix.

CHAPTER 1. PRODUCT DESCRIPTIONS

Provides a general overview and specifications of the product.

CHAPTER 2. OPERATING PRINCIPLES

Describes the theory of electrical and mechanical operations of the product.

CHAPTER 3. TROUBLESHOOTING

Describes the step-by-step procedures for the troubleshooting.

CHAPTER 4. DISASSEMBLY / ASSEMBLY

Describes the step-by-step procedures for disassembling and assembling the product.

CHAPTER 5. ADJUSTMENT

Provides Epson-approved methods for adjustment.

CHAPTER 6. MAINTENANCE

Provides preventive maintenance procedures and the lists of Epson-approved lubricants and adhesives required for servicing the product.

APPENDIX Provides the following additional information for reference:

- Connector pin assignments
- Electric circuit boards components layout
- Electrical circuit boards schematics
- Exploded diagram & Parts List

Symbols Used in this Manual

Various symbols are used throughout this manual either to provide additional information on a specific topic or to warn of possible danger present during a procedure or an action. Be aware of all symbols when they are used, and always read NOTE, CAUTION, or WARNING messages.



Indicates an operating or maintenance procedure, practice or condition that is necessary to keep the product's quality.



Indicates an operating or maintenance procedure, practice, or condition that, if not strictly observed, could result in damage to, or destruction of, equipment.



May indicate an operating or maintenance procedure, practice or condition that is necessary to accomplish a task efficiently. It may also provide additional information that is related to a specific subject, or comment on the results achieved through a previous action.



Indicates an operating or maintenance procedure, practice or condition that, if not strictly observed, could result in injury or loss of life.



Indicates that a particular task must be carried out according to a certain standard after disassembly and before re-assembly, otherwise the quality of the components in question may be adversely affected.

Revision Status

Revision	Issued Date	Description
A	May 31. 2001	First Release

CONTENTS

Chapter 1 PRODUCT DESCRIPTION

1.1 FEATURES	9
1.2 Differences between the Stylus C20 and the Stylus C40	9
1.3 SECIFICATIONS	10
1.3.1 Physical Specification	10
1.3.2 Printing Specification	10
1.3.3 Paper Feeding	11
1.3.4 Input Data Buffer	11
1.3.5 Electrical specification	11
1.3.6 Envirornental Condition	12
1.3.7 Reliability	12
1.3.8 Safety Approvals	12
1.3.9 Acoustic Noise	12
1.3.10 CE Marking	12
1.4 INTERFACE	13
1.4.1 USB Interface	13
1.4.2 Parallel Interface (Forward Channel)	13
1.4.3 Parallel Interface (Reverse Channel)	15
1.4.4 Prevention Hosts from Data Transfer Time-out	16
1.4.5 IEEE1284.4 Protocol	17
1.5 OPERATOR CONTROLS	18
1.5.1 Operate Switch	18
1.5.2 Control Panel	18
1.5.3 Panel Functions	18
1.5.4 Printer Condition and Panel Status	18
1.5.5 Printer Initialization	19
1.5.6 Errors	19
1.6 PAPER	20
1.6.1 Paper Handling	20
1.6.2 Paper Specification	20
1.6.3 Printing Area	21

1.7 INK CARTRIDGE	23
1.7.1 Black Ink Cartridge	23
1.7.2 Color Ink Cartridge	23

Chapter 2 Operating Principles

2.1 Overview	25
2.1.1 Printer Mechanism	25
2.1.2 Printhead	26
2.1.2.1 Printing Process	27
2.1.2.2 Printing Method	27
2.1.3 Carriage Mechanism	28
2.1.4 Paper Feeding Mechanism	30
2.1.5 Paper Loading Mechanism (ASF Unit)	31
2.1.6 Ink System Mechanism	35
2.1.6.1 Pump Unit & Wiper mechanism	35
2.1.6.2 Capping Mechanism	36
2.1.7 Ink Sequence	38
2.1.8 Printing mode	40
2.2 Electrical Circuit Operating Principles	41
2.2.1 C417 PSB/PSE board	41
2.2.2 C413 MAIN/B Board	43
2.2.2.1 Main elements	43

Chapter 3 Troubleshooting

3.1 Overview	45
3.2 Troubleshooting with LED Error Indications	46

Chapter 4 Disassembly and Assembly

4.1 Overview	57
4.1.1 Precautions	57

4.1.2 Tools	59
4.1.3 Screws	59
4.1.4 Work Completion Check	60
4.2 Disassembly	61
4.2.1 Upper housing removal	62
4.2.2 ASF unit removal	63
4.2.3 Waste ink pad removal	64
4.2.4 PS unit removal	65
4.2.5 Paper eject roller removal	66
4.2.6 MAIN board removal	68
4.2.7 CR motor removal	70
4.2.8 Printhead unit removal	71
4.2.9 LD unit removal	73
4.2.10 Printer mechanism removal	74

Chapter 5 Adjustment

5.1 Overview	76
5.1.1 Required Adjustment	76
5.1.2 Adjustment Program Initial Setting menu	77
5.1.3 Adjustment Program feature	78
5.1.4 EEPROM initial setting	80
5.1.5 Head ID	80
5.1.6 Bi-D	82
5.1.7 USB ID	83
5.1.8 Top margin	85
5.1.9 Head cleaning	86
5.1.10 Initial ink charge	86
5.1.11 Refurbishment for DOA	87
5.1.12 Protection counter check	88
5.1.13 EEPROM check	90
5.1.14 EEPROM back up data	91
5.1.15 A4 pattern will print	92

Chapter 6 Maintenance

6.1 Overview	95
6.1.1 Cleaning	95
6.1.2 Service Maintenance	96
6.1.3 Lubrication	96

Chapter 7 Appendix

7.1 Connector Summary	100
7.1.1 Major Component Unit	100
7.2 EEPROM Address Map	102
7.3 Component Layout	106
7.4 Parts List	108
7.5 Exploded Diagram	109
7.6 Electrical Circuits	115

CHAPTER

1

PRODUCT DESCRIPTION

1.1 FEATURES

- High color print quality
 - 1440 (H) x 720 (V) dpi printing
 - 4 color printing (YMCK)
 - Traditional and New Microweave
- Built-in auto sheet feeder
 - Holds 100 cut-sheets (65 g/m²)
 - Holds 10 envelopes
 - Holds 10 transparency films
- Built-in I/F

Interface specification for each model are as the following.

Parallel Interface .EPSON Stylus C40SX .EPSON Stylus C20SX

USB Interface .EPSON Stylus C40UX .EPSON Stylus C20UX
- Windows / Macintosh exclusive

1.2 Differences between the Stylus C20 and the Stylus C40

The Stylus C20 and Stylus C40 are mechanically the same, but the throughput of the Stylus C40 is slightly higher than that of the Stylus C20. (Refer to Table 1-1.)

Table 1-1. Throughput

Models	memo economy	Normal
Stylus C20	6.5 PPM	3.0 PPM
Stylus C40	8.0 PPM	3.5 PPM

In both models, demarcation is determined by the EEPROM value 29 <H>. When the value of bit 0 is 1, a wait of 40

msec is inserted for each CR pass during printing, then the next operation starts.

Table 1-2. Delay of operation

EEPROM 29 <H> bit 0 value	Model	Delay time during printing
0	Stylus C40	None
1	Stylus C20	CR 40 msec for each pass.

1.3 SECIFICATIONS

This section covers specifications of the printer.

1.3.1 Physical Specification

- Weight : 2.48kg (without the ink cartridges)
- Dimension : 424 mm(W) x 227 mm (D) x 168 mm (H) (Printing)

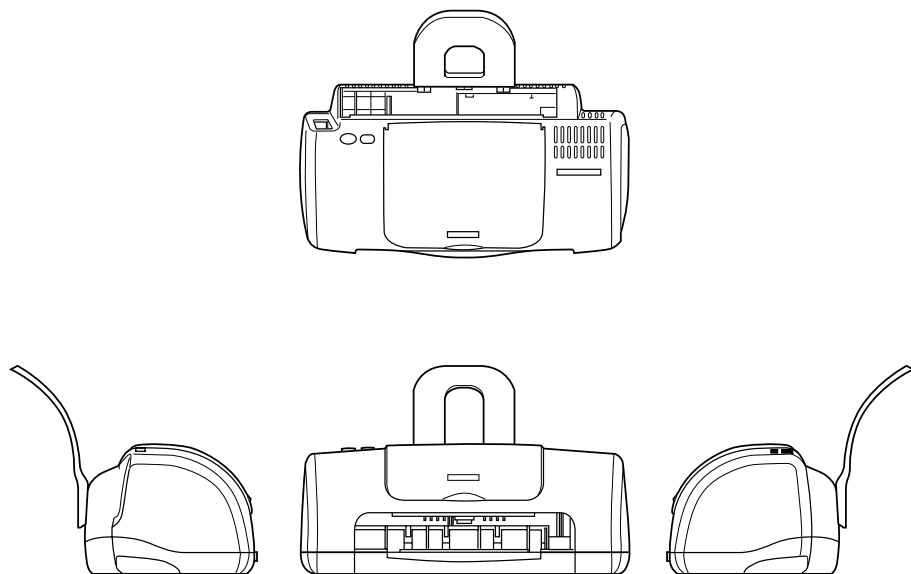


Figure 1-1. Stylus C40/C20 Dimensions

1.3.2 Printing Specification

- Print method : On demand ink jet
- Nozzle Configuration : monochrome 48 nozzles
: color 15 nozzles x 3 (Cyan, Magenta, Yellow)
- Print direction : Bi-direction with logic seeking
- Print speed & Printable columns
Character mode : Black only

Character Pitch	Character Quality	Printable Columns	CR Speed
10CPI	LQ	80 Columns	20IPS

Raster graphics mode

Horizontal resolution	Printable area	Available dot	CR Speed	Notes
480 dpi	8.26 inch	3968	14.1 IPS	Black mode
360 dpi	8.26 inch	2976	23.8 IPS	-
720 dpi	8.26 inch	5952	20 IPS	-
1440 dpi	8.26 inch	11904	20 IPS	-

- Control code* : ESC/P R4C7050 exclusive
: EPSON Remote command
- Character tables* : none
ASCII 20h to 7Fh code support.
- Typeface*
 - Bit map LQ font :EPSON Courier 10 CPI
 - International character sets * : None

* Do not mention to the user's manual about control code, character table, typeface and International character sets.

1.3.3 Paper Feeding

- Feeding method : Friction feed with ASF
- Paper path : Cut-sheet ASF (Top entry)
- Feed speed :

Feed condition	Time	Speed
10.16mm(0.4 inch) feed	110msec	92.36mm (3.64inch)/sec
Continuous feed	140msec	139.7mm (5.5inch)/sec

1.3.4 Input Data Buffer

- Buffer size :12 Kbytes

1.3.5 Electrical specification

- 120 V version
 - Rated voltage : AC 120 V
 - Input voltage range : AC 99 - 132 V
 - Rated frequency range : 50 - 60 Hz
 - Input frequency range : 49.5 - 60.5 Hz
 - Rated current : 0.4A
 - Power consumption : Approx. 16W (ISO/IEC 10561 Letter pattern)
: Approx. 4W in standby mode
: Energy Star compliant
 - Insulation Resistance :10 M ohms min.
(between AC line and chassis, DC 500 V)
 - Dielectric strength : AC 1000 V rms. 1 minute or
AC 1200 V rms. 1 second
(between AC line and chassis)
- 220-240 V version
 - Rated voltage : AC 220 - 240 V
 - Input voltage range : AC 198 - 264 V
 - Rated frequency range : 50 - 60 Hz
 - Input frequency range : 49.5 - 60.5 Hz
 - Rated current : 0.2A
 - Power consumption : Approx. 16W (ISO/IEC 10561 Letter pattern)
: Approx. 4W in standby mode
: Energy Star compliant
 - Insulation Resistance :10 M ohms min.
(between AC line and chassis, DC 500 V)
 - Dielectric strength : AC 1500 V rms. 1 minute
(between AC line and chassis)

1.3.6 Environmental Condition

- Temperature : 10 to 35 °C (operating *3)
: -20 to 60 °C(non-operating, *1)
1 month at 40 °C
120 hours at 60 °C
- Humidity : 20 to 80% RH (operating, *2,*3)
: 5 to 85% RH (non-operating, *1, *2)
- Resistance to shock : 1 G, within 1 ms (operating)
: 2 G, within 2 ms (non-operating, *1)
- Resistance to vibration : 0.15G (operating)
: 0.50G (non-operating, *1)

*1: with shipment container

*2: without condensation

*3: Condition is as following figure.

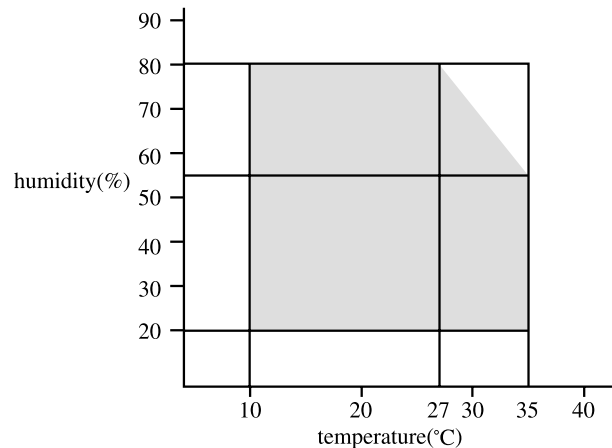


Figure 1-2. Environmental Condition

1.3.7 Reliability

- Total print volume : 10,000 pages (A4, Letter) or
20,000 pages (A4, Letter)
*refer to “EEPROM Address Map” on page -102
- Print Head Life : 4000 million dots/nozzle

1.3.8 Safety Approvals

- 120 V version :
Safety standards : UL1950 with D3
CSA C22.2 No.950 with D3
EMI : FCC part15 subpart B class B
CSA C108.8 class B
- 220-240 V version :
Safety standards : EN 60950(VDE)
EMI : EN 55022(CISPR Pub.22) class B
: AS/NZS 3548 class B

1.3.9 Acoustic Noise

- Level : Approx. 45 dB(A) (According to ISO 7779)

1.3.10 CE Marking

- 220-240 V version
Low Voltage Directive 73/23/EEC : EN60950
EMC Directive 89/336/EEC : EN55022 Class B
EN61000-3-2
EN61000-3-3
EN50082-1
IEC801-2
IEC801-3
IEC801-4

1.4 INTERFACE

Interface specification for each model are as the following.

Parallel Interface :EPSON Stylus C40SX .EPSON Stylus C20SX

USB Interface :EPSON Stylus C40UX .EPSON Stylus C20UX

*This printer interface as standard.

1.4.1 USB Interface

- Standard : based on
 “Universal Serial Bus Specifications Revision 1.1”
 “Universal Serial Bus Device Class Definition for Printing Devices Version 1.1”
- Bit rate : 12Mbps (Full Speed Device)
- Data encoding : NRZI
- Adaptable connector : USB Series B
- Recommended cable length : 2 meters

Connect er pin assinment and signals:

Pin No.	Signal name	In/Out	Function description
1	VCC	-	Cable power. Maximum power consumption is 100mA
2	Data	bi-directional	Data
3	+Data	bi-directiona	data, pull up to +3.3V via 1.5K ohm resistor
4	Ground	-	Cable ground

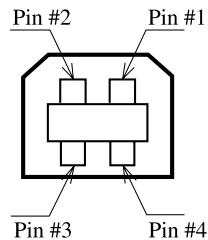


Figure 1-3. USB Pin Assignment

1.4.2 Parallel Interface (Forward Channel)

- Transmission mode : 8 bit parallel, IEEE-1284 compatibility mode
- Synchronization : By STROBE pulse
- Handshaking : By BUSY and ACKNLG signal
- Signal level : TTL compatible level
- Adaptable connector : 57-30360(amphenol) or equivalent

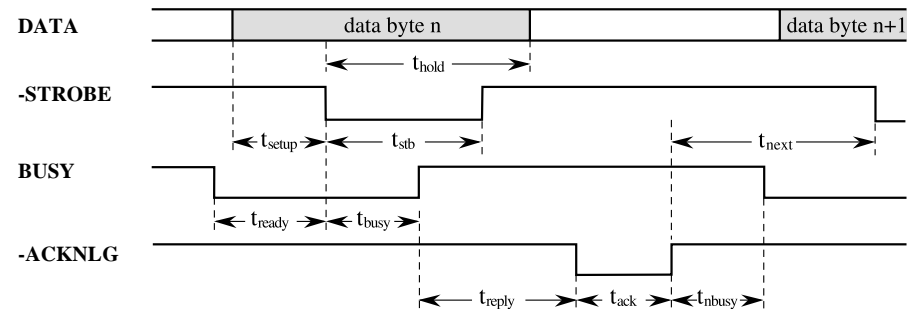
BUSY signal is set high before setting either -ERROR low or PE high and held high until all these signals return to their inactive state.

- BUSY signal is at high level in the following cases.
- During data entry (see Data transmission timing)
 - When input data buffer is full
 - During -INIT signal is at low level or during hardware initialization
 - During printer error (See -ERROR signal)

- ERROR signal is at low level when the printer is in one of the following states.
- Printer hardware error (fatal error)
 - Paper-out error
 - Paper-jam error
 - Ink-out error
 - Ink overflow error

PE signal is at high level during paper-out error.

Data transmission timing :



Parameter	Minimum	Maximum
tsetup	500 ns	-
thold	500 ns	-
tstb	500 ns	-
tready	0	-
tbusy	-	500 ns
tt-out*	-	120 ns
tt-in**	-	200 ns

Parameter	Minimum	Maximum
treply	0	-
tack	500 ns	10 us
tnbusy	0	-
tnext	0	-

* Rise and fall time of every output signals

** Rise and fall time of every input signals

***Typical time of tack is shown below.

Parallel I/F mode	typical time of tack
High speed	2us
Normal speed	4usror

Signal level : TTL compatible (IEEE-1284 level 1 device)

Parameter	Minimum	Maximum	Condition
VOH*	-	5.5 V	
is.			
VOL*	-0.5 V	-	
IOH*	-	0.32 mA	VOH = 2.4 V
IOL*	-	12 mA	VOL = 0.4 V
CO	-	50 pF	
VIH	-	2.0 V	
VIL	0.8V	-	
IIH	-	0.32 mA	VIH = 2.0 V
IIL	-	12 mA	VIL = 0.8 V
CI	-	50 pF	

* A low logic level on the Logic H signal is. 2.0 V or less when the printer is powered off and this signal is equal or exceeding 3.0V when the printer is powered on. The receiver shall provide an impedance equivalent to 7.5 K ohm to ground

Connector pin assignment and signals :

Pin No.	Signal Name Return	GND pin	In/Out	Functional description
1	-STROBE	19	In	The strobe pulse. Read-in of data is performed at the falling edge of this pulse.
2	DATA0	20	In	The DATA0 through DATA7 signals represent data bits 0 to 7, respectively. Each signal is at high level when data is logical 1 and low level when data is logical 0.
3	DATA1	21	In	
4	DATA2	22	In	
5	DATA3	23	In	
6	DATA4	24	In	
7	DATA5	25	In	
8	DATA6	26	In	
9	DATA7	27	In	
10	-ACKNLG	28	Out	This signal is a negative pulse indicating that the printer can again accept data.
11	BUSY	29	Out	A high signal indicates that the printer cannot receive data.
12	PE	28	Out	A high signal indicates paper-out error.
13	SLCT	28	Out	Always at high level when the printer is powered on.
14	-AFXT	30	In	Not used.
31	-INIT	30	In	The falling edge of a negative pulse or a low signal on this line causes the printer to initialize. Minimum 50 us pulse is necessary.
32	-ERROR	29	Out	A low signal indicates printer error condition.
36	-SLIN	30	In	Not used.
18	Logic H	-	Out	Pulled up to +5 V via 3.9 K ohm resistor.
35	+5V	-	Out	Pulled up to +5 V via 3.3 K ohm resistor.

Pin No.	Signal Name Return	GND pin	In/Out	Functional description
17	Chassis GND	-	-	Chassis GND.
16, 33 19-30	GND	-	-	Signal GND.
15, 34	NC	-	-	Not connected.

* In/Out refers to the direction of signal flow from the printer's point of view.

1.4.3 Parallel Interface (Reverse Channel)

Transmission mode	: IEEE-1284 nibble mode
Adaptable connector	: See forward channel
Synchronization	: Refer to the IEEE-1284 specification
Handshaking	: Refer to the IEEE-1284 specification
Data trans. timing	: Refer to the IEEE-1284 specification
Signal level	: IEEE-1284 level 1 device See forward channel

Connector pin assignment and signals :

Pin No.	Signal Name	ReturnG ND Pin	In/ Out*	Functional description
1	HostClk	19	In	Host clock signal.

Pin No.	Signal Name	ReturnG ND Pin	In/ Out*	Functional description
2	DATA0	20	In	The DATA0 through DATA7 signals represent data bits 0 to 7, respectively. Each signal is at high level when data is logical 1 and low level when data is logical 0. These signals are used to transfer the 1284 extensibility request values to the printer.
3	DATA1	21	In	
4	DATA2	22	In	
5	DATA3	23	In	
6	DATA4	24	In	
7	DATA5	25	In	
8	DATA6	26	In	
9	DATA7	27	In	
10	PtrClk	28	Out	Printer clock signal.
11	PtrBusy / DataBit-3,7	29	Out	Printer busy signal and reverse channel transfer data bit 3 or 7.
12	AckDataReq/ DataBit-2,6	28	Out	Acknowledge data request signal and reverse channel transfer data bit 2 or 6.
13	Xflag / DataBit-1,5	28	Out	X-flag signal and reverse channel transfer data bit 1 or 5.
14	HostBusy	30	In	Host busy signal.
31	-INIT	30	In	Not used.
32	-DataAvail / DataBit-0,4	29	Out	Data available signal and reverse channel transfer data bit 0 or 4.
36	1284-Active	30	In	1284 active signal.
18	Logic-H	-	Out	Pulled up to +5 V via 3.9 K ohm resistor.
35	+5V	-	Out	Pulled up to +5 V via 3.3 K ohm resistor.
17	Chassis GND	-	-	Chassis GND.
16, 33 19-30	GND	-	-	Signal GND.
15, 34	NC	-	-	Not connected.

* In/Out refers to the direction of signal flow from the printer's point of view.

Extensibility Request :

The printer responds affirmatively when the extensibility request values are 00H or 04H, that mean,

- 00H : Request Nibble Mode Reverse Channel Transfer.
- 04H : Request Device ID;
Return Data Using Nibble Mode Rev Channel Transfer.

Device ID :

The printer sends following device ID string when it is requested.

```
When IEEE1284.4 is enabled,
  [00H] [4EH]
  MFG:EPSON;
  CMD:ESCPL2,BDC,D4;
  MDL:Stylus[SP]XXX;

CLS:PRINTER;
DES:EPSON[SP]Stylus[SP]XXX;
When IEEE1284.4 is disabled,
  [00H] [4BH]
  MFG:EPSON;
  CMD:ESCPL2,BDC;
  MDL:Stylus[SP]XXX;
CLS:PRINTER;
DES:EPSON[SP]Stylus[SP]XXX;
```

*XXX is C20 or C40

- Note : (1) [00H] denotes a hexadecimal value of zero.
 (2) MDL value depends on the EEPROM setting. Refer to Appendix F.
 (3) CMD value depends on the IEEE1284.4 setting, Refer to Appendix F.

1.4.4 Prevention Hosts from Data Transfer Time-out

Generally, hosts abandon data transfer to peripherals when a peripheral is in the busy state for dozens of seconds continuously. To prevent hosts from this kind of time-out, the printer receives data very slowly, several bytes per minute, even if the printer is in

busy state. This slowdown is started when the rest of the input buffer becomes several hundreds of bytes. Finally, the printer is in the busy state continuously when the input buffer is full.

1.4.5 IEEE1284.4 Protocol

The packet protocol described by IEEE1284.4 standard allows a device to carry on multiple exchanges or conversations which contain data and/or control information with another device at the same time across a single point-to-point link. The protocol is not, however, a device control language. It does provide basic transport-level flow control and multiplexing services. The multiplexed logical channels are independent of each other and blocking of one has no effect on the others. The protocol operate over IEEE1284.

- Automatic selection

An initial state is compatible interface and starts IEEE1284.4 communication when magic strings (IEEE 1284.4 synchronous commands) are received.

- On

An initial state is IEEE1284.4 communication and data that received it by the time it is able to take synchronization by magic string (IEEE 1284.4 synchronous commands) is discarded.

- Off

An initial state is compatible interface and never starts IEEE1284.4 communication even if magic strings (IEEE 1284.4 synchronous commands) are received.

Factory setting is on.(Refer to Appendix H.EEPROM Map 09h)

1.5 OPERATOR CONTROLS

1.5.1 Operate Switch

Operate switch is located on the control panel.

1.5.2 Control Panel

□ Switches

There are 2 non-lock type push switches, and 2 LED.

□ Indicators

(1) Power (green)

Lights when the operate switch is "ON", and AC power is supplied.

(2) Error (red)

Lights or blinks when some error occurs to the printer.

1.5.3 Panel Functions

□ Panel Functions

SW	Function
Error Reset SW	<ul style="list-style-type: none"> • Loads or Ejects the Paper(Pushing within 3seconds). • Starts the Cleaning of head(Pushing for 3seconds) • When carriage is on the Ink Cartridge change position, return carriage from Ink Cartridge change position. • Starts the Ink Cartridge change (Pushing for 6seconds)

*This function is not available in printing status.

□ Panel Function with Power on

SW	Function
Error Reset SW	Starts status printings

1.5.4 Printer Condition and Panel Status

Printer status	Indicators		
	Powe	Error	Priority
Power ON condition	On	-	10
Ink sequence	Blink	-	6
Ink Cartridge change mode	Blink	-	5
Data processing	Blink	-	9
Paper Out *1	-	On	4
Paper jam condition*1	-	On 3	3
Ink end(Black)*1	-	On->On	8
Ink level low(Black)	-	Blink->Blink	8
Ink end(Color)*1	-	On->On	8
Ink level low(Color)	-	Blink->Blink	8
Ink end (Black and Color)	-	On->On	8
No Ink Cartridge (Black or Color)*1	-	On	7
Maintenance request (Ink Overflow Counter error)	Alt blink	Alt blink	2
Fatal error*1	Off	On	1

“-”:Indicator status don't change

“a->b”:a is a Indicator condition when carriage is on Home Position.
b is a Indicator condition in Ink exchange sequence.

*1 : see

1.5.5 Printer Initialization

There are three kinds of initialization method.

(1) Power-on initialization

This printer is initialized when turning the printer power on, or printer recognized the cold-reset command (remote RS command).

When printer is initialized, following action is performed.

- (a) Initializes printer mechanism.
- (b) Clears input data buffer.
- (c) Clears print buffer.
- (d) Sets default values.

(2) Operator initialization

This printer is initialized when printer recognized the -INIT signal (negative pulse) of parallel interface.

When printer is initialized, following action is performed.

- (a) Cap the print head.
- (b) Eject a paper.
- (c) Clears input data buffer.
- (d) Clears print buffer.
- (e) Sets default values.

(3) Software initialization

The ESC @ command also initializes the printer.

When printer is initialized, following action is performed.

- (a) Clears print buffer.
- (b) Sets default values.

(4) Power-on initialization except I/F

The printer recognized the IEEE 1284.4 “rs” command.

When printer is initialized, following action is performed.

- (a) Initializes printer mechanism.
- (b) Clears input data buffer.
- (c) Clears print buffer.
- (d) Sets default values except I/F.

1.5.6 Errors

Ink out

When the printer runs out the most part of the ink of any one color, it warns ink-low and keeps printing. When the printer runs out the whole ink of any one color, it stops printing and indicates ink-out error. User is requested to install a new ink-cartridge in this state.

Paper out

When printer fails to load a sheet, it goes paper out error.

Paper jam

When printer fails to eject a sheet, it goes paper jam error.

No ink-cartridge

When printer detects that ink-cartridge comes off , it goes this error mode.

Maintenance request

When the total quantity of ink wasted through the cleanings and flushing is reaches to the limit, printer indicates this error and stops. The absorber in the printer enclosure is needed to be replaced with new one by a service person.

Fatal errors

Carriage control error.

* panel status is described on section 1.4.4.

1.6 PAPER

1.6.1 Paper Handling

Do not perform reverse feed more than 0 mm(0").

1.6.2 Paper Specification

□ Cut Sheet

Size : A4 (Width 210 mm(8.3") x Length 297 mm(11.7"))
 : Letter (Width 215.9 mm(8.5") x Length 279.4 mm(11.0"))
 : B5 (Width 182 mm(7.2") x Length 257 mm(10.1"))
 : Legal (Width 215.9 mm(8.5") x Length 355.6 mm(14.0"))
 : Half Letter (Width 139.7 mm(5.5") x Length 215.9 mm(8.5"))
 : Exclusive (Width 184.2 mm(7.5") x Length 266.7 mm(10"))
 : A5 (Width 148 mm(5.8") x Length 210 mm(8.3"))
 : A6 (Width 105 mm(4.1") x Length 210 mm(8.3"))

Thickness : 0.08 mm(0.003") - 0.11 mm(0.004")

Weight : 64 g/m 2 (17 lb.55Kg) - 90 g/m 2 (24 lb.78Kg)

Quality : Exclusive paper, Bond paper, PPC

□ Envelope

Size : No.10 Width 241 mm(9 1/2") x Length 104.8 mm(4 1/8")
 : DL Width 220 mm(8.7") x Length 110 mm(4.3")
 : C6 Width 162 mm(6.4") x Length 114 mm(4.5")
 : Envelope220*132 Width 220 mm(8.7") x Length 132 mm(5.2")
 : Japanese CHOUKEI 3 Width 120 mm x Length 235 mm *
 : Japanese CHOUKEI 4 Width 90 mm x Length 205 mm *
 : Japanese YOUKEI 1 Width 120 mm x Length 176 mm *
 : Japanese YOUKEI 2 Width 114 mm x Length 162 mm *
 : Japanese YOUKEI 3 Width 98 mm x Length 148 mm *
 : Japanese YOUKEI 4 Width 105 mm x Length 235 mm *
 * except for glue.

Thickness : N/A

Weight : #10,DL,C6 45 g/m 2 (12 lb.) - 75 g/m 2 (20 lb.)
 : CHOUKEI 50 g/m 2 (43Kg) - 70 g/m 2 (60Kg)
 : YOUKEI 50 g/m 2 (43Kg) - 100 g/m 2 (86Kg)

Quality : #10,DL,C6 Bond paper, Plain paper, Air mail
 : CHOUKEI4,3 Kraft, new Kent paper
 : YOUKEI1,2,3,4 Kraft, new Kent paper

* Envelope printing is only available at normal temperature.
 * Keep the longer side of the envelope horizontally at setting.

□ Exclusive paper

Quality : EPSON Exclusive paper

* Transparency printing is only available at normal temperature.

< Photo Quality Ink Jet Paper >

Size : A4 (210mm x 297mm)
 : A6 (105mm x 148mm)
 : B5 (182mm x 257mm)
 : Letter (216mm x 279mm)
 : Legal (216mm x 356mm)
 : 5" x 8" (127mm x 203mm)
 : 8" x 10" (203mm x 254mm)
 : Post Card (100mm x 148mm)

Thickness : 0.13 mm(0.005")

Weight : 98 g/m 2 (26 lb.84Kg)

<360 dpi Ink Jet Paper >

Size : A4 (210mm x 297mm)
 : Letter (216mm x 279mm)

Thickness : 0.11 mm(0.004")

Weight : 89 g/m 2 (24 lb.78Kg)

<RC paper>

Size : A4 (210mm x 297mm)
 : Letter (216mm x 279mm)

Thickness : <T.B.D.>

Weight : <T.B.D.>

<Ink Jet Transparencies>

Size : A4 (210mm x 297mm)
 : Letter (216mm x 279mm)

Thickness : 0.13 mm(0.005")

Weight : N/A

< Photo Quality Glossy Film >

Size : A4 (210mm x 297mm)
 : A6 (105mm x 148mm)
 : Letter (216mm x 279mm)
 Thickness : 0.13 mm(0.005")
 Weight : N/A

<Matte paper Heavy weight>

Size : A4 (210mm x 297mm)
 : Letter (216mm x 279mm)
 Thickness : 0.23 mm(0.009")
 Weight : 167 g/m² (44 lb.143Kg)

< Iron-on Cool Peel Transfer Paper >

Size : A4 (210mm x 297mm)
 : Letter (216mm x 279mm)
 Thickness : 0.18 mm(0.007")
 Weight : 124 g/m² (33 lb.107Kg)

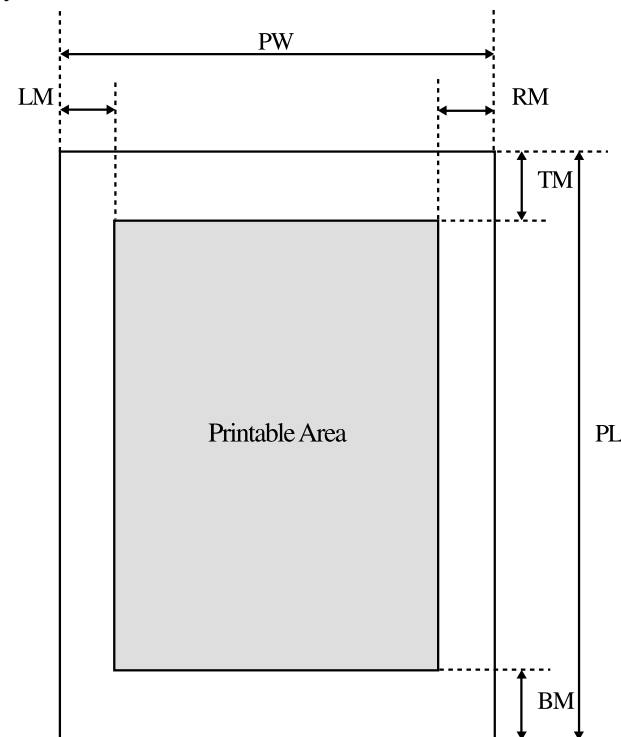
*Base paper weight.

<Ink jet paper>

Size : A4 (210mm x 297mm)
 Thickness : 0.11 mm(0.004")
 Weight : 80 g/m² (21 lb.45Kg)

1.6.3 Printing Area

□ Cut Sheet

**Figure 1-4. Printable Area for Cut Sheet**

Raster Graphics mode

Paper size	PW (Paper width) (typ.)	PL (Paper length) (typ.)	LM (left margin) (min.)	RM (Right margin) (min.)	TM (Top margin) (min.)	Black BM (Bottom margin) (min.)	Color BM (Bottom margin) (min.)
A4	210mm (8.3")	297mm (11.7")	3mm (0.12")	3mm (0.12")	3mm (0.12")	14mm (0.54") /3mm (0.12")	21mm (0.83") /3mm (0.12")
Letter	216mm (8.5")	279mm (11.0")	3mm (0.12")	3mm (0.12")	3mm (0.12")	14mm (0.54") /3mm (0.12")	21mm (0.83") /3mm (0.12")
B5	182mm (7.2")	257mm (10.1")	3mm (0.12")	3mm (0.12")	3mm (0.12")	14mm (0.54") /3mm (0.12")	21mm (0.83") /3mm (0.12")
Lega	216mm (8.5")	356mm (14.0")	3mm (0.12")	3mm (0.12")	3mm (0.12")	14mm (0.54") /3mm (0.12")	21mm (0.83") /3mm (0.12")
Statement	139.7mm (5.5")	215.9mm (8.5")	3mm (0.12")	3mm (0.12")	3mm (0.12")	14mm (0.54") /3mm (0.12")	21mm (0.83") /3mm (0.12")
Executive	190.5mm (7.5")	254mm (10")	3mm (0.12")	3mm (0.12")	3mm (0.12")	14mm (0.54") /3mm (0.12")	21mm (0.83") /3mm (0.12")

* Bottom margin is expanded to 3mm when paper dimension is defined by using command(ESC (S), otherwise it is not expanded (Black,14mm Color 21mm). Refer to Appendix C.

** Print quality may decline in the expanded areas(For 3 mm to 14 mm (Color 21mm) of the printing areas).

Envelope

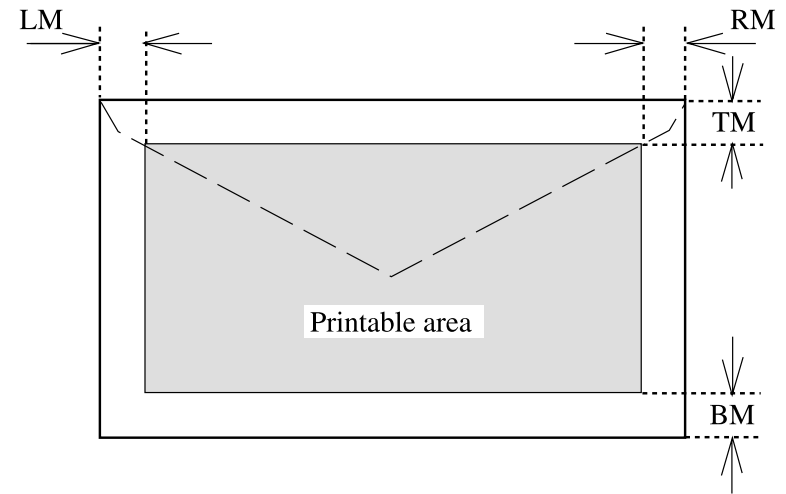


Figure 1-5. Printable Area for Envelopes

Paper size	LM(Left margin) (min.)	RM(Right margin) (min.)	TM(Top margin) (min.)	Black BM (Bottom margin) (min.)	Color BM (Bottom margin) (min.)
#10	28mm(1.10")	3mm(0.12")	3mm(0.12")	14mm(0.54") /3mm(0.12")*	21mm(0.83") /3mm(0.12")*
DL	7mm(0.28")	3mm(0.12")	3mm(0.12")	14mm(0.54") /3mm(0.12")*	21mm(0.83") /3mm(0.12")*
C6	3mm(0.12")	3mm(0.12")	3mm(0.12")	14mm(0.54") /3mm(0.12")*	21mm(0.83") /3mm(0.12")*

* Bottom margin is expanded to 3mm when paper dimension is defined by using command ESC (S), otherwise it is not expanded (Black,14mm Color 21mm). Refer to Appendix C.

** Print quality may decline in the expanded areas(For 3 mm to 14 mm (Color 21mm) of the printing areas).

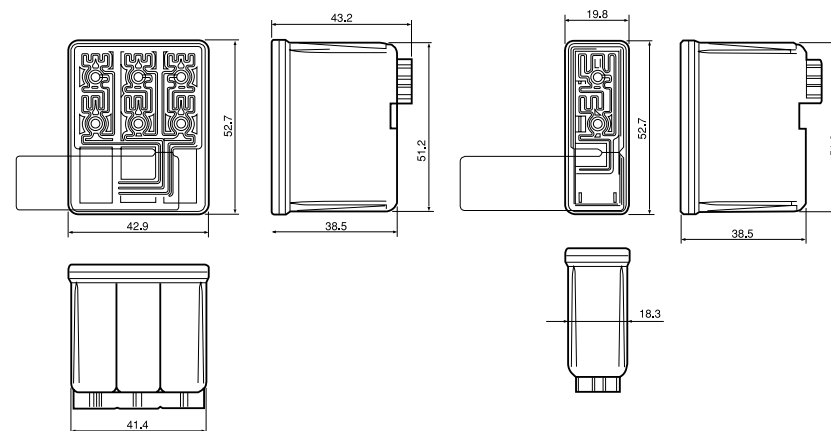
1.7 INK CARTRIDGE

1.7.1 Black Ink Cartridge

Type	: Exclusive cartridge
Color	: Black
Print capacity	: 270 pages / A4 (ISO/IEC10561 Letter Pattern at 360 dpi)
Ink life	: 2 years from production date
Storage temperature	: -20°C - 40°C (Storage, within a month at 40°C) : -30°C - 40°C (Packing storage, within a month at 40°C) : -30°C - 60°C (Transit, within 120 hours at 60°C and within a month at 40)
Dimension	: 19.8 mm(W) x 52.7 mm(D) x 38.5 mm(H)

1.7.2 Color Ink Cartridge

Type	: Exclusive cartridge
Color	: Magenta, Cyan, Yellow
Print capacity	: 150 pages /A4 (360 dpi, 5% duty each color)
Ink life	: 2 years from production date
Storage temperature	: -20°C - 40°C (Storage, within a month at 40°C) : -30°C - 40°C (Packing storage, within a month at 40°C) : -30°C - 60°C (Transit, within 120 hours at 60°C and within a month at 40)
Dimension	: 42.9 mm(W) x 52.7 mm(D) x 38.5 mm(H)



Ink cartridge (color)

Ink cartridge (black)

- * Ink cartridge can not re-fill, only ink cartridge is prepared for article of consumption.
- * Do not use the ink cartridge which was passed away the ink life.
- * Ink will be frozen under -18 to -21 o C environment, however it will be usable after placing it more than 3 hours at room temperature. mm (0.12") *

CHAPTER

2

OPERATING PRINCIPLES

2.1 Overview

This section describes the operating principles of the printer mechanism and electrical circuit boards. The Stylus C40UX/C40SX/C20UX/C20SX has only the following two circuit boards:

- Main board: C413 MAIN/MAIN-B
- Power supply board: C417 PSB/PSE

2.1.1 Printer Mechanism

The printer mechanism for Stylus C40UX/C40SX/C20UX/C20SX is designed newly. But, the basic component of the printer mechanism is same as previous product. This printer consists of Print Head, Carriage Mechanism, Paper Feeding Mechanism, Paper Loading Mechanism, Ink System (Pump Mechanism, Cap Mechanism, and Carriage Lock Mechanism).

Like other EPSON ink jet printers, the Stylus C40UX/C40SX/C20UX/C20SX is equipped with two stepping motors; one for ASF, Paper feeding/ Pump mechanism, and one for CR mechanism. ASF unit uses rear entry front eject system. This ASF unit is also designed newly and single LD roller loads the paper to the printer mechanism.

For cap assembly, Stylus C40UX/C40SX/C20UX/C20SX uses valveless mechanism; new design for this model.

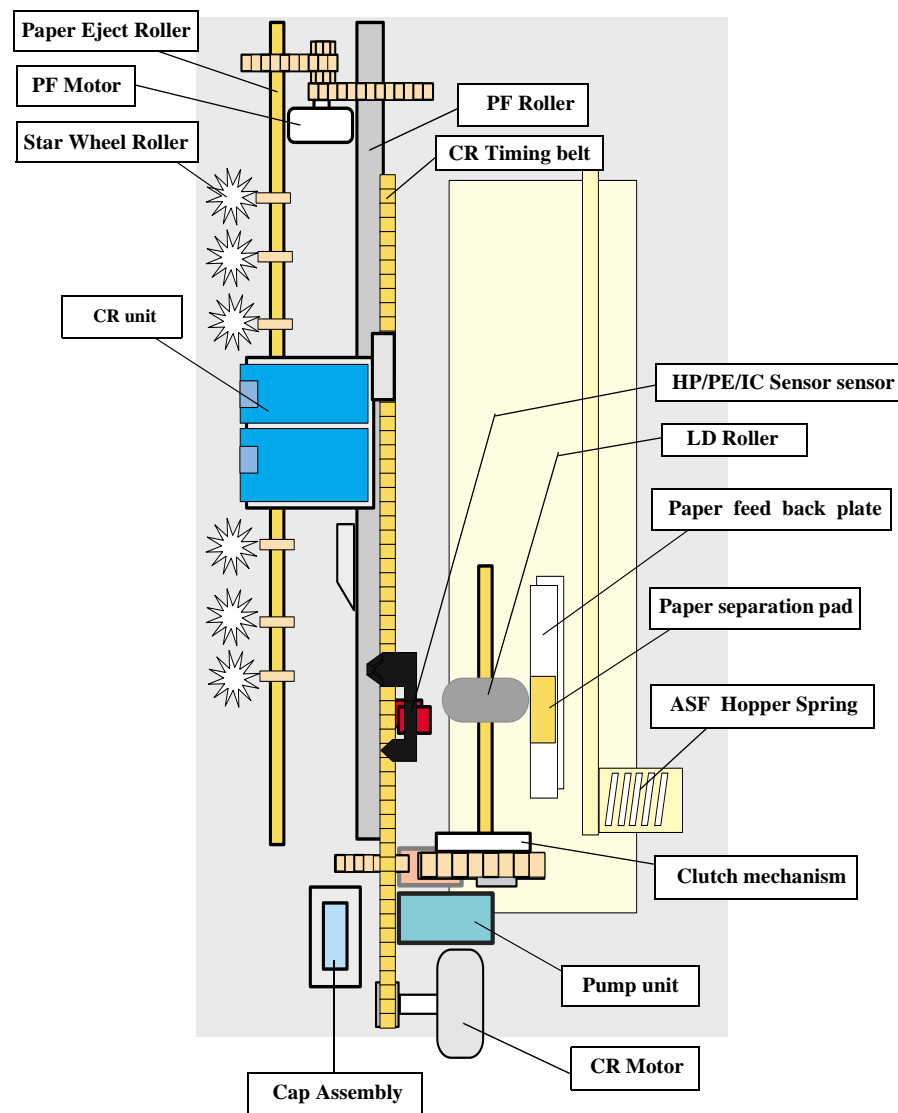


Figure 2-1. Printer Mechanism block diagram

2.1.2 Printhead

The printhead uses a new developed U-CHIPS head and Stylus C40UX/C40SX/C20UX/C20SX can perform multiple shot printing and variable printing. Printhead nozzle configuration is as follows.

- 48 nozzles x 1 row: Black (nozzle pitch of the row: 1/120 inch)
- 45 nozzles x 1 row: Color (nozzle pitch of the row: 1/120 inch)
In the one row for the color, 15 nozzles are assigned for each yellow, magenta, cyan color)

The basic operating principles of the printhead, which plays a major role in printing, are the same as previous models; on-demand method which uses PZT (Piezo Electric Element). In order to uniform the amount of ejecting ink, the printhead has its own head ID (6 digits for this printhead) which adjust PZT voltage drive features. The printer read the head ID form EEPROM and generates appropriate PZT drive voltage to prevent amount of ink from varying by printheads.

Following explains printhead basic components.

- PZT
PZT is an abbreviation of Piezo Electric Element. Certain amount of voltage expands and contracts PTZ. The drive wave generated on MAIN board drives PZT and PZT pushes the top cavity which has ink stored to discharge the ink from each nozzle on the nozzle plate.
- Ink Cavity
The ink absorbed from the ink cartridge goes through the filter and then is stored temporarily in this tank called “cavity” until PZT is driven.
- Nozzle Plate
The board with nozzle holes on the printhead surface is called Nozzle Plate.
- Filter
When the ink cartridge is installed, if any dirt or dust around the cartridge needle is absorbed into the head, there is a great possibility of causing nozzle clog and disturbance of ink flow, and finally causing alignment failure and dot missing. To prevent this problem, a filter is set below the cartridge needle, where ink is filtered.

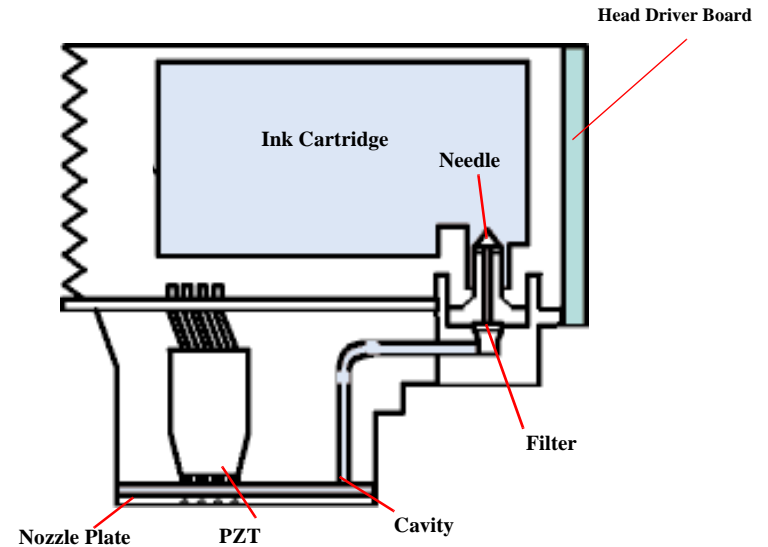


Figure 2-2. Printhead Sectional Drawing

2.1.2.1 Printing Process

This section explains the process in which the printheads of On-Demand inkjet printers eject ink from each nozzle.

1. Normal State:

When no printing signal is sent from PC, or no PZT drive voltage is applied, PZT does not change shape, therefore PZT does not squeeze the cavity. Ink pressure inside the cavity is kept normal. (Refer to Figure 2-3.)

2) Ejecting State:

When the print signal is output from the C413MAIN/B board, IC (Nozzle Selector) located on the printhead unit latches data once by 1-byte unit. An appropriate PZT latched by the nozzle selector is pushed into the cavity by the common voltage applied from the main board. By this operation, ink stored in the cavity spurts out from nozzles. (Refer to Figure 2.1.2.2.)

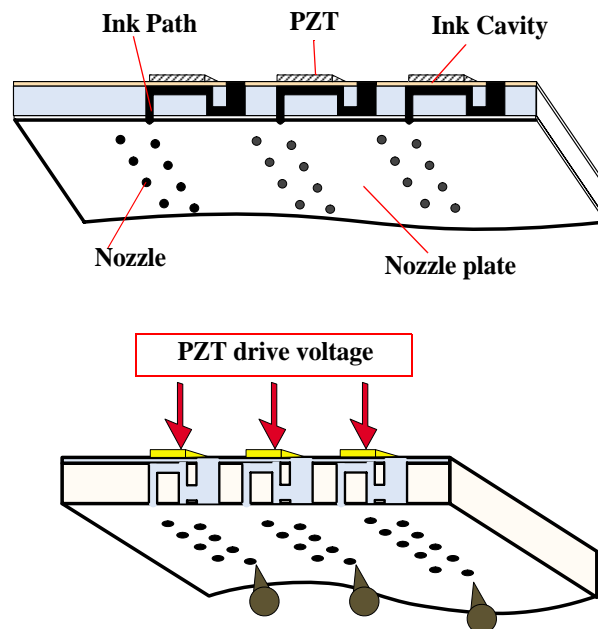


Figure 2-3. Printhead printing process

2.1.2.2 Printing Method

For print dot system, Stylus C40UX/C40SX/C20UX/C20SX has the following two kinds of printing modes.

- Multiple shot printing
- Variable dot printing

The above two printing modes are automatically selected depending on the media and the resolution setting of the printer driver. The following explains each printing mode.

□ Multiple shot printing

This printing mode is developed to improve the print quality on plain paper or transparencies in low resolution. The multiple shot printing mode uses normal dot and the number of dot shots varies from 1 shot to maximum 4 shots depending on the print data to enable sharp image output even in a low resolution.

□ Variable dot printing

This printing mode is developed to improve the print quality on exclusive paper. This mode is basically the same as variable dot printing mode used on other products /; micro dot, middle dot, and large dot compose this mode. Print dot size varies according to print data and this mode enables even sharper image output on exclusive paper.

2.1.3 Carriage Mechanism

The carriage mechanism consists of Carriage motor (CR motor), Carriage unit (including printhead), CR timing belt, CR guide shaft, CR guide frame, CR home & I/C detector (HP/PE/IC sensor) etc. The carriage mechanism moves the carriage back and forth according to the drive from the carriage motor. The following stepping motor is mounted to drive CR mechanism. (See the table below.)

Table 2-1. Carriage Motor Specification

Items	Specifications
Type	4-Phase/ 48-Pole PM Stepping motor
Drive Voltage	+42 V +/- 5% (DRV IC voltage)
Coil Resistance	10.8 Ω +/- 10% (per phase at 25 degree)
Inductance	15 mH +/- 20%(1KH 1VmA)
Drive Method	Bi-Polar drive
Driver IC	XC901503FNR2

The drive from CR motor is transferred to the CR unit via CR timing belt. And the CR home position is detected with the HP/PE/IC sensor. This sensor is available as CR HP detector only in the HP (home position) detection sequence & pump operation sequence. (not available in the paper feeding sequence for the CR HP detector because it is used for only PE sensor during the paper feeding sequence.) Moreover, unlike the previous products, this printer dose not have the PG adjustment mechanism.

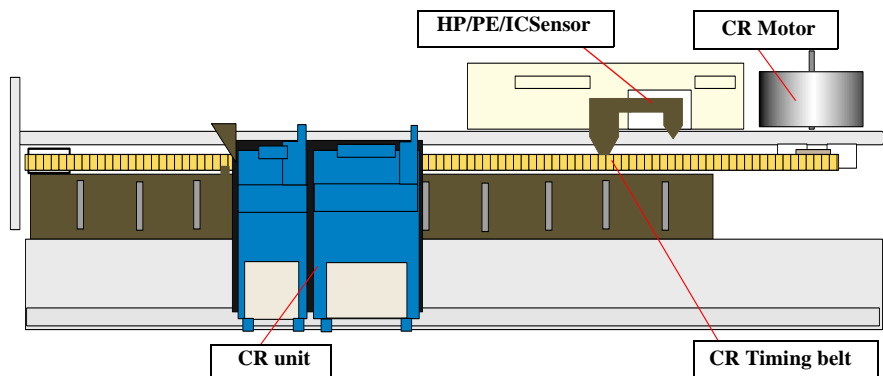


Figure 2-4. Carriage Mechanism (Top view)

CR home position is detected with the HP/PE/IC sensor and the detection plate molded in the CR unit as following figure. When the CR home position is detected with this sensor, HIGH signal is output to the CPU.

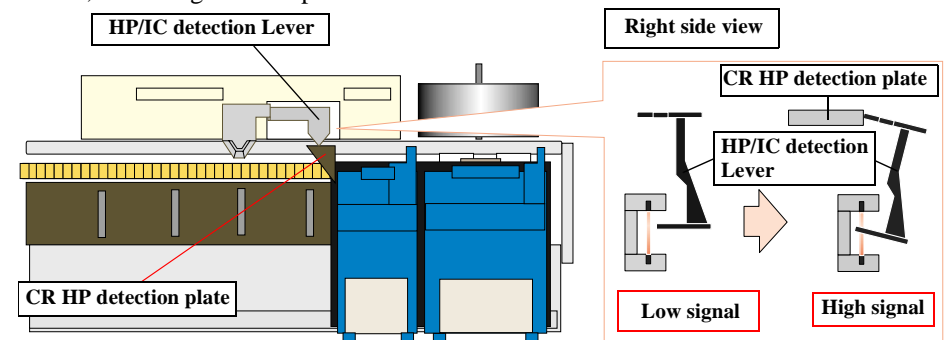


Figure 2-5. CR home position

Unlike the previous products, I/C detection sensor is not built in the CR unit. The I/C is detected with the HP/PE/IC sensor and the detection plate molded on the I/C cover as following figure. The I/C installation condition is monitored only when the CR unit moves to the I/C detection position (HP detection sequence). So, this sensor function is not available in the paper feeding sequence. When the I/C is not installed into the CR unit, HIGH signal is output to the CPU.

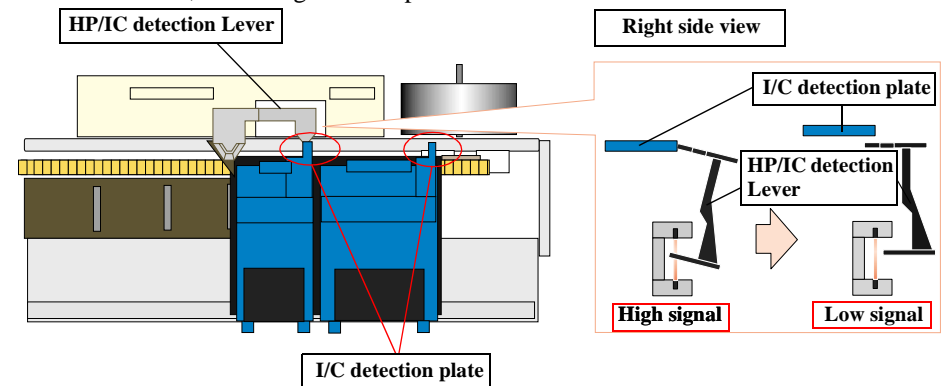


Figure 2-6. I/C detection position

Also, when replacing ink use this lever to confirm whether the cover cartridge is open or closed.

There are separate replacement positions for replacing the Black and Color ink cartridges. If the cover cartridge is open, the I/C detection plate makes contact with the HP/IC detection lever, causing the HP/IC sensor to detect a high signal.

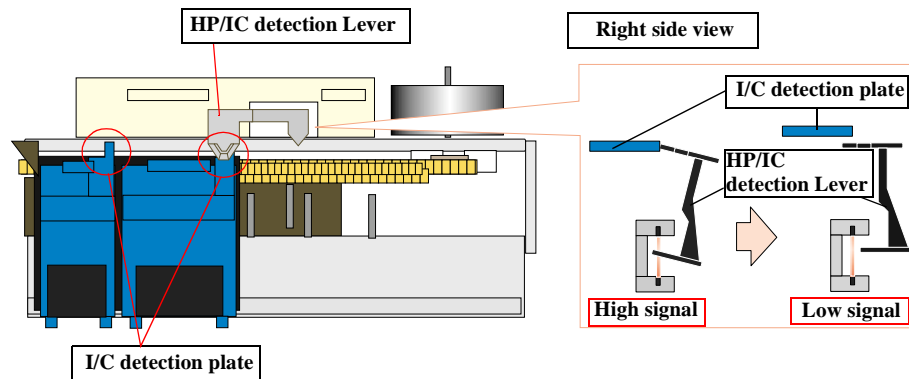


Figure 2-7. I/C change position

If a High signal is detected even once, it is regarded as if that ink cartridge was replaced and the cleaning and ink counters are cleared.

If the High signal is not detected even once, the cleaning and ink counter are not cleared.

If both the ink cartridges have not been set before carrying out initial filling, the carriage moves to the position where both ink cartridges can be set, but checking if the cartridge is open or closed is not done.

If one of the ink cartridges has not been set, the carriage moves to the replacement position of the ink cartridge that is not set due to one time prevention of the set ink cartridge.

2.1.4 Paper Feeding Mechanism

The paper feeding mechanism consists of Paper feed motor (PF motor), PF roller, Paper eject roller, Star wheel roller, and so on. The paper feeding mechanism feeds paper loaded from ASF using the PF roller and Paper Eject Roller & Star wheel roller. For this mechanism, the PF motor mentioned in the right Table 2-2 is used on this product.

The drive of the PF motor is transfer to the PF roller and the Paper Eject Roller as following Figure 2-8. Following shows you how to transfer the PF motor drive to the PF roller and the Paper Eject Roller.

□ PF motor drive transmission path

PF Motor Pinion Gear (CW) → Spur Gear 60 (PF roller)(CCW)
→ Spur Gear 60 (PF roller)(CCW)

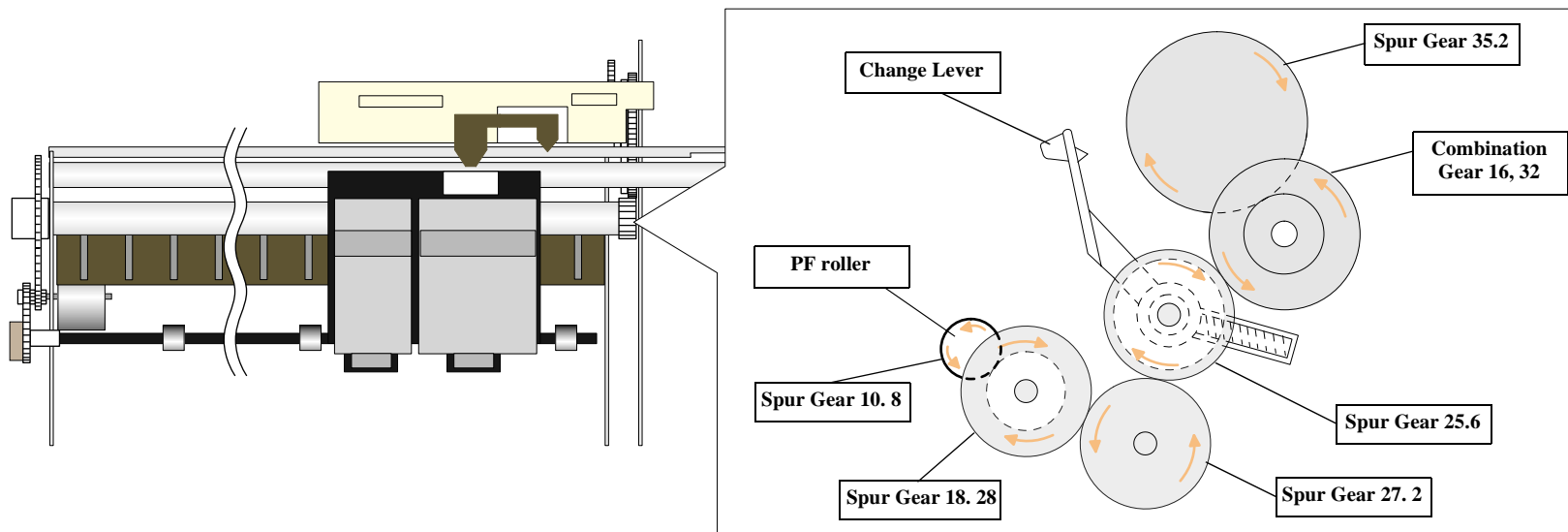


Figure 2-8. Paper Feeding Mechanism

Paper loaded from ASF is advanced by the following roller.

□ Paper feed roller & Paper guide roller (assembled on the Top Frame) → Paper eject roller & Star wheel roller (assembled on the Paper eject frame).

Table 2-2. PF Motor Specifications

Item	Description
Motor type	4-Phase/ 48-Pole PM Stepping motor
Drive voltage	+42 V +/- 5% (DRV IC voltage)
Coil Resistance	10 Ω +/- 10% (per phase)
Inductance	10.5 mH +/- 20% (1kHz 1Vrms)
Driving method	Bi-Polar drive
Driver IC	XC901503FNR2

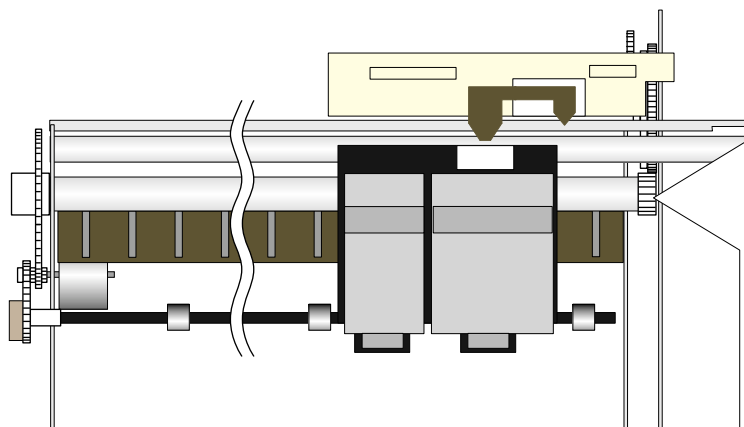
Additionally, the top & end of the paper is detected with the HP/PE/IC sensor. In case the PE sensor does not detect the paper in the paper loading sequence, the printer detects the "Paper out error". If the paper is detected after complete the paper eject sequence, the printer detects the "Paper jam error".

2.1.5 Paper Loading Mechanism (ASF Unit)

The Paper loading mechanism is positioned at the printer rear. The Paper loading mechanism loads paper at the ASF unit and feeds paper to the PF roller.

This ASF unit was designed newly for this product and consists of LD roller, Pad holder (Paper return plate), ASF Frame, Hopper, and so on.

For the major feature of this ASF unit, ASF HP sensor is not used and the single LD roller is built in the ASF unit.



Drive sent from the PF motor is always transmitted to the ASF unit side. But, the Change lever and the Clutch mechanism switch ON/OFF the PF motor drive to the LD roller with the motor rotational direction.

Drive from the PF motor is transmitted to the ASF unit as described below:

□ Switch the PF motor drive to ASF unit side

PF Motor Pinion Gear (CCW) → Spur Gear 60 (PF Roller) (CW) → Spur Gear 10.8 (CW) → Combination Gear 18, 28 (CCW) → Spur Gear 27.2 (CW) → Spur Gear 25.6 (CCW) → Change Lever Rotates (CCW) → Release the Clutch mechanism lock position

Following Figure 2-9 shows you the switching path for PF motor drive to ASF unit side.

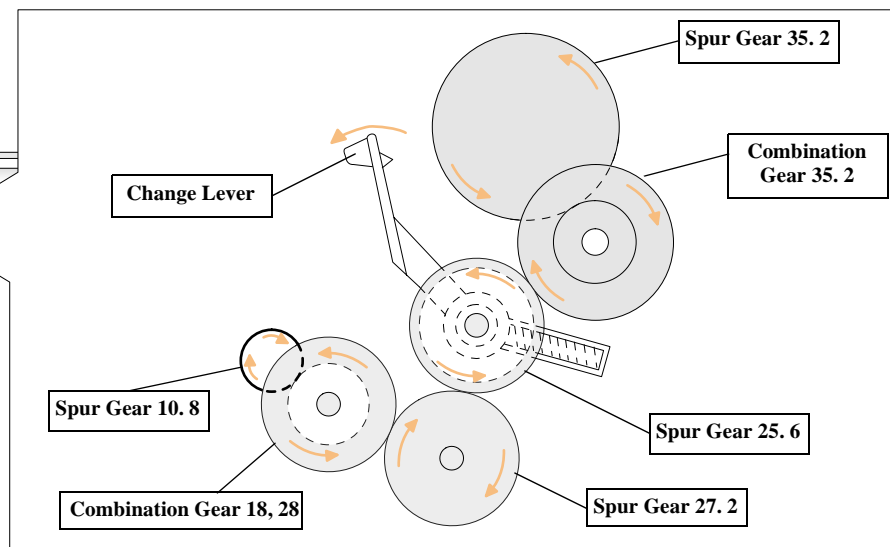


Figure 2-9. Switch the PF motor drive to ASF unit side

❑ **Transfer the PF motor drive to LD roller**

PF Motor Pinion Gear (CW) → Spur Gear 60 (PF Roller) (CCW) → Spur Gear 10.8 (CCW) → Combination Gear 18, 28 (CW) → Spur Gear 27.2 (CCW) → Spur Gear 25.6 (CW) → Change Laver rotates (CW) → Combination Gear 16, 32 (CCW) → Spur Gear 35.2 (CW) (include the clutch mechanism) → LD Roller (CW)

Following Figure 2-9 shows the PF motor drive transmission path to the LD roller unit built in the ASF unit. The LD roller is assembled on the same shaft that the Spur gear 35.2 is assembled.

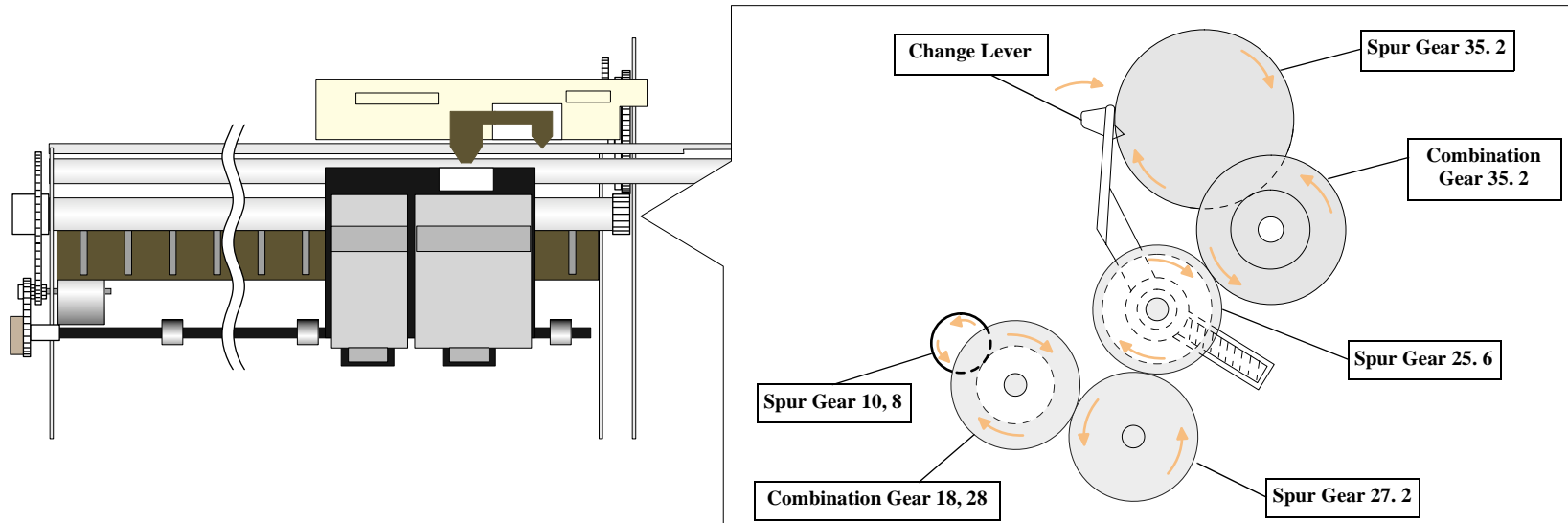


Figure 2-10. PF motor drive transmission path

When the PF motor torque is switched to the ASF unit side by the clutch mechanism, the function of the ASF mechanism varies depending on the rotational direction of the PF motor, as shown in the table below.

Table 2-3. ASF unit function & PF Motor rotational direction

Directions	Corresponding Functions
Clockwise (*1)	<ul style="list-style-type: none"> Picks up and loads paper
Counterclockwise (*1)	<ul style="list-style-type: none"> Release the DE lever & Clutch mechanism

(*1): The PF Motor rotational direction = seen from the right side of the printer.

❑ **Clutch Mechanism**

Unlike the previous products, this product dose not have a ASF HP sensor. Instead of the ASF HP sensor, Change lever and the Clutch mechanism are used to detect the ASF home position. Following figures describe the mechanism.

NOTE:

The Clutch gear is molded on the back side of the Spur gear 35.2 such as Combination gear.

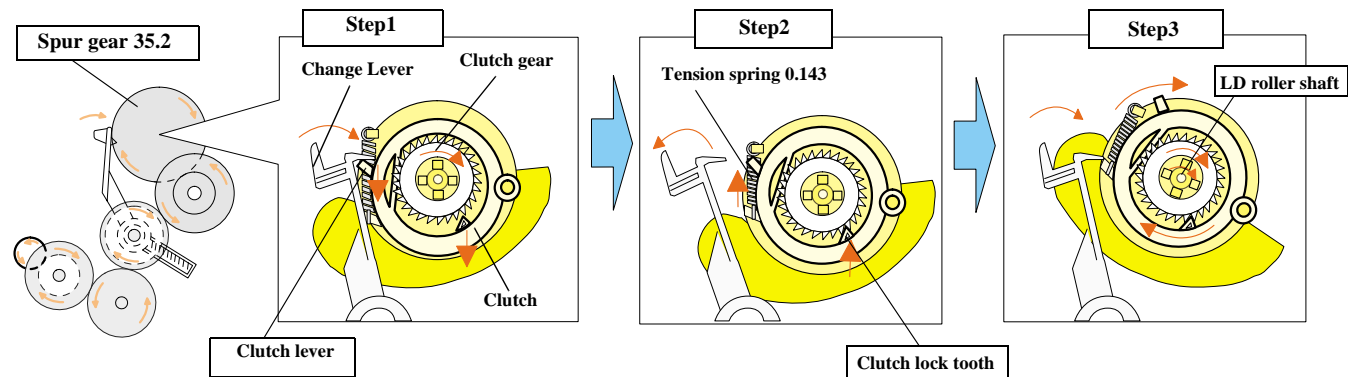


Figure 2-11. Disengage & Clutch mechanism

The Clutch mechanism transmits the PF motor drive to the LD roller shaft only when the Clutch gear rotates CW direction after the Change lever releases the Clutch lever. If the Clutch gear rotates CCW direction, the PF motor drive is not transmitted to the LD roller. This is due to the combination of the shape of the Clutch gear and the Clutch lock tooth such as described on the figure.

1. When the paper is advanced with the PF roller, the Change lever is set on the Clutch lever and the Clutch is pushed down as above Step1's figure. As the result, the Clutch gear (*1) is released from the Clutch lock tooth and the drive from the PF motor is not transmitted to the LD roller shaft.
2. When the PF pinion gear rotates CCW direction in the above Step2's figure, the Change lever moves to the left direction with the CCW rotation of Spur gear 25.6. The Clutch turns back to the engagement position by the tension force of the Tension spring 0.143 and the Clutch gear is engaged with the Clutch lock tooth as above Step2's center figure.
3. When the PF pinion gear rotates CW direction in the above Step3's figure, the Change lever moves to the right direction with the CW rotation of the Spur gear 25.6. And the drive from the PF motor is transmitted to the LD roller shaft via Clutch gear and Clutch lock tooth.
4. The LD roller shaft rotates about 360 degree and the Change lever push the Clutch lever and the PF motor drive is interrupted. This position is the ASF home position.

□ Paper Return Plate (Pad holder)

Unlike the previous products, The Paper return plate is built in the ASF frame instead of the Paper return lever. The Paper separation pad is also stacked on the plate. It works with the spring force of the Torsion spring 26 (mounted in the ASF frame) as following figure.

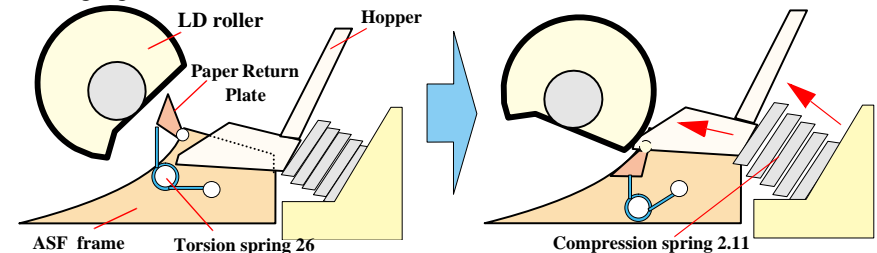


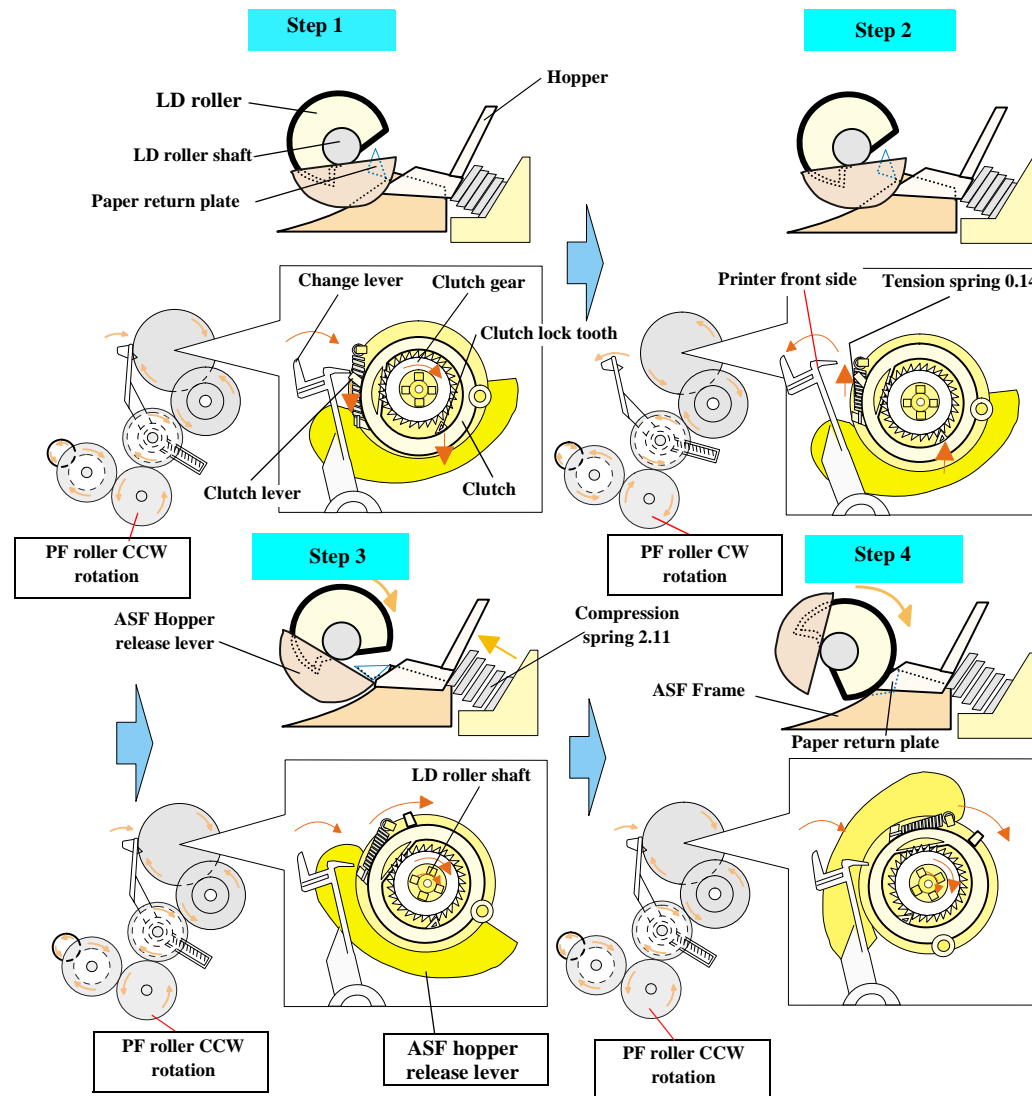
Figure 2-12. Paper Return Plate

The Paper return plate is set to return the paper to the paper stand-by position in the ASF unit when the ASF unit is in the standby mode. When the paper is fed with the LD roller, the Paper return plate is stored in the ASF frame by the LD roller.

Following figures show you the ASF paper loading sequence and the operation of the each mechanism.

When the paper is advanced with the PF roller, Change lever push down the Clutch lever as right figure and the Clutch lock tooth is disengaged from the Clutch gear. As the result, the drive from the PF motor is interrupted and the LD roller dose not rotate. This position is the ASF home position. The Paper return plate is set to avoid that the paper is slipped down from the paper set position.

The PF motor pinion gear rotates CW direction and the drive from the PF motor is transmitted to the ASF LD roller shaft through the Clutch lock tooth and the Clutch gear. The ASF hopper release lever rotates with the ASF LD roller and release the ASF Hopper. The ASF hopper is pushed with the Compression spring 2.11 and the paper is picked up with the ASF LD roller.



When the paper is loaded (pick up) from the ASF unit, the Change lever moves to the printer front side with the CCW rotation of the PF motor pinion gear and releases the Clutch lever. As the result, the Clutch turns back to the engagement position by the tension force of the Tension spring 0.143. And the Clutch lock tooth is engaged with the Clutch gear as right figure.

The ASF LD roller rotates CW direction moreover and the Paper return plate is stored under the ASF frame. The paper is advanced up to the PF roller, and the ASF LD roller & the clutch rotate to the "Step1" position. The Clutch lever is locked with the Change lever. The drive from the PF motor is interrupted and the drive is transmitted to the PF roller side.

Figure 2-13. ASF Paper Loading Sequence

2.1.6 Ink System Mechanism

Ink system mechanism consists of pump unit (include the CR lock lever) and capping mechanism. Ink system mechanism drives the pump unit that presses cap to the printhead and ejects ink from ink cartridge, head cavity and cap to the waste ink pad.

2.1.6.1 Pump Unit & Wiper mechanism

The pump unit is driven by PF motor. PF motor drive is always transmitted to the paper feeding mechanism and pump unit through the following gears. Refer to the Figure 2-15.

PF Motor Pinion Gear (CCW) → Spur Gear 60 (PF Roller)(CW) → Spur Gear 10.8(CW) → Combination Gear 18, 28 (CCW) → Spur Gear 27.2 (CW)(Pump unit)

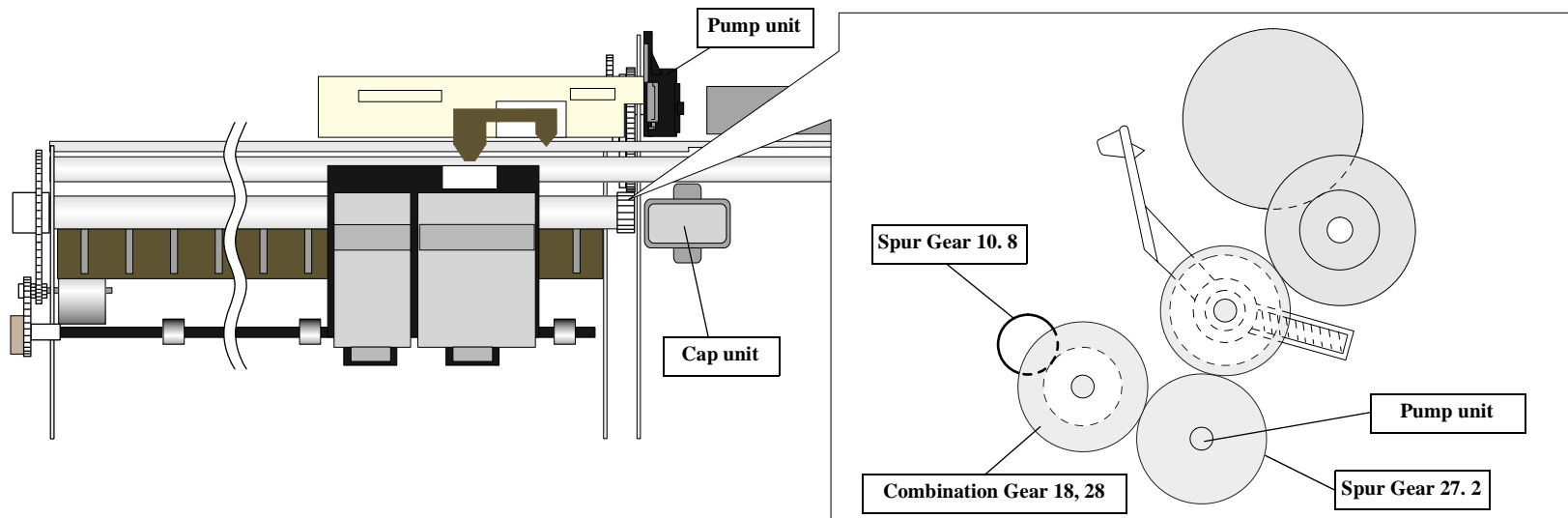


Figure 2-15. PF motor drive transmission path to the Pump unit

Table 2-4. PF motor rotational direction & Ink System Mechanism

Directions	Functions
Counterclockwise (*1)	<ul style="list-style-type: none"> Absorbs ink by the pump unit Set the CR lock lever

(*1): The PF Motor rotational direction = seen from the right side of the printer.

Following figure shows the overview of the pump mechanism operation.

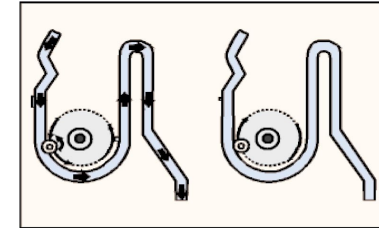


Figure 2-14. Pump mechanism

2.1.6.2 Capping Mechanism

The capping mechanism covers the printheads with the cap holder to prevent the nozzle from increasing viscosity when the printer is in stand-by mode or when the printer is off. This product has valveless cap system. Air valve function used for the previous models pumps and ejects ink only inside the cap by absorbing ink with the valve open. By opening the Air valve, the negative pressure is decreased and only the ink inside the cap is ejected. (the ink is not absorbed from Ink cartridge or head cavity.) But, valveless cap system, this operation is done out side of the capping area. The CR moves to left side of the Cap assembly and the pump absorbs the ink inside the cap.

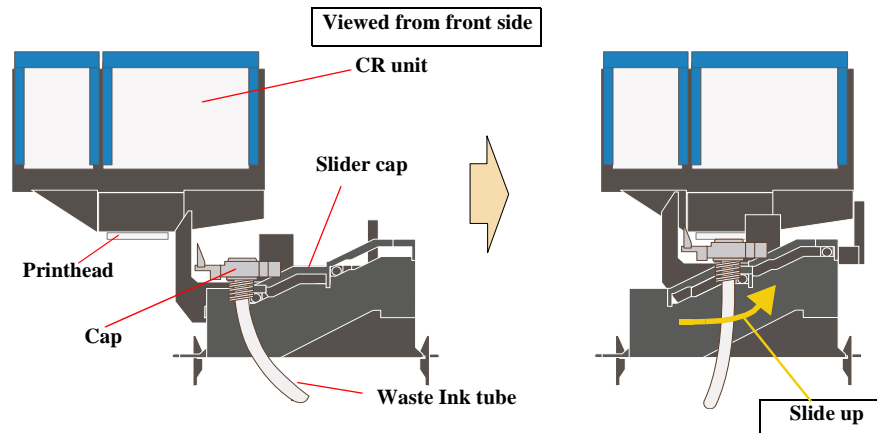


Figure 2-16. Cap Mechanism

Also, unlike previous models, the cap unit is newly designed for this model as follows.

2.1.6.2.1 Wiper with the cap unit

Wiping control is carried out by the procedure shown below.

1. The carriage is moved to the wiper set position. (Refer to Figure 2-17. Wiper Set Position)
2. When the carriage moves to the wiper set position, the hook on the lever lock slider engages, locking the lever lock slider. (Refer to Figure 2-17. Wiper Set Position)

3. If the carriage moves to the left side, spring forces tends to force the cap back to its original position, but it stops at the wiping position due to the lever lock slider. (Refer to Figure 2-17. Wiping Position)
4. When the carriage moves to the left side, the head surface and wiper makes contact and wiping is performed. (Refer to Figure 2-17. Wiping Position)
5. Even when wiping is completed, the carriage moves further to the left side and when the hook on the carriage's right side hits the lever lock slider lever, the lever lock slider's hook is released. (Refer to Figure 2-17. Wiper Set Release)

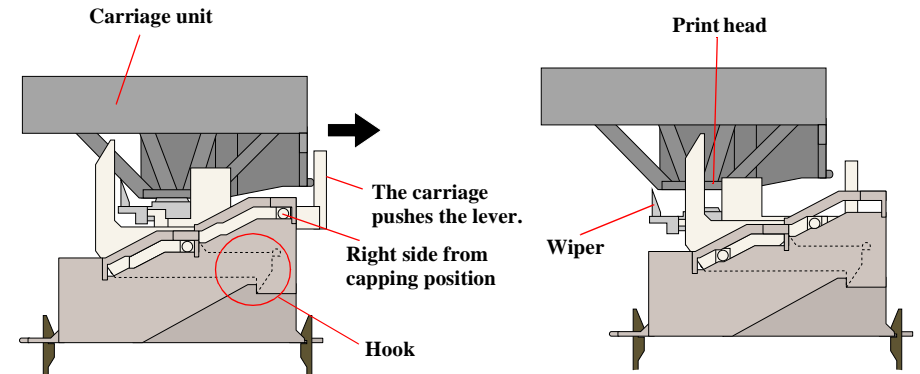


Figure 2-17. Wiper Set Position

Figure 2-17. Wiping Position

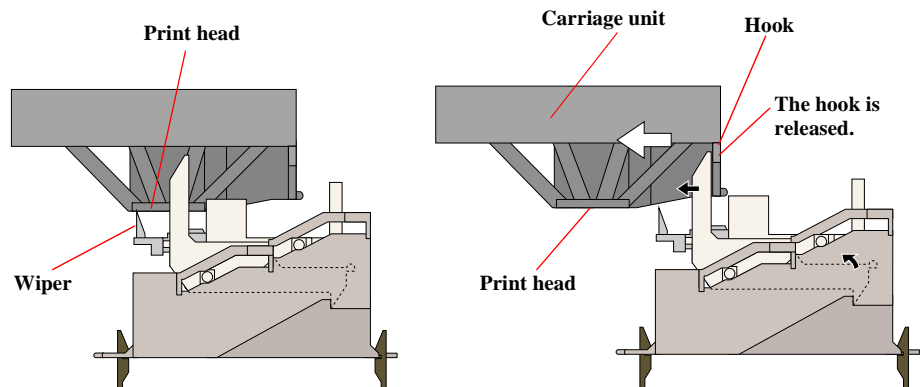


Figure 2-17. Wiping

Figure 2-17. Wiper Release

2.1.6.2.2 Non porous pad in cap

Due to this, the cap is newly designed as follows.

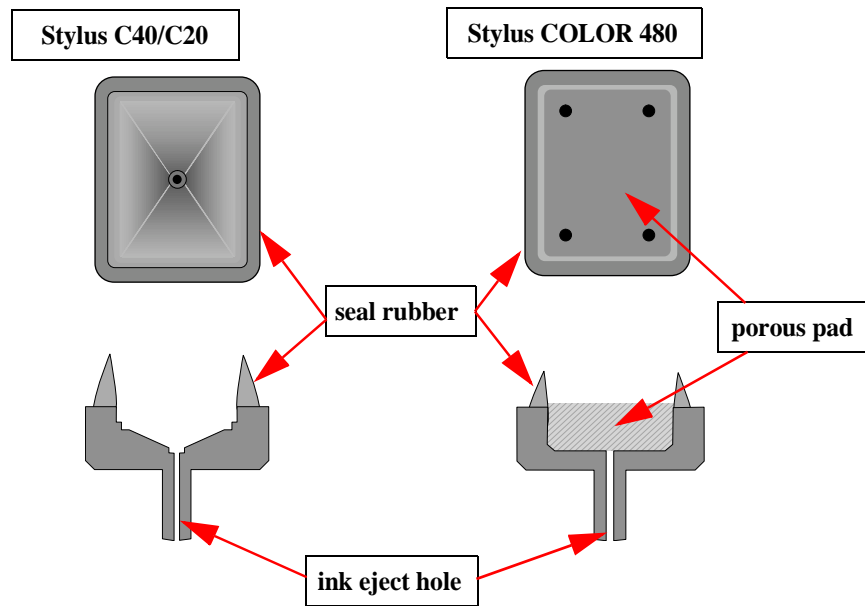


Figure 2-18. non porous pad in cap (Stylus C40/C20)

The cap unit used for the previous models has the porous pad to keep the moisture in the cap and prevent that the air bubble occurs in CL sequence.

To get the same effects on new cap unit without the porous pad.

- For keep the moisture in the cap
The diameter of the ink eject hole is smaller than that of Stylus COLOR 480
- For prevent that the air bubble occurs in CL sequence
The cap is modified so that ink flows to ink eject hole with air bubble in CL sequence.

2.1.7 Ink Sequence

□ Initial ink charge

After the product is purchased and the printer is turned on for the first time, the printer must be performed the initial ink charge and charges ink inside the head cavity. When the initial ink charge is completed properly, the printer releases the flag inside the EEPROM and no initial ink charge will be performed next time the power is turned on. Stylus C40UX/C40SX/C20UX/C20SX takes 70 seconds to complete the initial ink charge sequence and consume about half of the brand-new black ink cartridge. If the power is turned off during initial filling, CL1 is performed when the power is turned on the next time.

□ Manual Cleaning

Stylus C40UX/C40SX/C20UX/C20SX provides three type of manual cleaning to clean air bubbled or clogged ink with viscosity or foreign substances. The following manual CL sequences can be executed by the utility included in the printer driver.

■ CL1

- Ink absorption
Black Ink: 0.175g, Color Ink: 0.175g
- Wiping operation
Wipes nozzle plate by the rubber part on the right half of the wiper.
- Flashing operation
Prevents color from mixing. Stabilizes ink surface inside the nozzle.

■ CL1'

- Ink absorption
Black Ink: 1.02g, Color Ink: 1.02g
- Wiping operation
Wipes nozzle plate by the rubber part on the right half of the wiper.
- Flashing operation
Prevents color from mixing. Stabilizes ink surface inside the nozzle.

■ CL2

- Ink absorption
Black Ink: 0.3g, Color Ink: 0.3g
- Wiping operation
Wipes nozzle plate by the rubber part on the right half of the wiper.
- Flashing operation
Prevents color from mixing. Stabilizes ink surface inside the nozzle.

The above mentioned manual CL is executed by performing nozzle check pattern and manual CL alternately. The cleaning order is CL1→CL2→CL1→CL1'→CL1. Like the previous products, CL1 is selected automatically and performed in case any print check is not executed between each manual CL. Additionally, if the manual CL is performed with over 5 pages printing cycle, CL1 is always selected and performed.

Additionally, if either black or color I/C is ink low or end condition, any manual cleaning is prohibited and it is displayed on the LED indicators.

□ Timer Cleaning

Unlike the previous product, this printer dose not have Timer IC and Lithium battery which is used for the backup power source for Timer IC. So, this printer manages the printer off period or cleaning cycle by using the following method.

The timer command is sent to the printer by the printer driver before printing. The timer command s generated based on the PC's timer and is configured from the year, month, day, hour, minute and second. When the printer receives the timer command, it generates data which include the month, day and time and stores it at addresses 04 <H> and 05 <H> in the EEPROM.

The printer compares the values stored in addresses 02 <H> and 03 <H> with the values stored in addresses 04 <H> and 05 <H> of the EEPROM, and if the compared value is greater than the specified time, timer cleaning is performed automatically. The printer writes the values in EEPROM addresses 02 <H> and 03 <H> in addresses 04 <H> and 05 <H> when cleaning (timer cleaning, manual cleaning, ink cartridge replacement cleaning, etc.) is performed.

A maximum of 0.48 g of ink is consumed (0.24 g each for the single color and color ink cartridges) during timer cleaning.

□ Flashing

This printer performs the following two kinds of the Flashing for the following purpose.

- Periodical Flashing
This is due to avoid the increment of both ink's viscosity in the printhead nozzle during the continuous printing and the specific small amount of the ink is ejected in the cap based on the periodical flashing timer.
- Periodical large amount Flashing
This is due to avoid the increment of black ink's viscosity in the printhead nozzle during the continuous printing and large amount of the ink is ejected in the cap based on the periodical large amount flashing timer.

2.1.8 Printing mode

The print resolution and printing method are determined automatically by setting the media type and print quality (It is able to set by slider bar) in the printer driver as following table. Following table show you the detail setting in the “Auto” mode.

Table 2-5. Printing mode for Color mode

Print media	Slide bar	Resolution	Print mode	High Speed*1	Micro weave	Dot size*2
Plain paper	Speed	120 x 120	Economy	ON	OFF	ND-3dot
	Default	360 x 360	Normal 360	ON	ON	MSD2
	Quality	720 x 720	Photo 720	ON	ON	VSD 6pl
360 dpi Ink jet paper	N/A	360 x 360	Normal 360	OFF	ON	MSD2
Photo Quality ink jet paper	Default	360 x 360	Fine 360	ON	ON	MSD2
	Quality	720 x 720	Photo 720	ON	ON	VSD 6pl
Matte Paper-Heavyweight	Default	360 x 360	Fine 360	ON	ON	MSD2
	Quality	720 x 720	Photo 720	ON	ON	VSD 6pl
Photo paper	Default	360 x 360	Fine 360	ON	ON	MSD2
	Quality	720 x 720	Photo 720	ON	ON	VSD 6pl
Photo Quality Glossy Film	N/A	720 x 720	Photo 720	OFF	ON	VSD 6pl
Ink Jet transparencies	N/A	360 x 360	Normal 360	OFF	ON	MSD2

NOTE: *1: High speed means Bi-directional printing.

*2: ND means Normal dot. MS means Multi Shot Dot.
VSD means Variable Shot dot.

Table 2-6. Printing mode for Black mode

Print media	Slide bar	Resolution	Print mode	High Speed*1	Micro weave	Dot size*2
Plain paper	Speed	120 x 120	Economy	ON	OFF	ND-3dot
	Default	240 x 240	Normal 240	ON	ON	MSD1
	Quality	360 x 360	Fine 360	ON	ON	MSD2
360 dpi Ink jet paper	N/A	360 x 360	Normal 360	OFF	ON	MSD2
Photo Quality ink jet paper	Default	360 x 360	Fine 360	ON	ON	MSD2
	Quality	720 x 720	Photo 720	ON	ON	VSD 6pl
Matte Paper-Heavyweight	Default	360 x 360	Fine 360	ON	ON	MSD2
	Quality	720 x 720	Photo 720	ON	ON	VSD 6pl
Photo paper	Default	360 x 360	Fine 360	ON	ON	MSD2
	Quality	720 x 720	Photo 720	ON	ON	VSD 6pl
Photo Quality Glossy Film	N/A	720 x 720	Photo 720	OFF	ON	VSD 6pl
Ink Jet transparencies	N/A	360 x 360	Normal 360	OFF	ON	MSD2

NOTE: *1: High speed means Bi-directional printing.

*2: ND means Normal dot. MS means Multi Shot Dot.
VSD means Variable Shot dot.

2.2 Electrical Circuit Operating Principles

The electric circuit of the Stylus C40UX/C40SX/C20UX/C20SX consists of the following boards.

- Main board: C413 MAIN (USB)
C413 MAIN-B (Parallel)
- Power supply board: C417 PSB/PSE Board

NOTE: The C413MAIN/-B board is used for the product in the first mass production and it will be changed to C413MAIN-C/-D board at an early date. The major difference is that a single chip which integrates the ASIC, CPU and PROM is used on the C413MAIN-C/-D board.
C413 MAIN-C (USB)
C413 MAIN-B (Parallel)

This section provides operating principles of C413 MAIN/B Board and C417 PSB/PSE Board. Refer to Figure 2-19 for the major connection of the each boards and their roles.

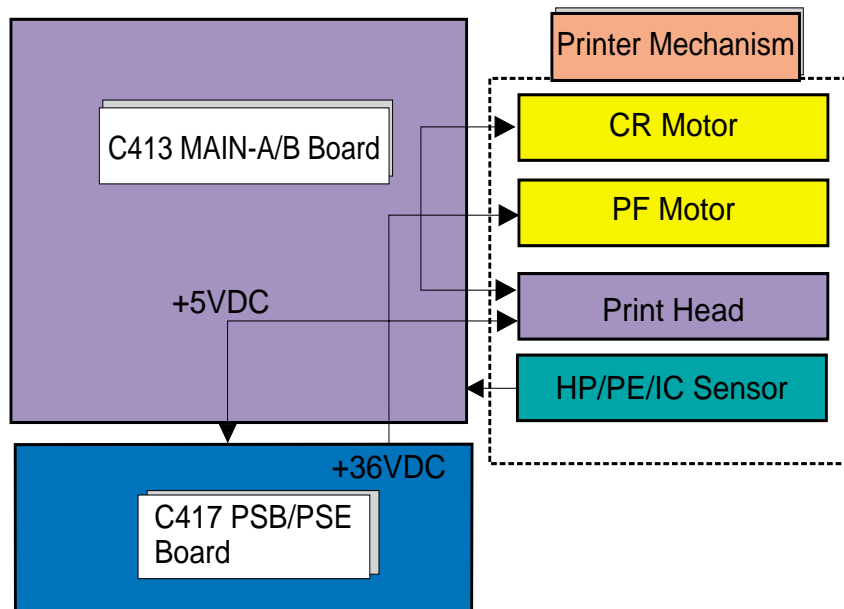


Figure 2-19. Electric Circuit

2.2.1 C417 PSB/PSE board

The power supply boards of Stylus C40UX/C40SX/C20UX/C20SX use a RCC (Ringing Chalk Converter) circuit, which generates +36VDC for drive line and +5VDC for logic line to drive the printer. The application of the output voltage is described below.

Table 2-7. Application of the DC Voltages

Voltage	Application
+36VDC	<ul style="list-style-type: none"> • Motors (CR Motor, PF Motor) • Printhead common voltage • Printhead nozzle selector 36V drive voltage

AC voltage input from AC inlet first goes through filter circuit that removes high frequency components and is then converted to DC voltage via the rectifier circuit and the smoothing circuit. DC voltage is then lead to the switching circuit and FET Q1 preforms the switching operation. By the switching operation of the primary circuit, +36VDC is generated and stabilized at the secondary circuit.

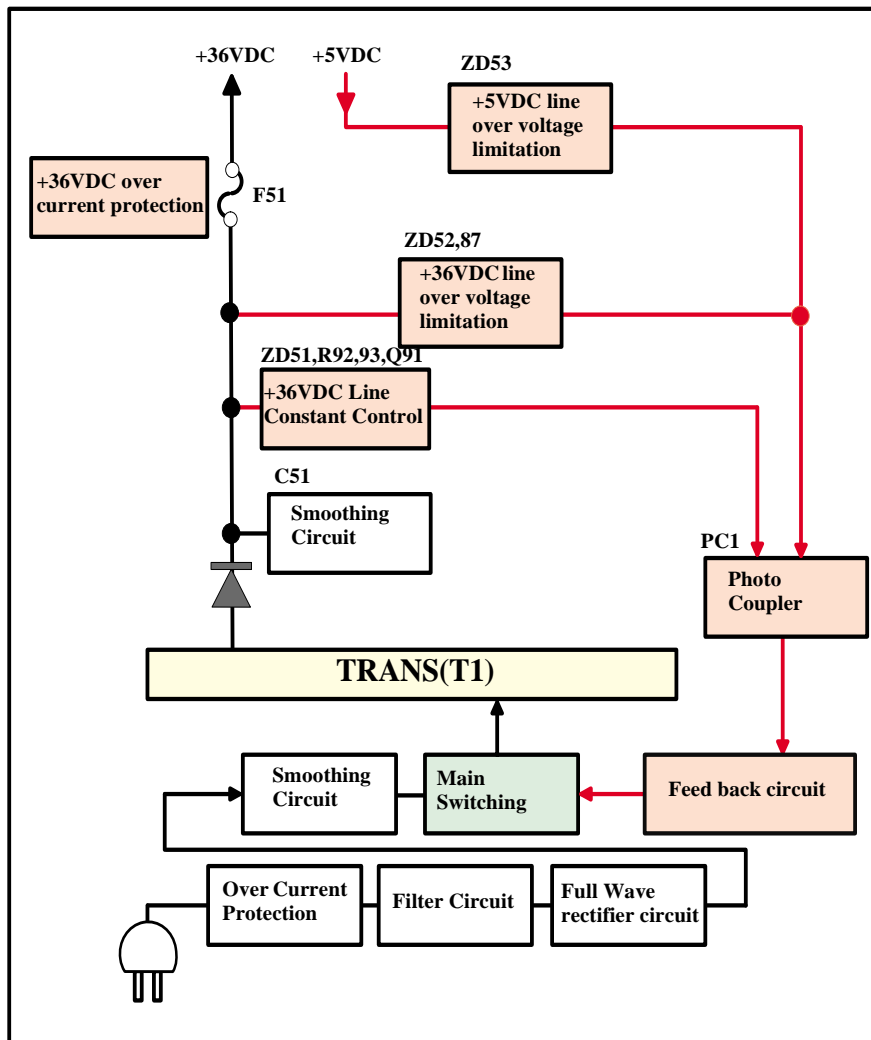


Figure 2-20. C417 PSB/PSE Board Block Diagram

The C417 PSB/PSE board has the various control circuits to stop voltage output if a malfunction occurs on the power supply board or the main board while the printer mechanism is on duty. Following explains each control and protection circuit.

- +36V line constant voltage control circuit:
The output level of +36V line is monitored by a R92, R93, Q91, ZD51.
When +36V line reaches about 36.4V, ZD51 has a continuity with and PC1 start the operation via Q91. Consequently, Q1 switching operation is controlled by this circuit to stabilize the 36V line.
- +36V line over voltage protection circuit:
The output voltage line is monitored by ZD52, ZD87. If the output level of the voltage level of +36VDC line exceeds +48V, this circuit stops the operation of the switching FET Q1 via PC1, Q82, Q83 and prevents high voltage from applied to the secondary side
- +36V line over current protection circuit:
The output voltage is monitored by the F51. When the abnormal current is detected by F51, F51 is fused and cut off the +36V line output to the Main board
- +5V line over voltage protection circuit:
The output voltage level of the +5V line is monitored by ZD53.
If the output level of the voltage level of +5VDC line exceeds +7V, this circuit stops the operation of the switching FET Q1 via PC1, Q82, Q83 and prevents high voltage from applied to the secondary side.

2.2.2 C413 MAIN/B Board

The printer mechanism is controlled by C413MAIN. On this MAIN board, 3.3V regulator IC is not mounted and all IC is driven with 5.0 V. See Figure for the C413 MAIN/B board block diagram.

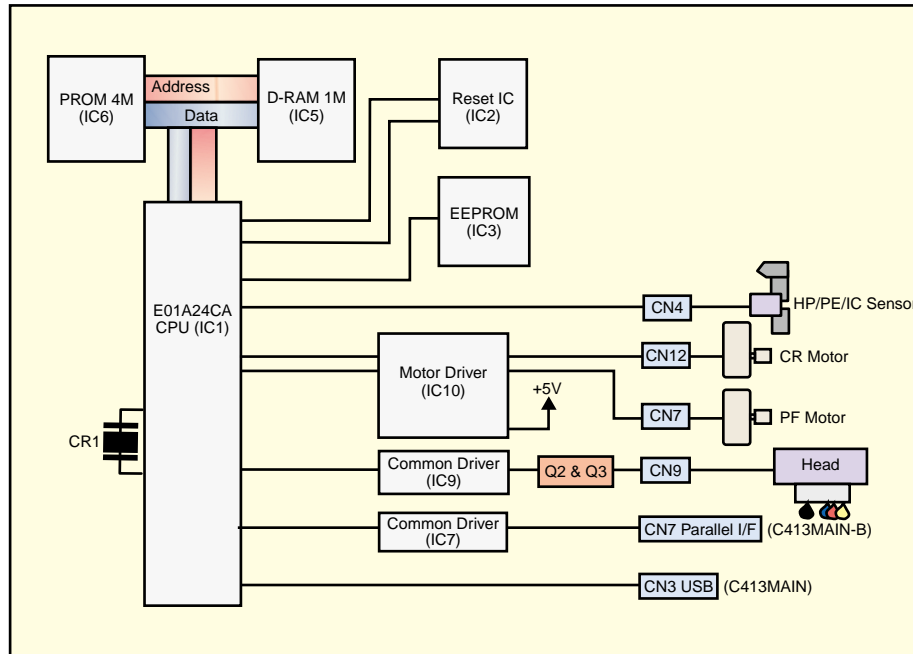


Figure 2-21. Block Diagram for the (C413 MAIN/B) Board

Following shows you the major characteristic of this main board.

- Timer IC & Lithium battery are not mounted
Unlike the previous products, the Timer IC and the Lithium battery are not mounted on the Main board. So, this product perform the Power-on cleaning or Timer cleaning based on the time command which is sent from the printer driver. As for the detail, refer to the 2.1.7 Ink Sequence.
- D-RAM
1Mbit D-RAM is mounted on the Main board.
- One CPU controls the all function on the main board.

2.2.2.1 Main elements

Table 2-8 shows the function of the each main elements on C413MAIN.

Table 2-8. Main Elements

IC	Location	Function
ASIC E01A24NA	IC1	16bit CPU mounted on the MAIN board is driven by clock frequency 24MHz and controls the printer.
PROM	IC6	<ul style="list-style-type: none"> • Capacity 4MB, Bus= 16 bit • Program for CPU
RAM	IC5	Bus= 16 bit, 1Mbit DRAM
AT93C46	IC3	1kbit EEPROM <ul style="list-style-type: none"> • Default value setting • Parameter backup
BH6150F-E2	IC2	Reset IC <ul style="list-style-type: none"> • For +5V; reset when +4.2V is detected • For +36V, reset when +29.2 is detected
E09A39RA	IC9	Head drive control HIC <ul style="list-style-type: none"> • Generates head common voltage.
XC901503FNR2	IC10	<ul style="list-style-type: none"> • CR motor driver • PF motor driver • +5V regulator
74LVX161284	IC7	IEEE1284 parallel I/F transceiver IC.

CHAPTER

3

TROUBLESHOOTING

3.1 Overview

This chapter describes how to identify troubles in two levels: unit level repair and component level repair. Refer to the flowchart in this chapter to identify the defective unit and perform component level repair if necessary. This chapter also explains motor coil resistance, sensor specification and error indication.

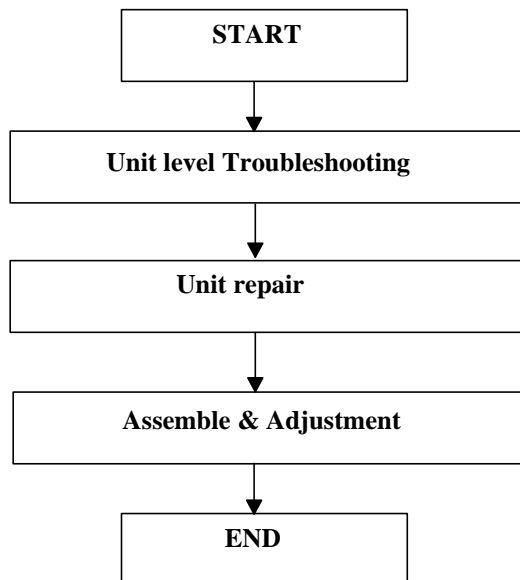


Figure 3-1. Troubleshooting Flowchart

Table 3-1. Motor, Coil Resistance

Motor	Location	Check Point	Resistance
CR Motor	CN12	Pin 1 and 3 Pin 2 and 4	9.6 Ohms \pm 10% (at 25 °C/ phase)
PF Motor	CN7	Pin 1 and 3 Pin 2 and 4	7.35 Ohms \pm 10% (at 25 °C/ phase)

Table 3-2. Sensor Check Point

Sensor Name	Check Point	Signal Level	Switch Mode
HP/PE Sensor	CN4/Pin 1 and 2	Less than 0.7V	Off <ul style="list-style-type: none"> • Out of HP range • No paper • Detect the I/C
		More than 2.4V	On <ul style="list-style-type: none"> • Within HP range • Detect the paper • Not detects the I/C
Thermistor (THM)	TH1 (on the Head driver board)	Analog signal	10 K (at 24 °C)

3.2 Troubleshooting with LED Error Indications

This section describes how to troubleshoot the problem when the printer indicates an error at power on and can not print. The Stylus C40UX/C40SX/C20UX/C20SX can detect the following six errors and seven status, and indicates them with the LEDs, as shows below.

Table 3-3. Error Indicator of Operation Panel

Printer Status	Indicators		Priority
	Power	Error	
Power ON condition	On	-	10
Ink sequence	Blink	-	6
Ink Cartridge change mode	Blink	-	5
Data processing	Blink	-	9
Paper Out	-	On	4
Paper jam condition	-	On	3
Ink end (Black)	-	On → ON	8
Ink level low (Black)	-	Blink → Blink	8
Ink end (Color)	-	On → ON	8
Ink level low (Color)	-	Blink → Blink	8
Ink end (Black and Color)	-	ON → ON	8
No Ink Cartridge (Black and Color)	-	On	7
Maintenance request (Ink Overflow Counter error)	Alt Blink	Alt Blink	2
Fatal error	Off	On	1

" - " : Indicator status don't change.

" A -> B " : A is a indicator condition when carriage is on Home Position.

B is a indicator condition in Ink exchange sequence.

See the following tables which show the error conditions and corresponding possible causes:

Table 3-4. Error Condition and possible cause

Symptom	Possible Cause	Check table
Paper out error indication (Paper is not loaded correctly)	<ul style="list-style-type: none"> The friction of the LD roller is lowered due to the paper dust. The clutch mechanism is broken. Tension spring 0.143 come off in the clutch mechanism. Compression spring 1.47 comes off. Tip of Change lever has any damage. PF motor is broken. 	Table 3-5 Table 3-6 Table 3-7
Paper jam error indication	<ul style="list-style-type: none"> Star wheel assembly is not assembled on the Paper eject frame. The Spur gear 10.8 is not assembled correctly. The paper guide front is not assembled correctly or has any damage. The PE detection lever dose not move smoothly. 	Table 3-8 Table 3-9 Table 3-10
Multiple papers are always loaded	<ul style="list-style-type: none"> The paper return plate dose not work correctly. 	Table 3-13
Paper is always loaded without any print job	<ul style="list-style-type: none"> The Change lever is broken in the Clutch mechanism. 	Table 3-14
Fatal error indication	<ul style="list-style-type: none"> HP sensor lever or PE sensor lever dose not move smoothly. HP/PE sensor is defective. CR motor is defective. PF motor is defective. Main board is defective. Printer Housing dose not secured with screw on -the printer mechanism. 	Table 3-14 Table 3-15 Table 3-15

Table 3-4. Error Condition and possible cause (continued)

Symptom	Possible Cause	Check table
Any error indication is not displayed. But, the paper is not ejected completely. Paper jam dose not occur.	<ul style="list-style-type: none"> Paper eject roller gear is disengaged from the pump's gears. The Paper eject frame is not assembled in the Paper eject frame. 	Figure 3-16
Dot missing occur and it is not recovered with CL	<ul style="list-style-type: none"> Pump unit dose not absorb the ink from the printhead. Cap unit dose not stick on the surface of the printhead completely. The printhead is broken. The head FFC has any damage. The main board is defective. 	Figure 3-17 Figure 3-18 Figure 3-19
Print quality is not good <ul style="list-style-type: none"> Vertical banding Horizontal banding Printing is blurred Ink stains the paper 	<ul style="list-style-type: none"> The accuracy of the CR motor is lowered. The lack of the lubricant around the CR unit. The both I/C is not held in the CR unit securely. The Paper eject frame is deformed. Any foreign material is sticking around the printhead. Paper feed accuracy is lowered. Printer driver setting is not suitable. Paper path has ink stain somewhere. 	Table 3-20 Table 3-21 Table 3-22

If the problem fits to the detail phenomenon in the table, make sure the check point and repair the product following the corresponding remedy mentioned in the table when you find the defective parts in the check point.

Table 3-5. Paper out error indication

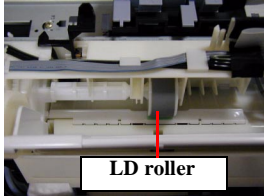
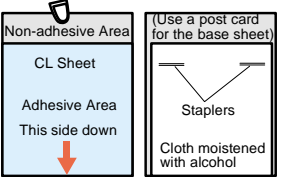
Step No.	Detail phenomenon	Check point	Remedy
1	ASF LD roller attempt to load the paper. But, paper is not loaded at all. The LD roller seems slipping.	<ul style="list-style-type: none"> Check the surface of the LD roller if the micro pearl or severe smear is adhered.  <p>If it is no problem, proceed the next step.</p>	<ul style="list-style-type: none"> Set a cleaning sheet in the ASF up side down. Then holding the top edge, try to load the paper from the Printer driver. The micro pearl on the LD roller surface is removed. To remove severe smear, staple a cloth moistened with alcohol to a post card and clean the roller in the same manner.  <ul style="list-style-type: none"> If the problem is not solved, replace the LD unit with new one.

Table 3-6. Paper out error indication

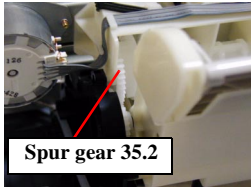
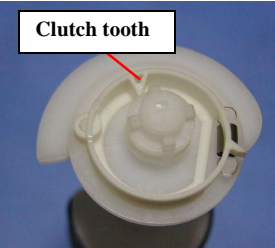
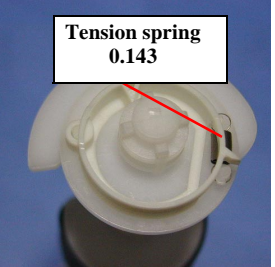
Step No.	Detail phenomenon	Check point	Remedy
2	ASF LD roller dose not attempt to load the paper. But, the PF motor and the Spur gear 35.2 is rotating. 	<ul style="list-style-type: none"> Check if the clutch tooth is broken.  If it is no problem, proceed the next step.	<ul style="list-style-type: none"> Replace the LD unit with new one.
3	ASF LD roller dose not attempt to load the paper. But, the PF motor and the Spur gear 35.2 is rotating.	<ol style="list-style-type: none"> Check if the tension spring 0.143 comes off in the Clutch mechanism. 	<ol style="list-style-type: none"> Set the tension spring 0.143 in the clutch mechanism. Set the Compression spring 1.47 in the Change lever.

Table 3-7. Paper out error indication

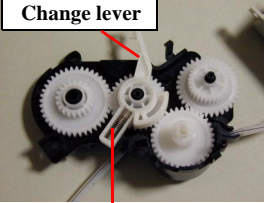
Step No.	Detail phenomenon	Check point	Remedy
4	When the print data is sent to the printer, ASF LD roller continue to load the paper even if the first paper is loaded to the PF roller and the paper is ejected while the ASF hopper is flapping.	<ol style="list-style-type: none"> Check if the tip of the Change lever has any damage.  <ol style="list-style-type: none"> Check if the Compression spring 1.47 comes off from the Change lever. If it is no problem, proceed the next step.	<ol style="list-style-type: none"> Replace the Change lever (Printer mechanism) with new one. Set the Compression spring 1.47 in the Change lever.
5	When the printer is turned on, PF motor dose not operate at all in the power on sequence.	<ol style="list-style-type: none"> Check if the PF motor connector is connected to the CN7. Check if the PF motor coil resistance is about 7.35 ohm by using tester Refer to Table 3-1. 	<ol style="list-style-type: none"> Connect the PF motor connector to the CN7 on the Main board. Replace the Printer mechanism with new one. If the problem is not solved, replace the Main board with new one.

Table 3-8. Paper jam error indication

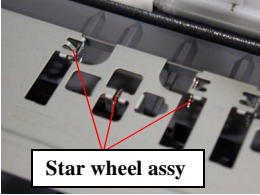
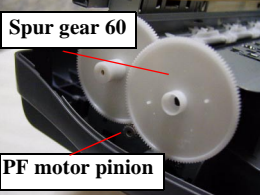
Step No.	Detail phenomenon	Check point	Remedy
1	Paper is not ejected completely and jammed around the Paper eject frame.	<ul style="list-style-type: none"> Check if the star wheel assembly is assembled in the Paper eject frame.  <p>Star wheel assy</p> <p>If it is no problem, proceed the next step.</p>	<ul style="list-style-type: none"> Replace the Paper eject frame with new one.
2	Ditto	<ul style="list-style-type: none"> Check if the Paper eject roller is rotating correctly.  <p>Spur gear 60</p> <p>PF motor pinion</p> <p>If it is no problem, proceed the next step.</p>	<ul style="list-style-type: none"> Set the tip of the Spur gear 60 to the PF motor pinion and assemble it correctly.

Table 3-9. Paper jam error indication

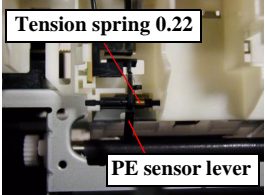
Step No.	Detail phenomenon	Check point	Remedy
3	Paper is loaded correctly from ASF. But, after complete the print job, paper jam indicated on the screen without any paper jam.	<ul style="list-style-type: none"> Check if the Torsion spring 0.22 comes off on the both PE sensor lever.  <p>Tension spring 0.22</p> <p>PE sensor lever</p> <p>If it is no problem, proceed the next step.</p>	<ul style="list-style-type: none"> If the Torsion spring 0.22 is not set on the correct position, set it correctly. If any paper dust is placed around the PE sensor lever, remove it.

Table 3-10. Paper jam error indication

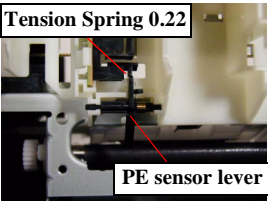
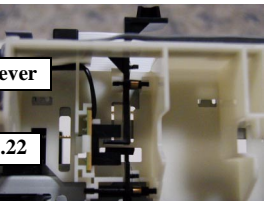
Step No.	Detail phenomenon	Check point	Remedy
4	The PF roller continues to turn when the printer's power is turned on.	<ol style="list-style-type: none"> 1. Check if the Torsion spring 0.22 comes off on the both PE sensor lever  2. Check if the Torsion spring 0.22 comes off on the both HP/IC sensor lever  	<ol style="list-style-type: none"> 1. If the Torsion spring 0.22 is not set on the correct position, set it correctly. If any paper dust is placed around the PE sensor lever, remove it. 2. If the Torsion spring 0.22 is not set on the correct position, set it correctly. If any paper dust is placed around the HP/IC sensor level, remove it. 3. Connect the CN4 connector cable to the CN4 on the Main board. 4. Replace the LD unit with new one. 5. If the problem is not solved, replace the Main board with new one.

Table 3-11. Paper Jam Error indication

Step No.	Detail phenomenon	Check point	Remedy
5	When the printer is turned on, the CR unit dose not move at all in the power on sequence.	<ol style="list-style-type: none"> 1. Check if the CR motor connector is connected CN12 on the Main board. 2. Check if the coil resistance of the CR motor is about 9.8 ohm by using the tester. Refer to Table 3-1. 	<ol style="list-style-type: none"> 1. Connect the CR motor connector to the CN12 on the Main board. 2. Replace the CR motor with new one. 3. If the problem is not solved, replace the Main board with new one.

Table 3-12. Ink Out error indication

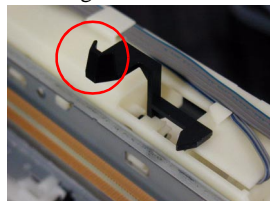
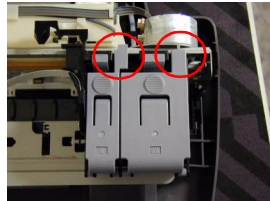
Step No.	Detail phenomenon	Check point	Remedy
1	"Ink Out error" is displayed regardless of whether a new ink cartridge is installed or not.	<ol style="list-style-type: none"> 1. Check if the HP/IC detection lever is damaged.  2. Check if the cover cartridge is damaged.  	<ol style="list-style-type: none"> 1. Replace the LD unit with new one. 2. Replace the cover cartridge with a new one.

Table 3-13. Multiple papers are always loaded

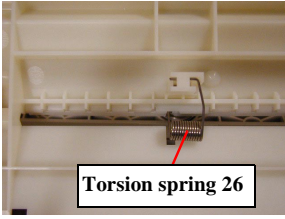
Step No.	Detail phenomenon	Check point	Remedy
1	Any error indication is not displayed on the monitor. But, multiple papers are always loaded from ASF.	Check if the Paper return plate is operating correctly in the ASF when the paper is loaded.	<ul style="list-style-type: none"> Assemble the torsion spring 26 in the ASF frame. 

Table 3-14. Paper is always loaded without any print job

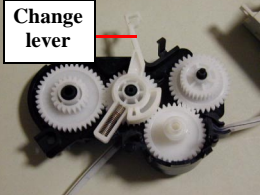
Step No.	Detail phenomenon	Check point	Remedy
1	Paper is always loaded from ASF without any print job. ASF hopper continue to flapping when the printer is turned on.	Check if the tip of the Change lever has any damage. 	Replace the Change lever (Printer mechanism) with new one.

Table 3-15. Fatal Error indication

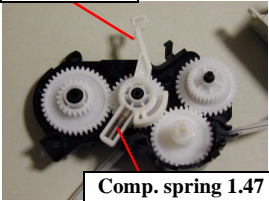
Step No.	Detail phenomenon	Check point	Remedy
4	When the printer is turned on, it sounds strange noise and the CR unit is stopped around the CR lock lever.	<ol style="list-style-type: none"> Check if the compression spring 1.47 is installed securely on the change lever.  Check if the PF motor is operated. Check the CN7 connector and the coil resistance for PF motor. If the CR lock lever is not released even if the PF motor rotate in the power on sequence, check if one of the gears has any damage in the PF motor torque transportation path. Refer to Figure 2-15. 	<ol style="list-style-type: none"> Install the compression spring 1.47 securely. Connect the PF motor cable to CN7 on the Main board. Replace the PF motor with new one. Replace the Printer mechanism with new one. If the problem is not solved, replace the Main board with new one.

Table 3-16. Paper is not ejected completely without any error indication

Step No.	Detail phenomenon	Check point	Remedy
1	Printing is normal. But, the paper is not ejected completely and the bottom area stay around the Paper eject frame.	<ol style="list-style-type: none"> 1. Check if the Paper eject roller rotate when the paper is ejected. 2. Check if the Paper eject frame is secured with the three fixing screws to the Main frame. 	<ol style="list-style-type: none"> 1. Assemble the Spur gear 60 to the PF motor pinion. 2. Secure the Front frame with the two fixing screws to the Main frame.

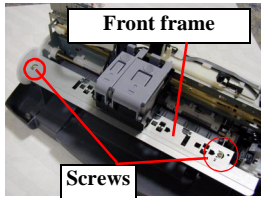
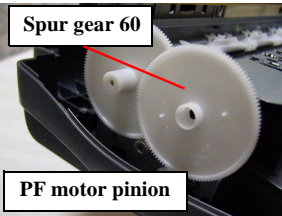


Table 3-17. Dot missing occur and it is not recovered with CL

Step No.	Detail phenomenon	Check point	Remedy
1	In the CL sequence, the pump unit seems work correctly. But, ink is not ejected to the waste ink pad at all. Moreover, any ink is not absorbed from the head to the cap.	<ol style="list-style-type: none"> 1. Check if ink is ejected to the waste ink pad via pump unit in the CL sequence. 2. Check if there is any foreign material around the seal rubber parts on the cap assembly. 3. Check if any damage is observed around the seal rubber parts on the cap assembly. 4. Check if the compression spring is assembled in the Cap assembly correctly. 	<ol style="list-style-type: none"> 1. If ink is not ejected at all to the waste ink pad in the CL sequence, proceed the following check point 2). 2. Remove the foreign material around the seal rubber parts. 3. Replace the Printer mechanism with new one. 4. Replace the Printer mechanism with new one.

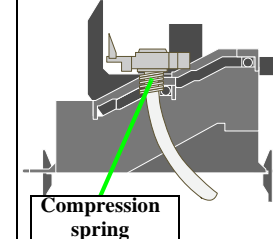
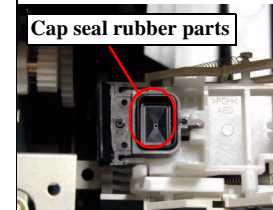


Table 3-18. Dot missing occur and it is not recovered with CL

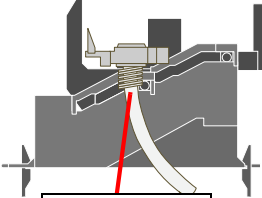
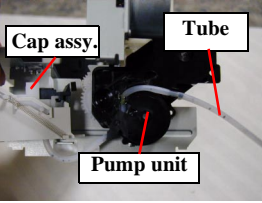
Step No.	Detail phenomenon	Check point	Remedy
1	In the CL sequence, the pump unit seems work correctly. But, any ink is not ejected to waste ink pad. Moreover, any ink is not absorbed from the head to the cap.	<p>5. Check if the Pump tube is connected to the bottom of the Cap assembly correctly</p>  <p>Pump tube connection point</p> <p>6. Check if the pump tube has a little slack between the Cap assembly and the pump unit when the Cap assembly is slide up completely.</p>  <p>Cap assy. Tube Pump unit</p>	<p>5. Replace the Printer mechanism with new one.</p> <p>6. Pump unit may coil the pump tube inside the unit. In this case, pull out the coiled tube from the pump unit carefully. After that, connect the pump tube to the Cap assembly after placing the tube correctly.</p> <p>7. If the problem is not solved, replace the Printer mechanism with new one.</p>

Table 3-19. Dot missing occur and it is not recovered with CL

Step No.	Detail phenomenon	Check point	Remedy
2	In the CL sequence, ink is ejected to the Waste ink pad (this means pump unit & cap unit are working correctly). But, the dot missing is not solved at the specific nozzles even if the several CLs are performed.	<p>1. Check if the segment in the nozzle check patter is reduced every CL & Nozzle check pattern printing.</p> <p>2. Check if any damage is observed on the Head FFC.</p>	<p>1. Replace the I/C with new one in the I/C replacement sequence.</p> <p>2. Replace the Head FFC with the new one.</p> <p>3. Replace the printhead with new one.</p>
3	In the CL sequence, ink is ejected to the Waste ink pad. But, dot missing is occurred on all nozzle in the printing and is not solved in the several CLs.	<p>1. Check if the Head FFC is connected to the CN9 on the Main board or Head FFC.</p>	<p>1. Connect the Head FFC securely to the CN9 on the Main board or Printhead.</p> <p>2. Replace the Printhead with new one.</p> <p>3. Replace the Main board with new one.</p>

Table 3-20. Print quality is not good

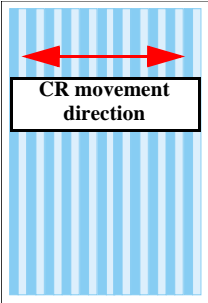
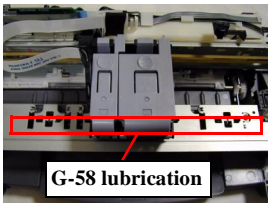
Step No.	Detail phenomenon	Check point	Remedy
1	<p>Vertical banding is appeared against the CR movement direction. And it looks like uneven printing.</p>  	<ol style="list-style-type: none"> 1. Check if each segment is printed correctly in the nozzle check pattern. 2. Check if the CR rail on the main frame is not extremely dirty, etc. 3. Check if the surface of the CR sliding portion on the Paper eject frame has enough oil. 4. Check if the surface of the Paper eject frame is flat. 	<ol style="list-style-type: none"> 1. Perform the CL and check the nozzle check pattern. 2. Clean the CR rail on the main frame and lubricate G-58. 3. Clean the surface of the CR sliding portion on the Paper eject frame and lubricate specific amount of the G-58. 4. Replace the Paper eject frame with new one.

Table 3-21. Print quality is not good

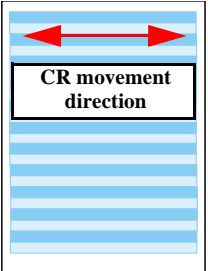
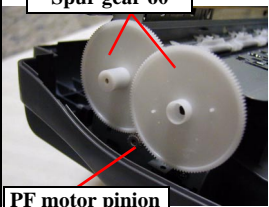
Step No.	Detail phenomenon	Check point	Remedy
1	Ditto		<ol style="list-style-type: none"> 5. Replace the following parts. <ul style="list-style-type: none"> • CR motor • CR timing belt • Compression spring 11.8
2	<p>Micro banding appears horizontally against the paper feeding direction and it appears with the same width.</p>  	<ol style="list-style-type: none"> 1. Check if each segment is printed correctly in the nozzle check pattern. 2. Check if the suitable paper is used according to the printer driver setting. 3. Check if the Paper feed roller is dirty. 4. Check if the following parts do not have any damage. 	<ol style="list-style-type: none"> 1. Perform the CL and check the nozzle check pattern. by using the Adjustment program. 2. Use the suitable paper according to the printer driver setting. 3. Clean the surface of the PF roller carefully with the soft brush 4. Replace the Printer mechanism with new one. 5. Replace the Printhead with new one.

Table 3-22. Print quality is not good

Step No.	Detail phenomenon	Check point	Remedy
3	Printing is blurred	<ol style="list-style-type: none"> 1. Check if the suitable paper is used according to the printer driver setting. 2. Check if the correct head ID is stored in the EEPROM by using the Adjustment program. 	<ol style="list-style-type: none"> 1. Use the suitable paper according to the driver setting. 2. Input 6 digits code of the head ID into the EEPROM by using the Adjustment program.
4	Ink stains the paper	<ol style="list-style-type: none"> 1. Check if the following parts are stained with ink. <ul style="list-style-type: none"> • PF roller • Paper guide front • Paper eject roller. 2. Check if there is some ink drops around the backside of the printhead. 3. If the bottom area of the printed paper has ink stain, check if the Paper eject frame is secured with three screws. 4. If the bottom area of the printed paper has ink stain, check if the Paper eject frame is bent upward. 	<ol style="list-style-type: none"> 1. Clean the ink stained parts with soft cloth. 2. Wipe off the ink drop with the soft cloth carefully. 3. Secure the screws fixing the Paper eject frame. 4. Replace the Paper eject frame with new one.

CHAPTER

4

DISASSEMBLY AND ASSEMBLY

4.1 Overview

This section describes procedures for disassembling the main components of the Stylus C40UX/C40SX/C20UX/C20SX. Unless otherwise specified, disassembly units or components can be reassembled by reversing the disassembly procedure. Things, if not strictly observed, that could result in injury or loss of life are described under the heading “Warning”. Precautions for any disassembly or assembly procedures are described under the heading “CAUTION”. Chips for disassembling procedures are described under the heading “CHECK POINT”.

If the assembling procedure is different from the reversed procedure of the disassembling, the procedure is described under the heading “REASSEMBLY”.

Any adjustments required after disassembling the units are described under the heading “ADJUSTMENT REQUIRED”. When you have to remove any units or parts that are not described in this chapter, refer to the exploded diagrams in the appendix.

Read precautions described in the next section before starting.

4.1.1 Precautions

See the precautions given under the handling “WARNING” and “CAUTION” in the following column when disassembling or assembling the Stylus C40UX/C40SX/C20UX/C20SX.



- **Disconnect the power cable before disassembling or assembling the printer.**
- **If you need to work on the printer with power applied, strictly follow the instructions in this manual.**
- **Wear protective goggles to protect your eyes from ink. If ink gets in your eye, flush the eye with fresh water and see a doctor immediately.**
- **Always wear gloves for disassembly and reassembly to avoid injury from sharp metal edges.**
- **To protect sensitive microprocessors and circuitry, use static discharge equipment, such as anti-static wrist straps, when accessing internal components.**
- **Never touch the ink or wasted ink with bare hands. If ink comes into contact with your skin, wash it off with soap and water immediately. If irritation occurs, contact a physician.**
- **When a lithium battery is installed on the main board of this printer, make sure to observe the following instructions when serving the battery:**
 1. Keep the battery away from any metal or other batteries so that electrodes of the opposite polarity do not come in contact with each other.
 2. Do not heat the battery or put it near fire.
 3. Do not solder on any part of the battery. (Doing so may result in leakage of electrolyte from the battery, burning or explosion. The leakage may affect other devices close to the battery.)
 4. Do not charge the battery. (An explosion may be generated inside the battery, and cause burning or explosion.)
 5. Do not dismantle the battery. (The gas inside the battery may hurt your throat. Leakage, burning or explosion may also be resulted.)
 6. Do not install the battery in the wrong direction. (This may cause burning or explosion.)
- **Danger of explosion if the battery is incorrectly replaced. Replace only with the same or equivalent type recommended by the manufacture. Dispose the used batteries according to government’s law and regulations.**

WARNING

- Avant de commencer, assurez vous que l'imprimante soit éteinte et que le cordon d'alimentation soit débranché.
- Lorsque vous changez la pile au lithium, assurez vous que la nouvelle respecte bien les caractéristiques requises.
- Lorsque que vous installez la pile au lithium, faites attention à l'insérer dans le bon sens en respectant la polarité.
- Veillez à jeter les piles usagées selon le règlement local.
- Ne rechargez pas les piles au lithium.

CAUTION

Risque d'explosion si la pile est remplacée incorrectement. Ne remplacer que par une pile du même type ou d'un type équivalent recommandé par le fabricant. Éliminer les piles déchargées selon les lois et les règles de sécurité en vigueur.

WARNING

- When working on the FUSER ASSY or nearby parts, be sure to wait until the temperature of the parts cool down to a safe level. Wait at least 40 minutes before you start working on the printer.
- Do not expose yourself to the laser beam to prevent injury (blindness).
- Understand how the laser beam functions and take maximum precautions not to injure yourself or anyone around you.

CAUTION

- Never remove the ink cartridge from the carriage unless this manual specifies to do so.
- When transporting the printer after installing the ink cartridge, be sure to pack the printer for transportation without removing the ink cartridge.
- Use only recommended tools for disassembling, assembling or adjusting the printer.
- Observe the specified torque when tightening screws.
- Apply lubricants and adhesives as specified. (See Chapter 6 for details.)
- Make the specified adjustments when you disassemble the printer. (See Chapter 5 for details.)
- When assembling, if an ink cartridge is removed and needs to be installed again, be sure to install a new ink cartridge because of the following reasons;
 1. Once the ink cartridge mounted on the printer is removed, air comes in and creates bubbles in the cartridge. These bubbles clog ink path and cause printing malfunction.
 2. If an ink cartridge in use is removed and is reinstalled, ink quantity will not be detected correctly since the counter to check ink consumption is cleared.
- Because of the reasons above, make sure to return the printer to the user with a new ink cartridge installed.

4.1.2 Tools






Use only specified tools to avoid damaging the printer.

Table 4-1.

Name	Supplier	Parts No.
Phillips Screw Driver (No.1)	EPSON	B743800100
Phillips Screw Driver (No.2)	EPSON	B743800200
Nipper	EPSON	B740500100
Tweezers	EPSON	B741000100

4.1.3 Screws

Table 4-2.

No.	Name and Specification	Outward Form
1	CBS 3x6	
2	CBP 3x8	
3	CBS (P2) 3x6	
4	CBS 3x8	
5	C.P.F.S-Tite 3x12	

4.1.4 Work Completion Check

If any service is made to the printer, use the checklist shown below to confirm all works are completed properly and the printer is ready to be returned to the user.

Table 4-3. Work Completion Check

Classification	Item	Check Point	Status	
Main Unit	Self-test	Is the operation normal?	<input type="checkbox"/> Checked <input type="checkbox"/> Not necessary	
	On-line Test	Is the printing successful?	<input type="checkbox"/> Checked <input type="checkbox"/> Not necessary	
	Printhead	Is ink discharged normally from all the nozzles?	<input type="checkbox"/> Checked <input type="checkbox"/> Not necessary	
	Carriage Mechanism		Does it move smoothly?	<input type="checkbox"/> Checked <input type="checkbox"/> Not necessary
			Is there any abnormal noise during its operation?	<input type="checkbox"/> Checked <input type="checkbox"/> Not necessary
			Is there any dirt or foreign objects on the CR Guide Shaft?	<input type="checkbox"/> Checked <input type="checkbox"/> Not necessary
			Is the CR Motor at the correct temperature? (Not too heated?)	<input type="checkbox"/> Checked <input type="checkbox"/> Not necessary
	Paper Feeding Mechanism		Is paper advanced smoothly? • No paper jamming? • No paper skew? • No multiple feeding? • No abnormal noise?	<input type="checkbox"/> Checked <input type="checkbox"/> Not necessary
			Is the PF Motor at correct temperature?	<input type="checkbox"/> Checked <input type="checkbox"/> Not necessary
			Is the paper path free of any obstructions?	<input type="checkbox"/> Checked <input type="checkbox"/> Not necessary
	Adjustment	Specified Adjustment	Are all the adjustment done correctly?	<input type="checkbox"/> Checked <input type="checkbox"/> Not necessary

Table 4-3. Work Completion Check (continued)

Classification	Item	Check Point	Status
Lubrication	Specified Lubrication	Are all the lubrication made at the specified points?	<input type="checkbox"/> Checked <input type="checkbox"/> Not necessary
		Is the amount of lubrication correct?	<input type="checkbox"/> Checked <input type="checkbox"/> Not necessary
Packing	Ink Cartridge	Are the ink cartridges installed correctly?	<input type="checkbox"/> Checked <input type="checkbox"/> Not necessary
	Protective Materials	Have all relevant protective materials been attached to the printer?	<input type="checkbox"/> Checked <input type="checkbox"/> Not necessary
Others	Attachments, Accessories	Have all the relevant items been included in the package?	<input type="checkbox"/> Checked <input type="checkbox"/> Not necessary

4.2 Disassembly

The flowchart below shows step-by-step disassembly procedures. When disassembling each unit, refer to the page number shown in the figure.

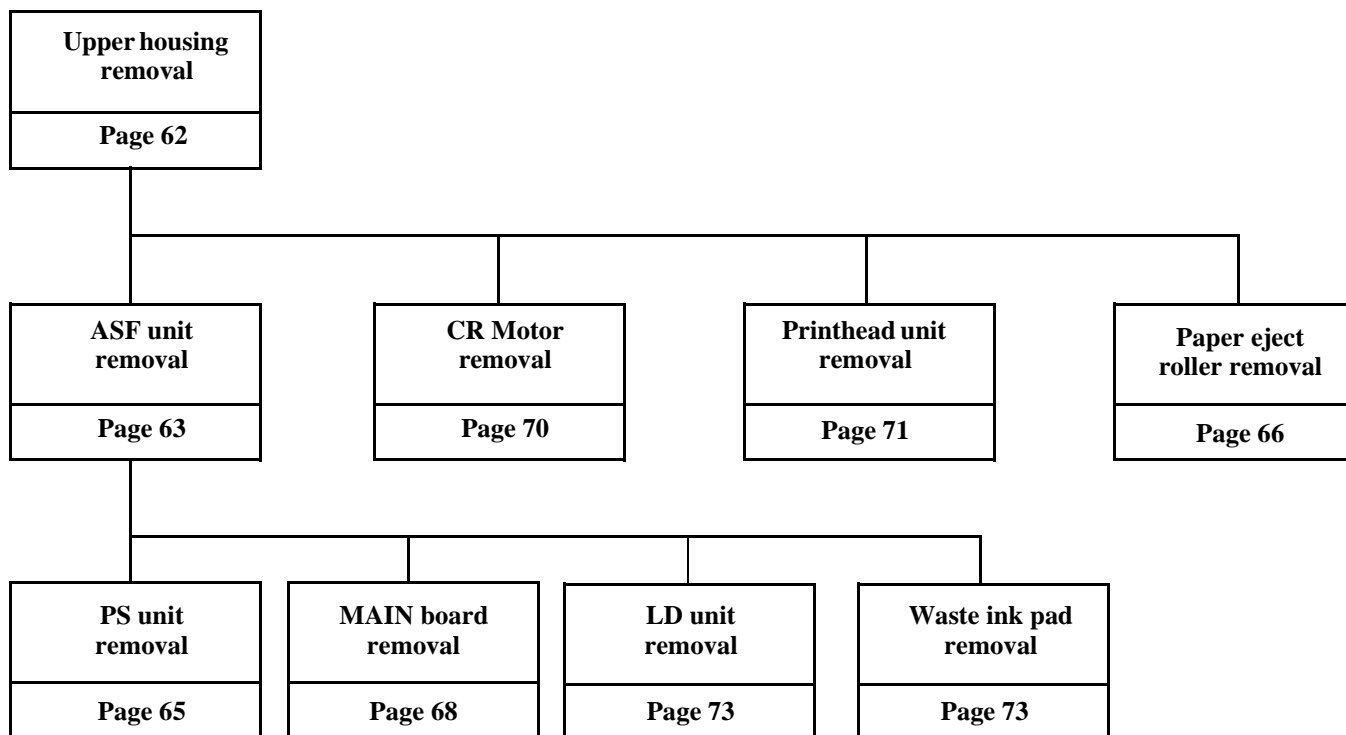


Figure 4-1. Disassembling Flowchart

4.2.1 Upper housing removal

1. Move the edge guide to the right until it stops moving. Make sure the edge guide is in the upper housing's notch position.



Figure 4-2. Position of Edge guide

2. Remove the 2 hooks at the front using a precision screwdriver (-).



The printer should not turn when the front 2 hooks are removed.

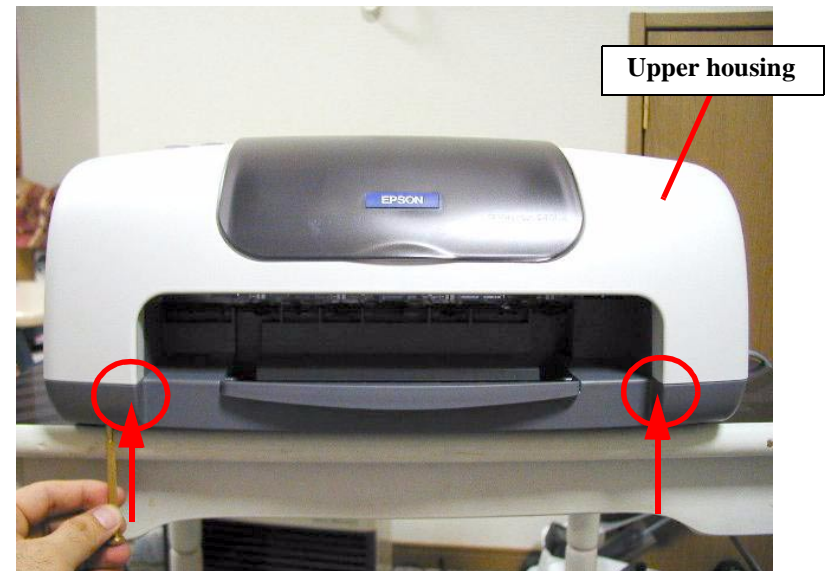


Figure 4-3. Removing the front hook

- Remove the 2 hooks on the sides by pushing the tops of the hooks up.

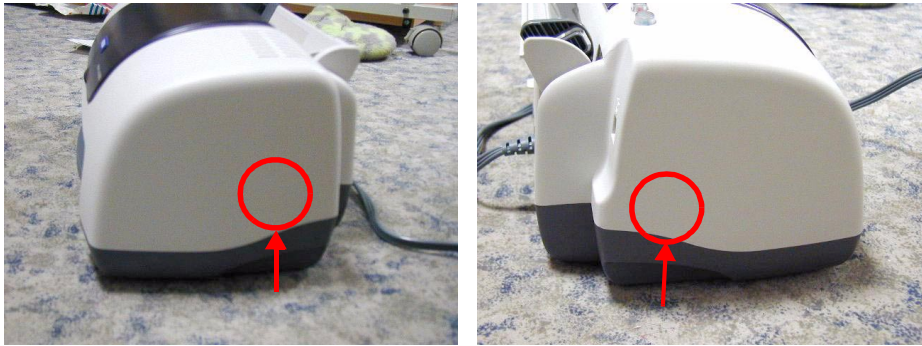


Figure 4-4. Removing the side hook

- Remove the 3 hooks at the back using a (-) screwdriver or similar tool.

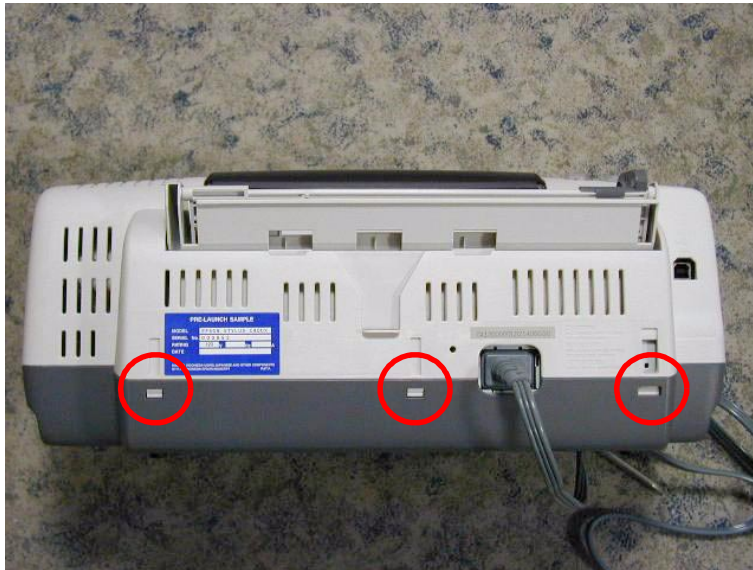


Figure 4-5. Removing the back hook

4.2.2 ASF unit removal

- Remove the upper housing. (Refer to Section 4.2.1)
- Take out the three screws.

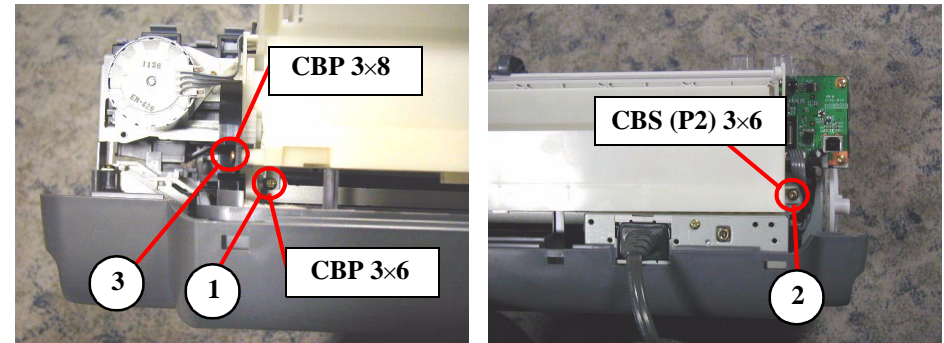


Figure 4-6. Removing the ASF unit

- Pull the ASF unit toward the rear and remove it.



- When installing the ASF unit, install the spring in the guide, then install it while supporting it by hand.

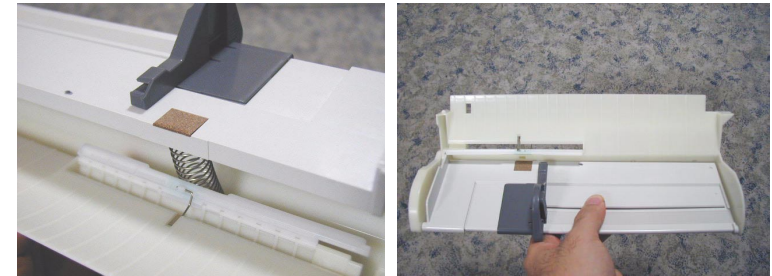


Figure 4-7. reassembling the ASF unit

- When reassembling the ASF unit tighten screws from lower numbers in Figure4-6.
- Tightening Torque for screw
 - C.B.S 3x6 : 9+/-1 kgf.cm
 - C.B.S (P2) 3x6 : 9+/-1 kgf.cm
 - C.B.P 3x8 : 6+/-1 kgf.cm

4.2.3 Waste ink pad removal

1. Remove the upper housing. (Refer to Section 4.2.1)
2. Remove the ASF unit. (Refer to Section 4.2.2)
3. Remove the Waste ink pad.



When the Waste ink pad is replaced with a new one, following service item is required.

- Waste ink counter reset operation. (Refer to Section 5.1.12)

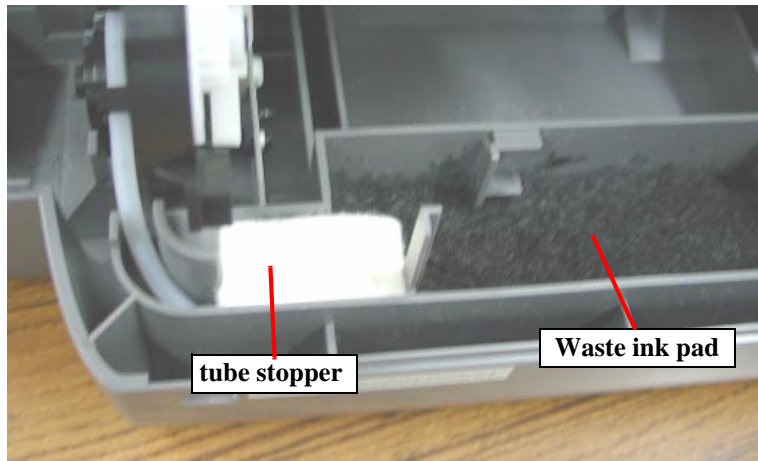


Figure 4-8. Removing the Waste ink pad



- When assembling the Waste ink pad, be sure to set the tip of the ink tube in the correct position of the Waste ink pad. Otherwise it will cause ink leakage.

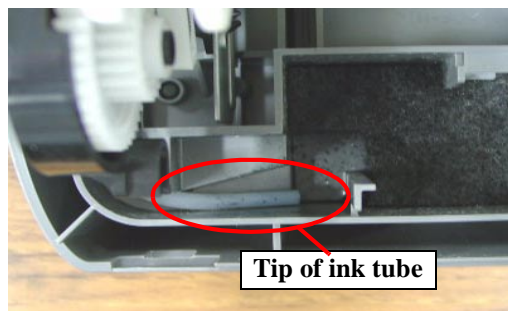


Figure 4-9. Tip of ink tube setting position

4.2.4 PS unit removal

1. Remove the upper housing. (Refer to Section 4.2.1)
2. Remove the ASF unit. (Refer to Section 4.2.2)
3. Disconnect the cable from the connector (CN2) on the main board using tweezers, etc.
4. Take out the 2 screws.

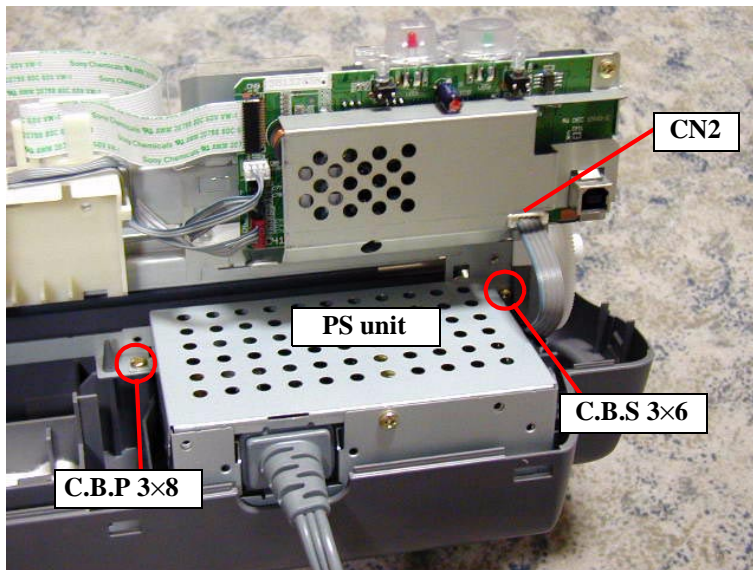


Figure 4-10. Removing the PS unit

5. Pull the PS unit out while lifting up on it.



- When installing the PS unit, make sure the claws are attached to the hooks on the lower housing.

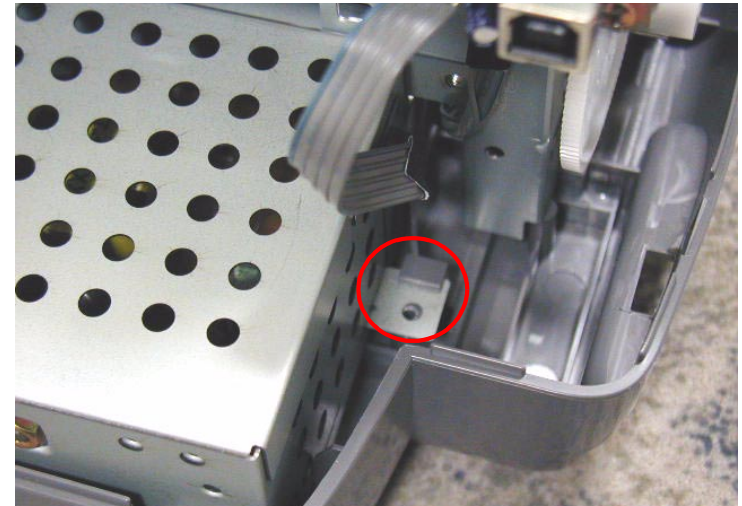


Figure 4-11. Reassembling the PS unit

- Blue line marking on PS cable should set top in No.1 of connector on the MAIN board.

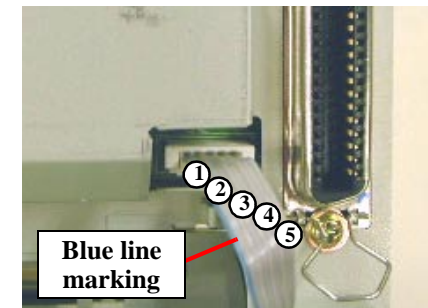


Figure 4-12. Connecting the PS cable (CN2)

- Tightening Torque for screw

- C.B.S 3x6	: 6+/-1 kgf.cm
- C.B.P 3x8	: 6+/-1 kgf.cm

4.2.5 Paper eject roller removal

1. Remove the upper housing. (Refer to Section 4.2.1)
2. Grip the dowel pin of the PE roller's gear, turn it clockwise and release the carriage lock.

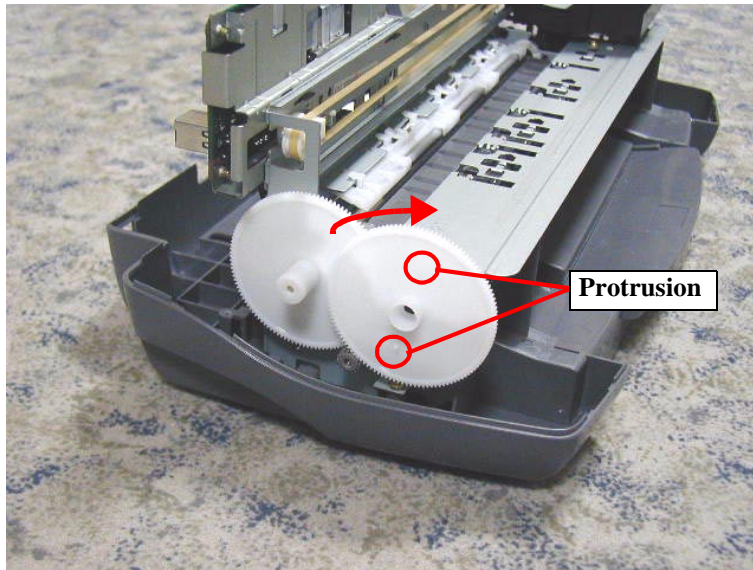


Figure 4-13. Releasing the carriage lock

3. Move the carriage to the center.

4. Take out the two screws.

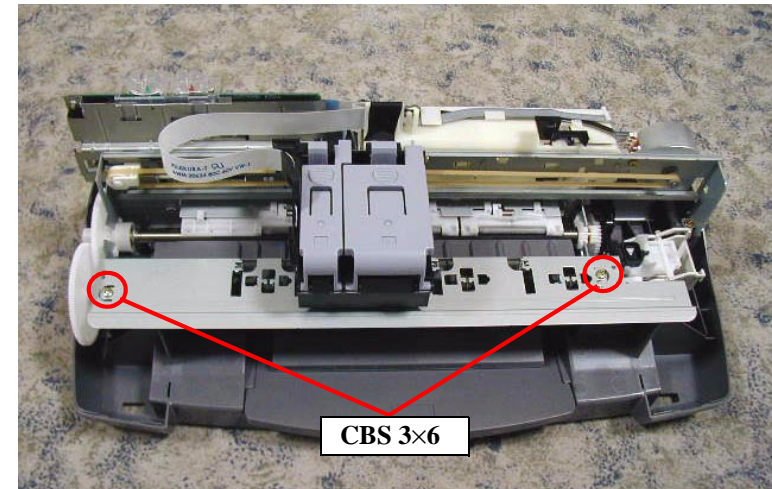


Figure 4-14. Take out the screw

5. Return the carriage to the home position, then remove the Front Frame.

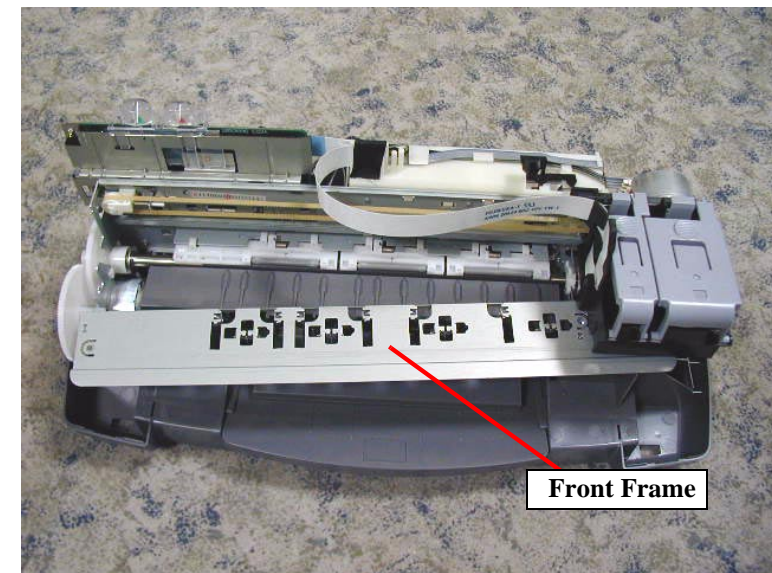


Figure 4-15. Removing the Front Frame

- Slide the PE roller to the left side, then remove the claw extending from the lower housing.

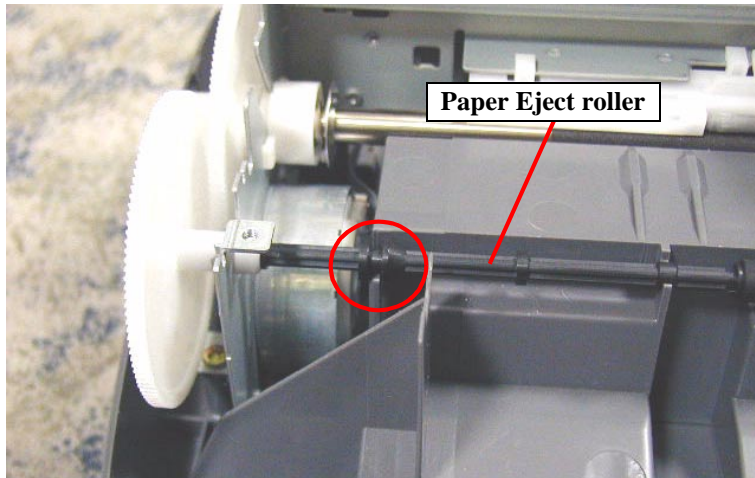


Figure 4-16. Releasing the claw extending

- Remove the gear from the frame, then remove the Paper eject roller.

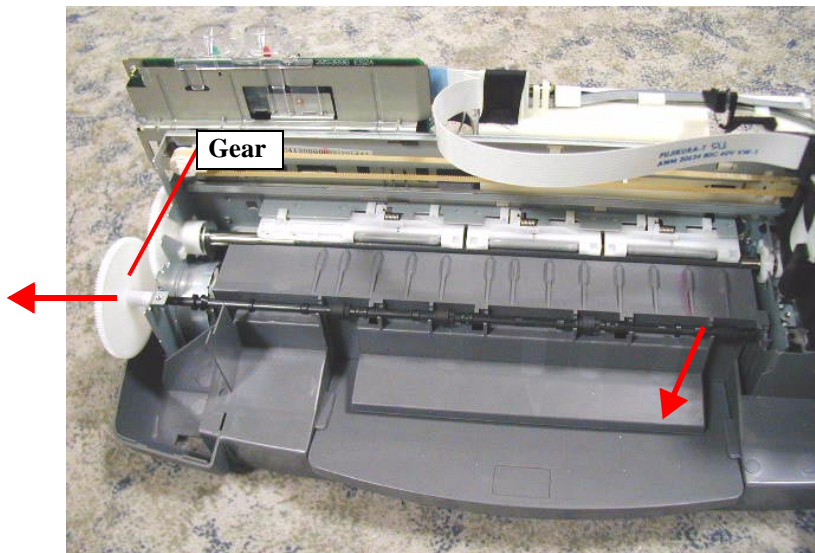


Figure 4-17. Removing the Paper eject roller



- If the Paper eject roller gear and Paper eject roller shaft are removed or , make sure that neither of the Paper eject roller shaft hooks is damaged. If either of the hooks is damaged, it should be replaced with a new one.

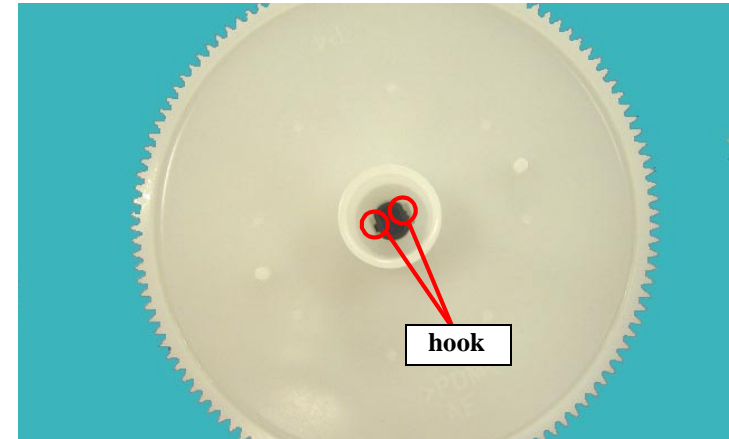


Figure 4-18. Hook of Paper eject roller



- Tightening Torque for screw
- C.B.S 3x6 screw for Front frame : 6+/-1 kgf.cm

4.2.6 MAIN board removal

1. Remove the upper housing. (Section 4.2.1 Upper housing removal)
2. Remove the ASF unit. (Section 4.2.2 ASF unit removal)
3. Remove the PS unit. (Section 4.2.4 PS unit removal)
4. Remove the two hooks, then remove the Switch cover.

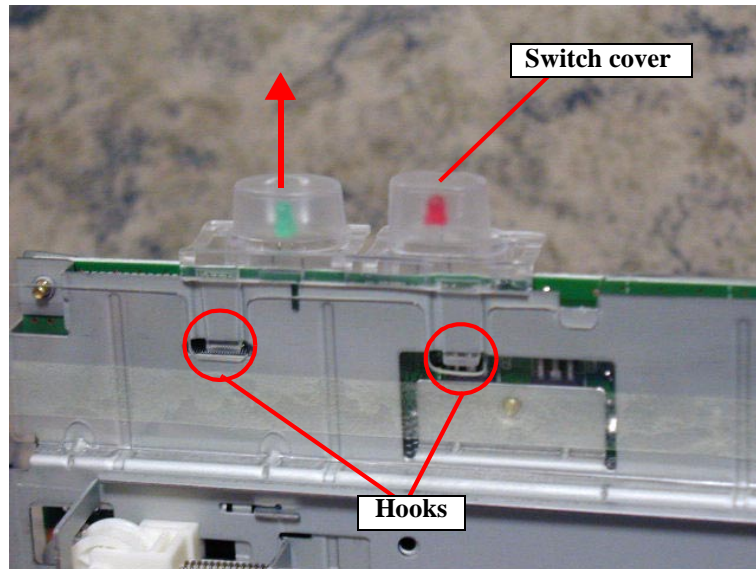
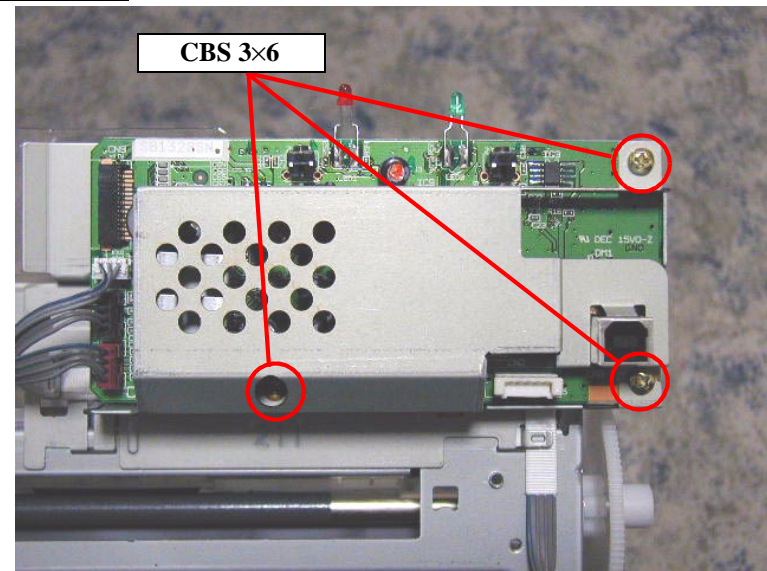


Figure 4-19. Removing the Switch cover

5. Remove the three screws, then remove the shield cover.

USB Type



Parallel Type

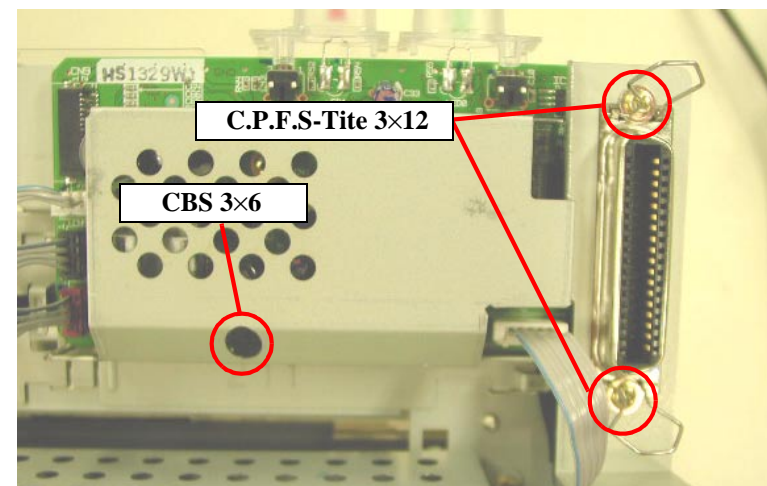


Figure 4-20. Removing the Shield cover

6. Disconnect the four connectors (CN9, CN4, CN7, CN12).

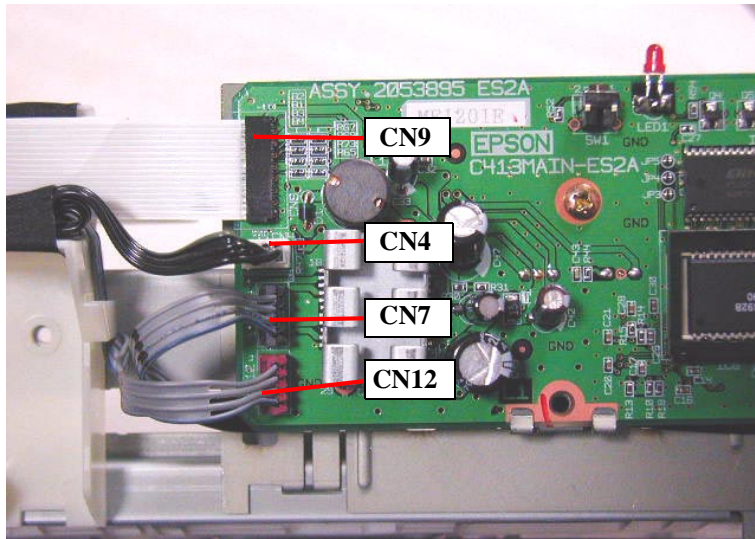


Figure 4-21. Disconnecting the connectors

7. Take out the 1 screw.

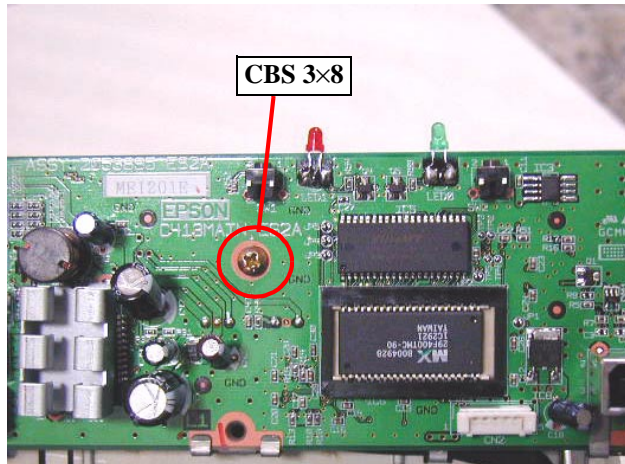


Figure 4-22. Removing the MAIN board

8. Lift the MAIN board up and remove it.



Tightening Torque for screw

- USB Type
 - C.B.S 3x6 screw : 9+/-1 kgf.cm
 - C.B.S 3x8 screw : 9+/-1 kgf.cm
- Parallel Type
 - C.B.S 3x6 screw : 9+/-1 kgf.cm
 - C.P.F.S-Tite 3x12 screw : 9+/-1 kgf.cm
 - C.B.S 3x8 screw : 9+/-1 kgf.cm



When replacing the Main board with a new one, perform the following service items.

- Before removing the Main Board, connect the parallel cable or USB cable and try to read out the following data by using the Adjustment program. If this operation succeeds, replace the Main board and write the read out data to the new Main board through the Adjustment program. (Refer to Section 5.1.14)
 - 1) I/C Ink consumption counter.
 - 2) Waste ink drain pad counter.
 - 3) EEPROM Initial setting
 - 4) Head ID input
 - 5) Top margin adjustment
 - 6) Bi-D adjustment

In case the above mentioned data are not able to be read out from the defective Main board, perform the following service items.

- Replace the both ink cartridges with a brand new one.
- Replace the Waste ink pad with a new one.
- Reset the Ink pad counter
- Input the EEPROM initial setting value
- Input the Head ID
- Adjust the Top margin
- Adjust the Bi-D alignment.

4.2.7 CR motor removal

1. Remove the upper housing. (Section 4.2.1 Upper housing removal)
2. Move the carriage to the center.
3. Press on the driven pulley and loosen the timing belt, then remove the timing belt from the CR pinion gear.

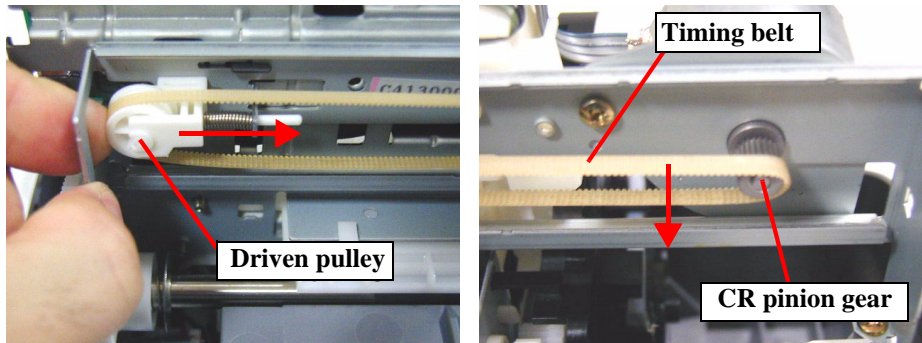


Figure 4-23. Removing the Timing belt

4. Take out the screw, then remove the CR motor from the frame.

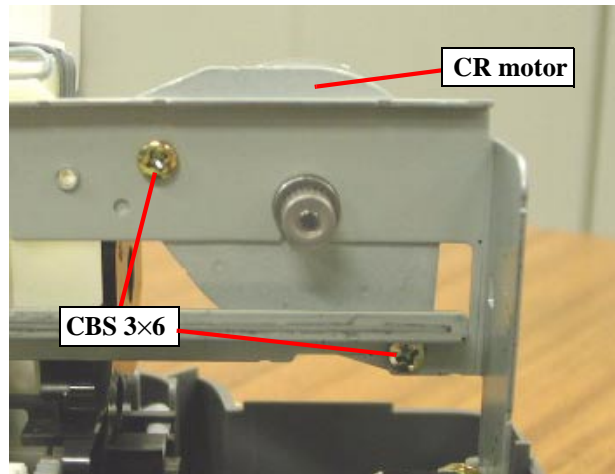


Figure 4-24. Removing the CR motor

5. Disconnect connector CN7 from the MAIN board then disconnect the cable.



- When reassembling the CR motor, it contact the lib of Main frame after turning clockwise.

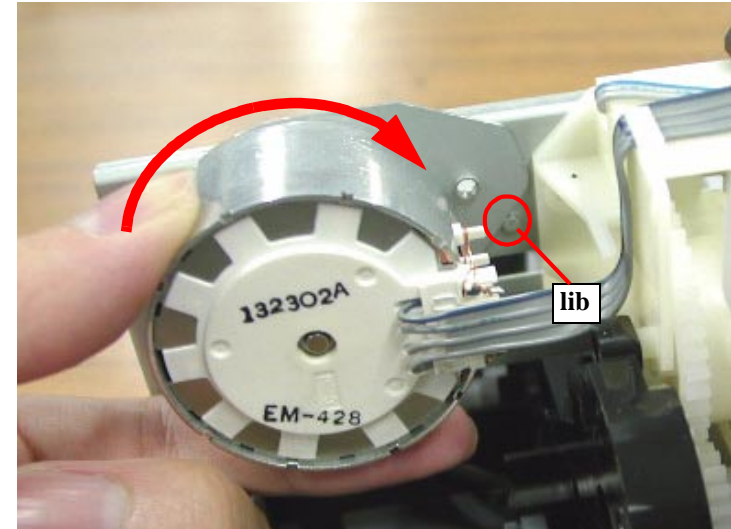


Figure 4-25. Reassembling the CR motor

- Tightening Torque for screw
- C.B.S 3x6 screw : 9+/-1 kgf.cm



- The Bi-D adjustment is required when the CR motor is removed or replaced. Refer to Table 5-1

4.2.8 Printhead unit removal

1. Remove the upper housing. (Section 4.2.1 Upper housing removal)
2. Remove the ink cartridges.
3. Move the carriage to the center.
4. Press on the driven pulley and loosen the timing belt, then remove the timing belt from the CR pinion gear.

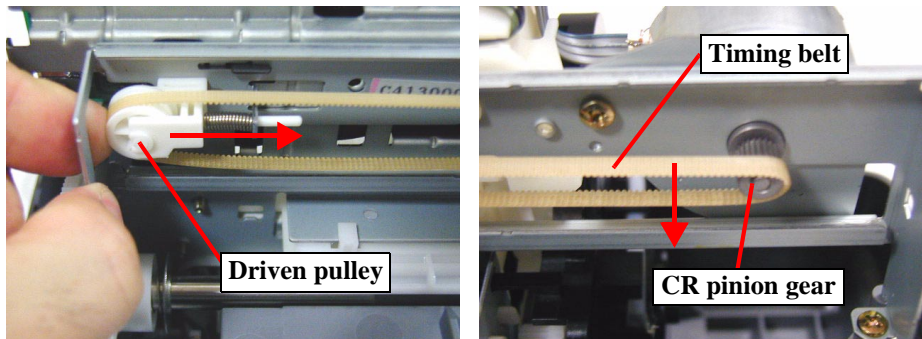


Figure 4-26. Removing the Timing belt

5. Disconnect the FFC from the carriage unit.

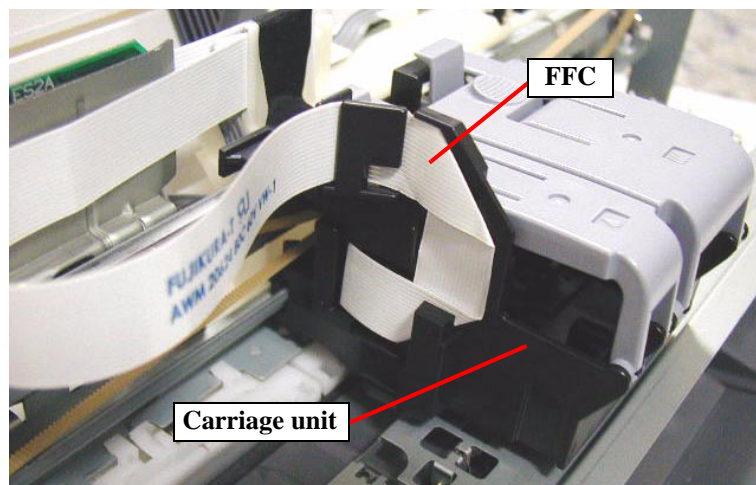


Figure 4-27. Disconnecting the FFC

6. Press on the left and right inside of the carriage unit, then pull the unit forward and remove the cover.

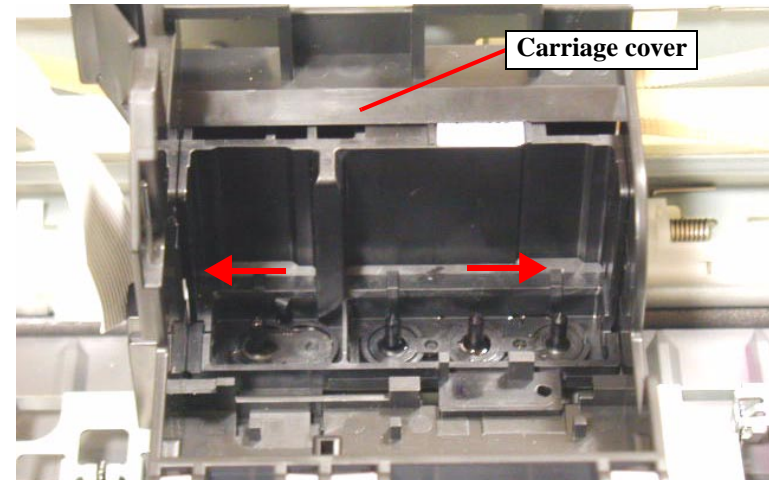


Figure 4-28. Removing the Carriage cover

7. Lift the Printhead unit up and remove it.

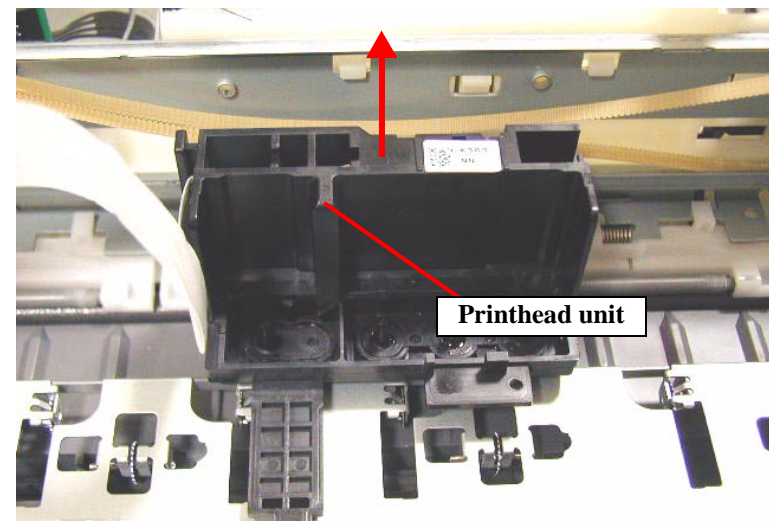


Figure 4-29. Removing the Printhead unit

8. Disconnect the FFC from the connector.

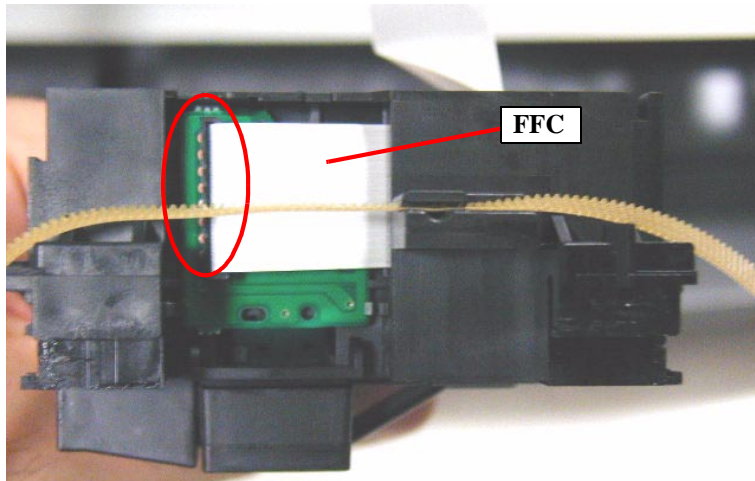


Figure 4-30. Disconnecting the FFC



When the Printhead is replaced with a new one, following adjustments must be performed in the order below: Refer to Table 5-1

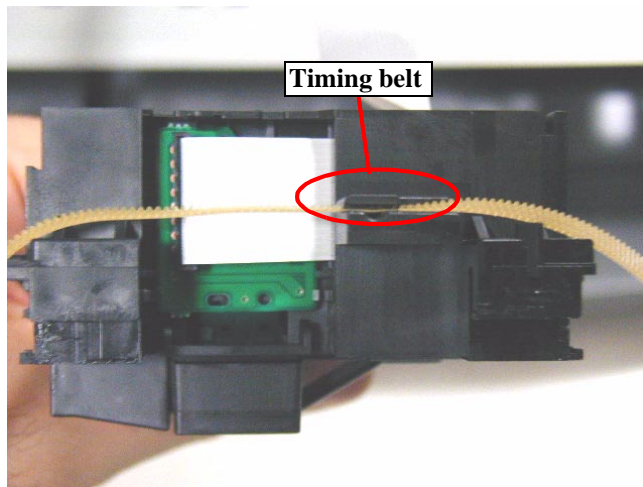
1. Initial ink charge
2. Head ID input
3. Bi-D adjustment

When the Printhead is removed and reinstalled, only the following adjustment is required. Refer to Table 5-1

1. Head cleaning
2. Bi-D adjustment



- If the Carriage unit is disassembled or replaced with a new one, make sure that the Carriage timing belt is set in the assembling groove correctly as following figure.



4.2.9 LD unit removal

1. Remove the upper housing. (Section 4.2.1 Upper housing removal)
2. Remove the ASF unit. (Section 4.2.2 ASF unit removal)
3. Disconnect the cables which are connected to the LD unit.
4. Disconnect connector CN4 form the MAIN board.

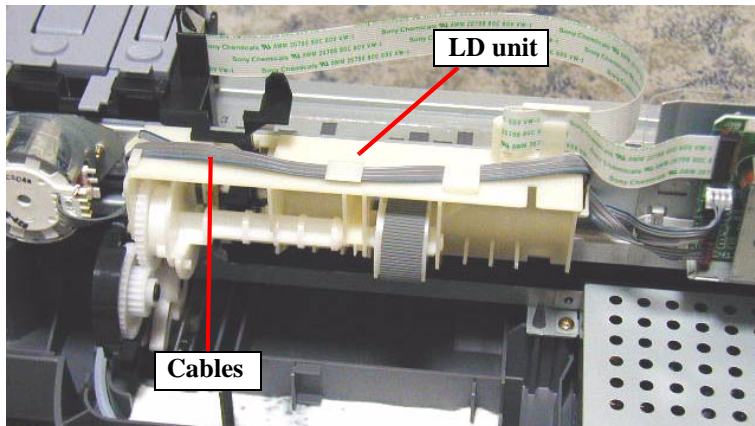


Figure 4-31. Disconnecting the Cables

5. Push the two hooks on the LD unit, then lift it up and remove hook of pump unit

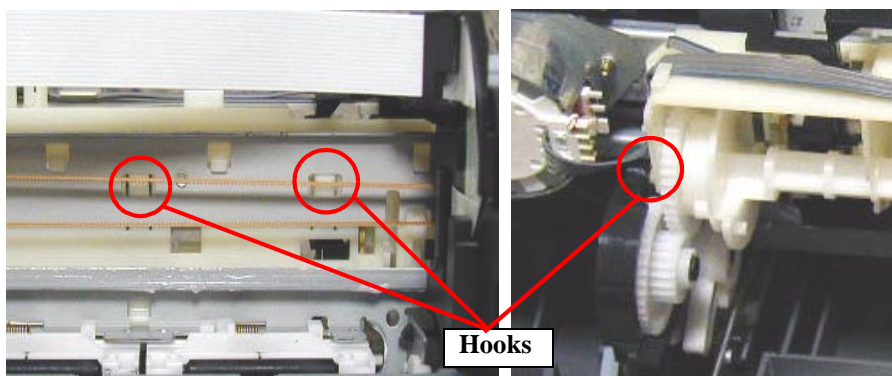


Figure 4-32. Removing the LD unit



- When reassembling the LD unit, make sure that seven hooks are set to the Main frame.

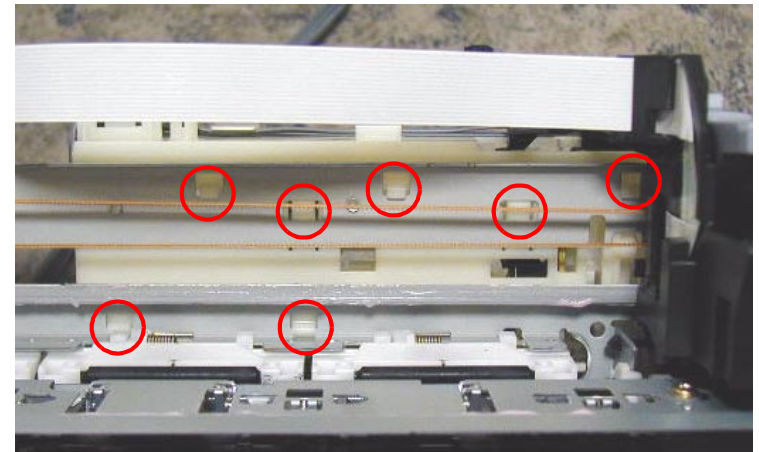


Figure 4-33. Setting seven hooks

4.2.10 Printer mechanism removal

1. Remove the upper housing. (Refer to Section 4.2.1)
2. Remove the ASF unit. (Refer to Section 4.2.2)
3. Remove the PS unit. (Refer to Section 4.2.4)
4. Remove the Printhead unit. (Refer to Section 4.2.8)
5. Remove the Paper eject roller. (Refer to Section 4.2.5)

ADJUSTMENT
REQUIRED



When the Printer mechanism with a new one, following adjustments must be performed in the order below: Refer to Table

5-1

1. Initial ink charge
2. Head ID input
3. Top margin adjustment
4. Bi-D adjustment

CHAPTER

5

ADJUSTMENT

5.1 Overview

This section describes the procedure for adjustments required when the printer is disassembled and assembled for repair or service.

5.1.1 Required Adjustment

Table 5-1 lists all the necessary adjustments for this printer. If any service listed in this table is carried out, all adjustments corresponding to that service item should be performed to ensure proper operation of the printer.

Table 5-1. Required Adjustment

Performance Priority	1	2	3	4	5	6	7
Replacing parts/ Service item	EEPROM initial setting	Ink pad Counter reset	Initial Ink Charge	Head ID Setting	Top margin Adjustment	Bi-D Adjustment	USB ID Input
Replacing the Main Board	①	②	NA	③	④	⑤	⑥
Removing the Printhead unit	NA	NA	NA	NA	NA	①	NA
Replacing the Printhead unit	NA	NA	①	②	NA	③	NA
Replacing the CR motor	NA	NA	NA	NA	NA	①	NA
Replacing the Printer mechanism	NA	NA	①	②	③	④	NA
Replacing the Waste drain ink pad	NA	①	NA	NA	NA	NA	NA

NOTE: • “O”: Required Adjustment. The number in the circle shows the required adjustment order.

• “NA”: Not applicable.

• Following adjustments are not required on this product.

-Platen Gap adjustment

-Head Angular adjustment.

• When the Main board is replaced with new one, you may have to replace the following parts also in case the EEPROM parameter back up function is not available on the defective main board.

* Waste drain ink pad

* Both Black & Color Ink Cartridge

This section describes the detailed procedures of each adjustment by Adjustment Program.

In this printer, it is necessary to set the adjusting information for each printer mechanism in order to maintain consistent printing function and quality, eliminating differences of each printer mechanism's characteristics. Therefore, in case that the combination of the printer mechanism and main board changes or the print head is replaced during the repair service, you must set and save the correct information to the MAIN board, using the exclusive adjustment program.



In case any parts is removed and assembled on the repair product while running the Adjustment program, turn off the printer certainly.

5.1.2 Adjustment Program Initial Setting menu

You have to input the following four items before entering the adjustment main menu.

- Model name (Stylus C40UX/40SX/20UX/20SX)
For the Stylus C40UX, select Model name “Stylus C40UX.”
 - Interface setting (LPT1, LPT2, LPT3, EPUSB1, EPUSB2, EPUSB3)
1. When you run this program, the following menu appears. Select the model name in the screen below.

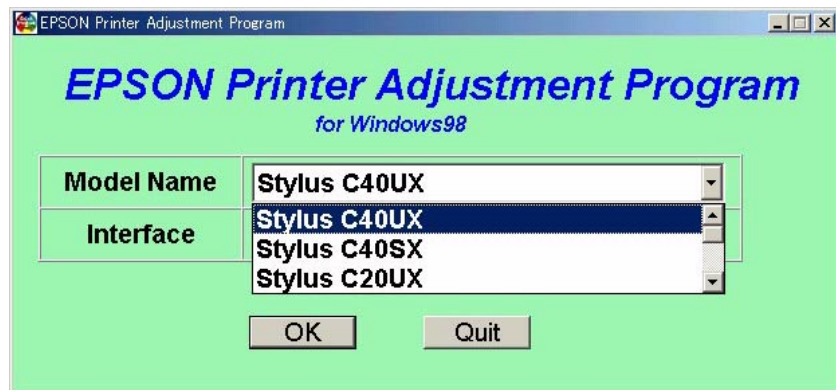


Figure 5-1. Model Name Selection

NOTE: This printer stores model name in the PROM. Therefore, even you select the model name in the screen above, model name will not stored in the EEPROM. Selecting model name in the screen above determines respective special command for each model.

2. Select the Interface port number which you connect the printer to your PC.

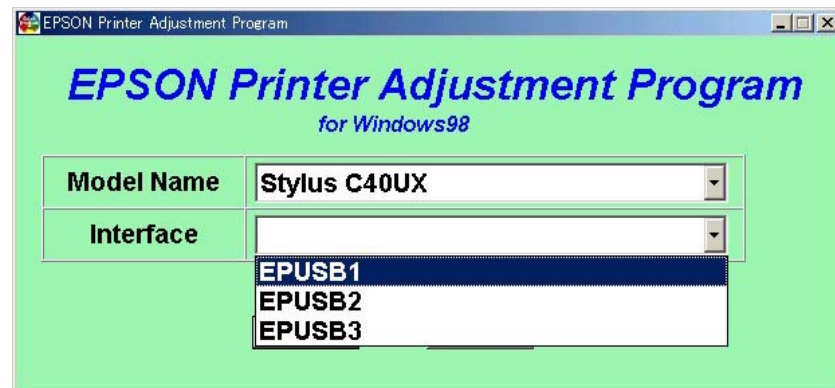


Figure 5-2. Interface Setting

5.1.3 Adjustment Program feature

The adjustment program enables you to set various values correctly to prevent malfunction and fluctuation of printing quality and printing function caused by difference in components and assembly when the printer components are replaced during repair. Basic adjustment items by using this program are shown as follows.

- CHECK
POINT

 - This program does not operate under DOS or Windows 3.X, NT.
 - Perform this adjustment program using parallel I/ F or USB.

Table 5-2. Basic adjustment items

No	Main Menu	Service
1	Adjustment	EEPROM initial setting
		Head ID input
		Bi- D adjustment
		USB ID input
		Top margin
2	Maintenance	Head cleaning
		Initial ink charge
		Refurbishment for DOA
		Protection counter check
		EEPROM check
		EEPROM back up data
3	Print A4 pattern	A4 pattern will print

The user interface of the main menu on this program is shown below.

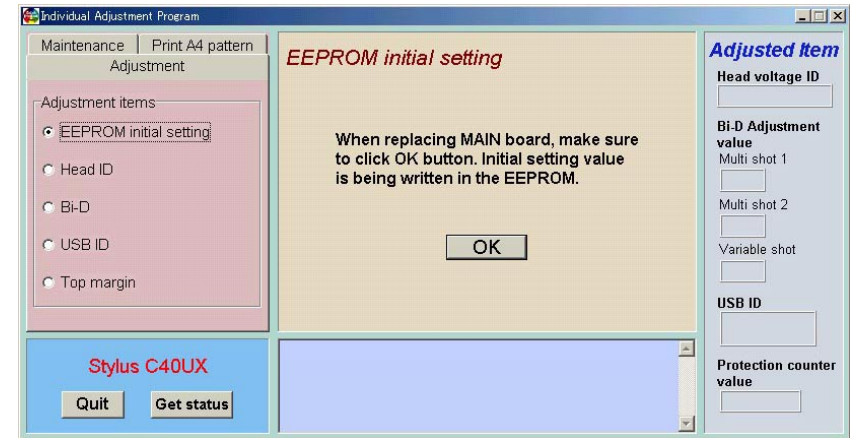


Figure 5-3. Adjustment program main menu

The “Adjusted item” in the right column shows you the adjusted item which executed in this program and it is easy to confirm the adjusted value.

Additionally, this program runs under the D4 (IEEE-1284.4) protocol. So, this program can get the several error statuses even if the printer is error condition, and can control the printer under the error condition. Following explain you the common function of the Adjustment program.

Quit

If you want to exit this program, click the “Quit” button. Following menu is displayed on the screen. And clicking the “Quit” Button in the following menu exit the adjustment program completely. Clicking the “Next” button returns to the Top menu (Initial setting menu) of Figure 5-3.



Figure 5-4. Quit function

Get status

This function is used to get the printer status and following figure is displayed on the screen by clicking the “Get status” button. This function can get the printer status even if the printer is error condition except the main logic circuit failure, and control the printer by using the D4 mode functions.



This program does not display the “Paper out” error status in the Bi-d adjustment even if the paper is out in the ASF. When the paper is out in the ASF, this program continues to send the paper feed command until the paper is set in the ASF.

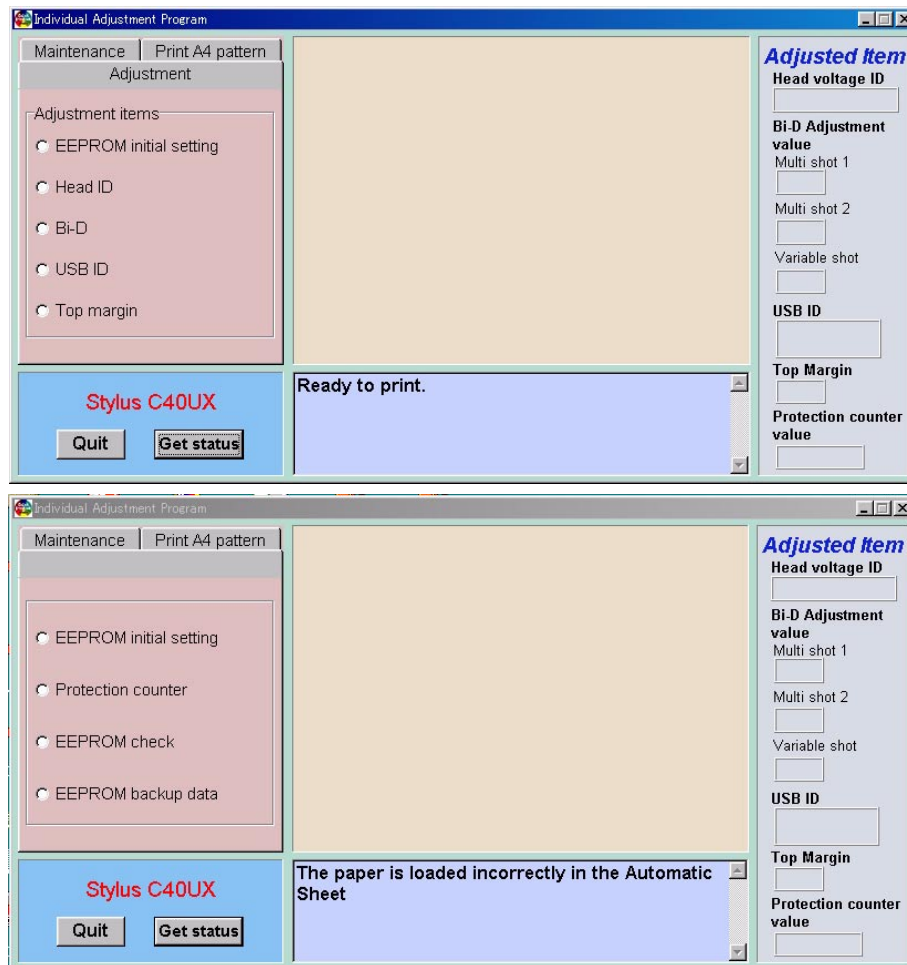


Figure 5-5. Get status function

5.1.4 EEPROM initial setting

This function is used when replacing the MAIN board.

Using this function enables writing of the initial setting values to the new MAIN board's EEPROM.

1. Choose the "EEPROM initial setting" in the Adjustment menu.

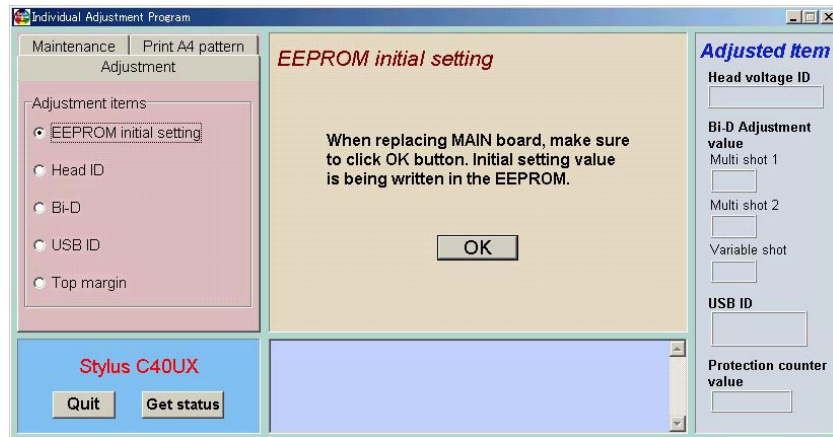


Figure 5-6. EEPROM initial setting

2. Click the "OK" button, then the initial setting values are written to the MAIN board.

5.1.5 Head ID

This adjustment function is required when any of the following parts is replaced.

- Printhead
- Main board
- Printer mechanism

This adjustment function enables you to write printhead Voltage ID into the specific address of the EEPROM. This operation is considered the most important to maintain proper ink discharging system. If any ID is not written correctly, it results in white or color lines and also gives bad influence on dot weight.

1. When replacing any of the parts above, make a note of VH voltage ID in advance. You can find the VH voltage ID on the following position:
 - Printhead: On the top right face of the printhead.
A 6-digit ID code is printed with the QR code on the label.
 - Printer mechanism: On the label of the packing box of the printer mechanism.
2. Run the Adjustment program and enter the Adjustment Main menu.
3. Choose the "Head ID" and click it. The menu shown in the next page appears.

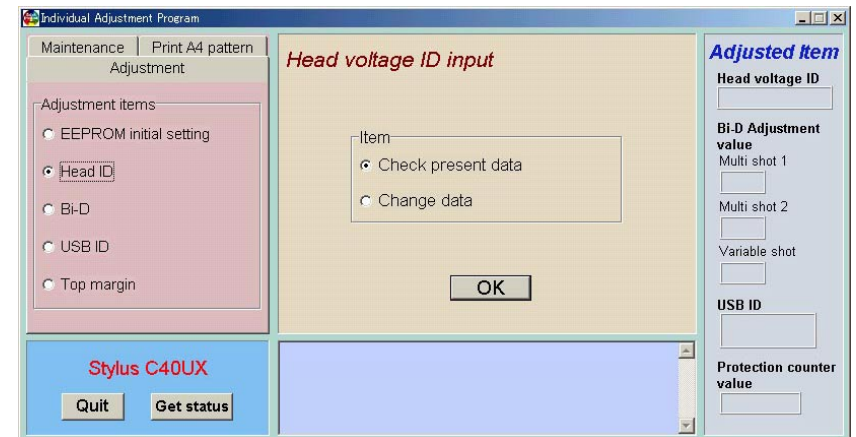


Figure 5-7. Head ID input menu

- Choose the “Check present data” and click the OK button. Following Check present data menu is displayed. Click the OK button, then readout data is displayed.

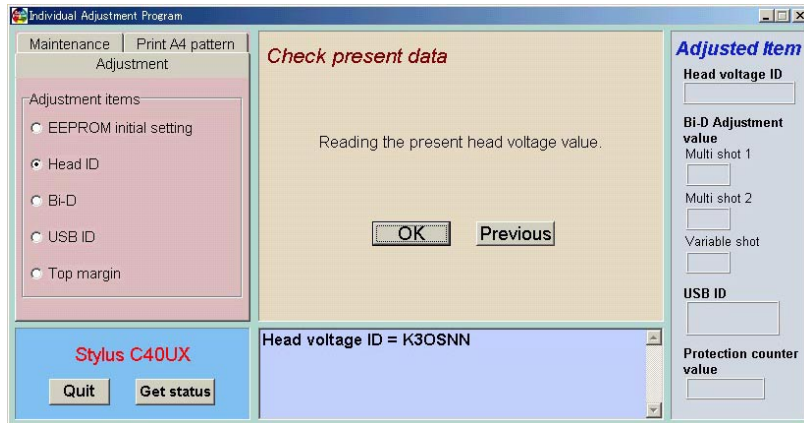


Figure 5-8. Read out the Head ID from the EEPROM

- Choose the “Change data” item in the Head ID input menu and click the OK button. Following Head ID input menu is displayed. Input a 6-digit code of the Head Voltage ID in the following menu.

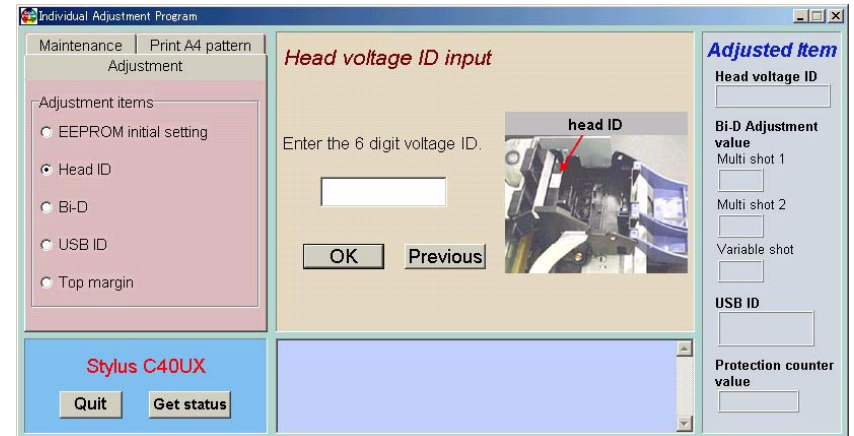


Figure 5-9. Entering the 6-digits Head ID

- When the Head ID is input and writes to the EEPROM, the message is displayed on the bottom column in the menu.

5.1.6 Bi-D

You perform this adjustment to correct differences in printing positions, which is caused by incorrect of printing timing in right and left directions during the Bi-directional printing. Therefore, you are required to perform this adjustment after performing the following operations.

- Replacing the Print mechanism
- Replacing the main board
- Replacing the CR motor
- Replacing the Printhead

1. Choose the “Bi-D” in the “Adjustment menu” as following figure.

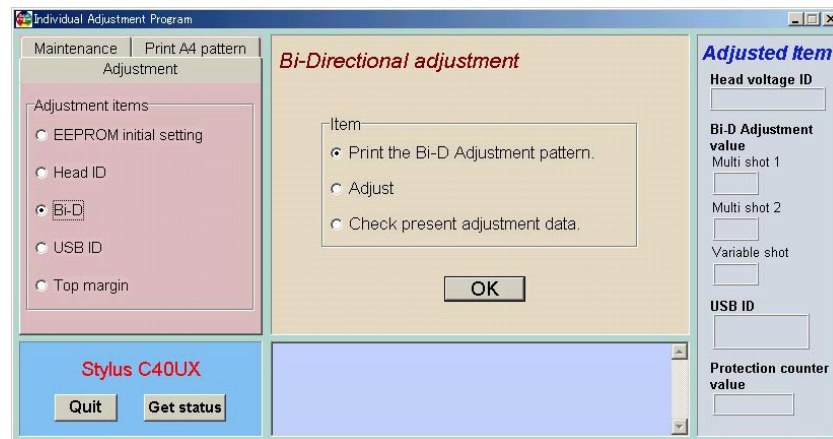


Figure 5-10. Choose the Bi-d adjustment

2. Choose the “Print the Bi-d adjustment pattern” in the “Bi-Directional Adjustment pattern” and click the “OK” button.

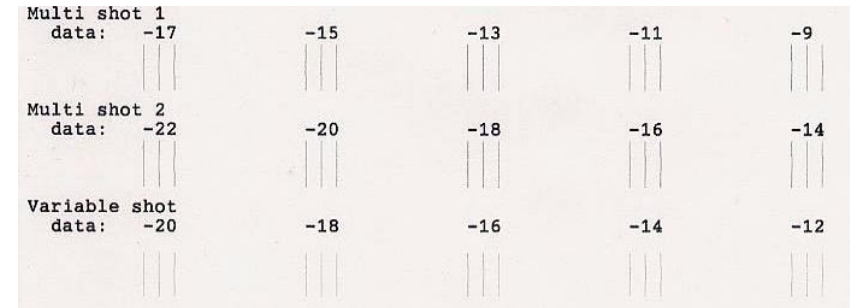


Figure 5-11. Bi-d adjustment pattern

NOTE: As shown in the sample, gaps between passes are sometimes created in different directions among patterns. This unexpected change in direction is caused by an ink jet printer-specific reason, which is an ink jet printer inevitably performs a periodical cleaning specified by the flashing timer even during Bi-D pattern printing, so that the printing direction suddenly changes. However, this directional difference among Bi-D patterns should not be considered, and you can always confirm and adjust the pattern correctly by referring to gap amount only.

3. Click the “Previous” and go back to the “BI-Directional Adjustment” menu. And choose the “Adjust” menu and click the “OK” button.
4. Check the printed pattern and find the misaligned dot type. Choose the misaligned dot size in the following menu and click the “OK” button.

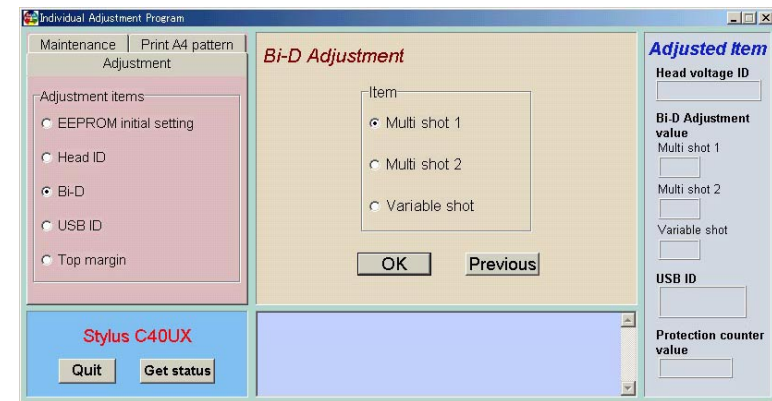


Figure 5-12. Choose the misaligned dot size

5. By choosing the misaligned dot size, following input menu for the adjustment value is displayed. Check the printed pattern again and Input the suitable value in the following menu and click the “OK” button. The input value is written in the specific address of the EEPROM.

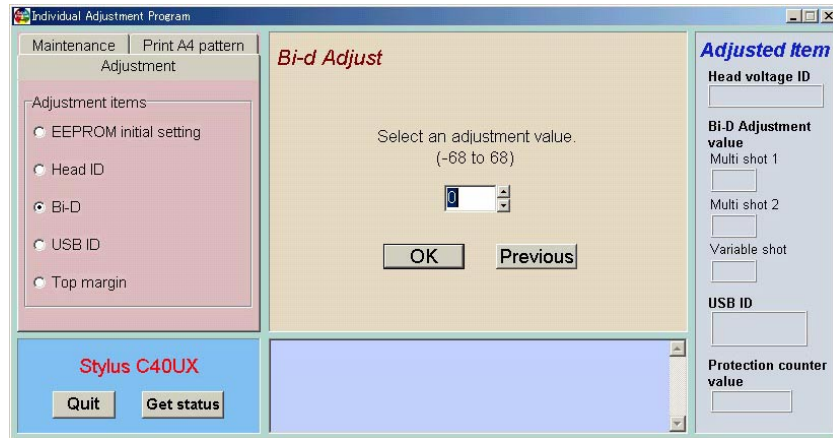


Figure 5-13. Bi-d adjustment input menu

6. To confirm if the adjustment value is suitable, click the “Previous” button and go back to the “Bi-Directional Adjustment” menu. Choose the “Print the Bi-D adjustment patter” and click the “OK” button.

5.1.7 USB ID

When you replace the main board with a new one, you have to input the USB ID newly into the specific address of the EEPROM. When the Printer and the PC are connected with a USB cable, the USB port driver loads the unique code from the specific address of the printer’s EEPROM and the provides the USB port number to the unique code. The USB port driver controls the several USB ports under the Windows 98 environment.

A unique code called USB ID is input to the specific address of the EEPROM in our manufactory and the following total 18-digit code is used as a USB ID for the EPSON ink jet printer.

- Factory line number (3-digit)
- PC number (2-digit)
- Input year/month/date/time (hour, minutes, second) (12-digit)
The timer data of the PC is used for this input data.
- Number 0
A “0” is automatically added for the last digit in the input program.

In repair activity, we use a 10-digit code of the Serial number for a USB ID. The remaining 8digits code is generated in the adjustment program and added to the serial number automatically.

CAUTION

In case the USB ID is not input in the adjustment program after the main board is replaced to new one, the USB ID may not possibly unique one. In this case, the USB ID conflicts another peripheral USB ID in the USB port driver and the another USB peripheral may not possibly be used with the USB.

1. Choose the “USB ID input” in the Adjustment menu.

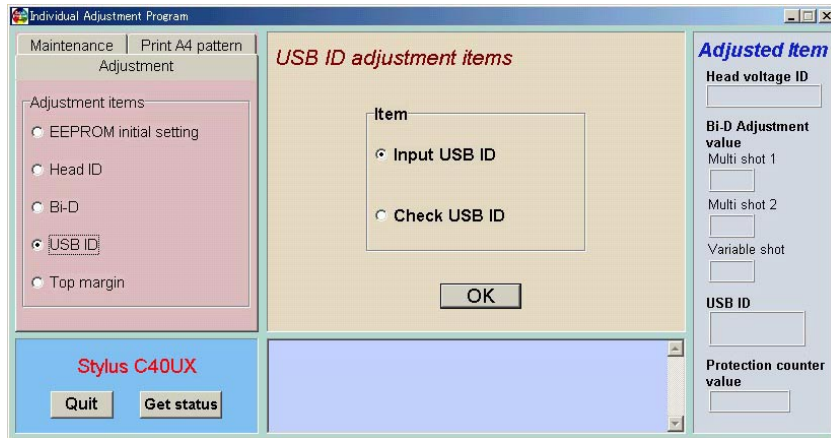


Figure 5-14. Choose the USB ID input menu

2. Choose the “Input USB ID” and click “OK” button in the “USB ID check/Input” menu. Following menu is displayed.

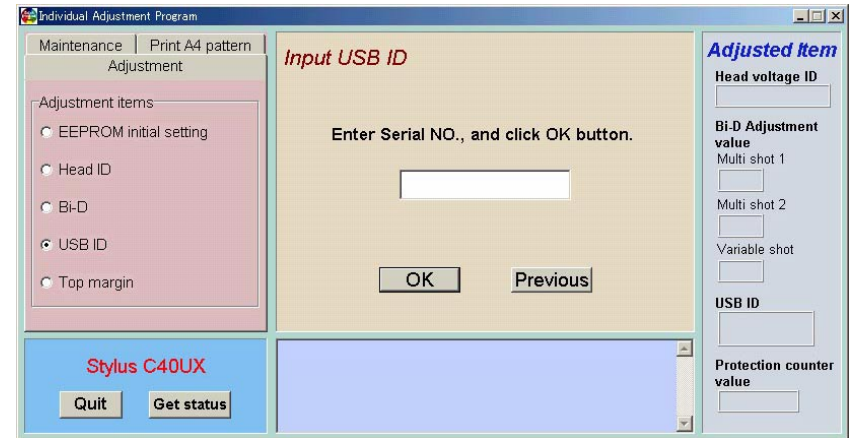


Figure 5-15. Choose the USB ID input menu

3. Check the 10digits code of the serial number on the serial number label stuck around the rear side of the Upper housing. Input the 10digits code of the serial number in the input menu and click “OK” button.

NOTE: Even though you input irresponsible another 10digits code and click the “OK” button, the program allow to input the code and write down it the specific address of the EEPROM. But, there is a possibility that the code is not unique and the code conflicts another USB ID in the USB port driver.

5.1.8 Top margin

This function can be used to change the top margin value.

You are required to perform this adjustment after performing the following operations.

- Replacing the Print mechanism
- Replacing the main board

1. Choose the “Top margin” in the Adjustment menu.

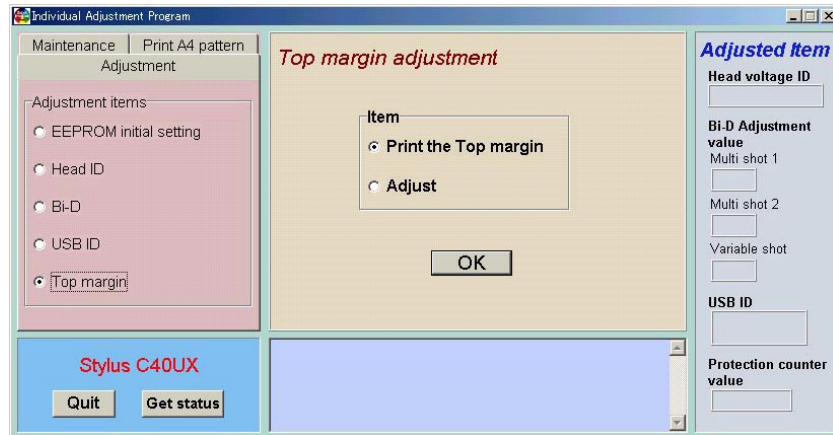


Figure 5-16. Choose the Top margin menu

2. Choose the “Print the Top margin” in the “Top margin adjustment” and click the “OK” button.

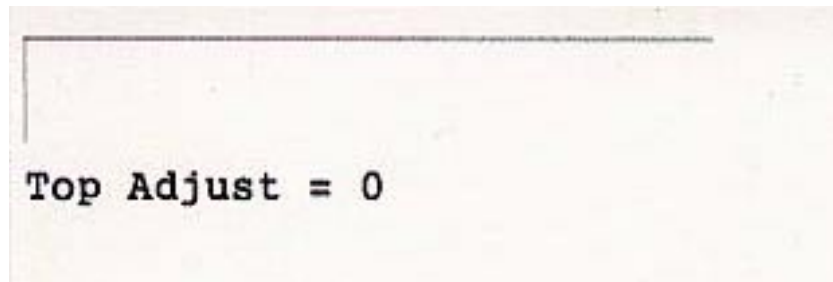


Figure 5-17. Top margin adjustment pattern



Make sure that Top margin is 3mm by measuring with scale.

3. Check the printed pattern. The printed pattern will show a line indicating the current top margin and will show the setting value.
4. When adjusting the top margin, select “Adjust” from “Top margin adjustment,” then click the “OK” button.
5. Input an adjustment value that is within the range $-127 \sim 127$, then click the “OK” button. The adjustment value is stored in the EEPROM.

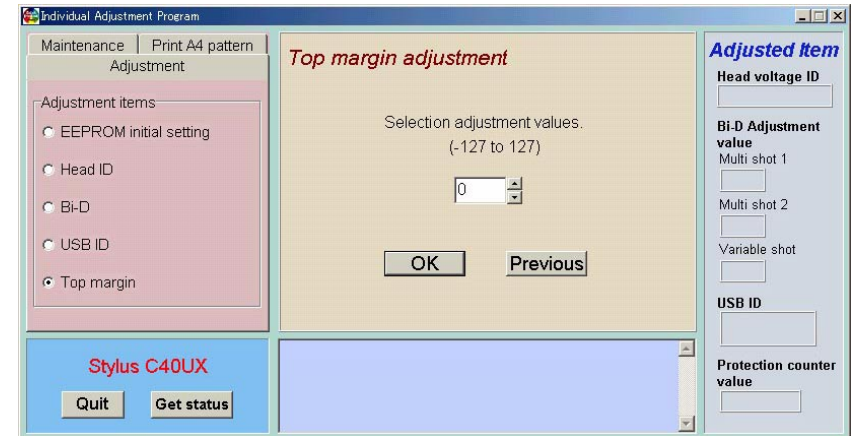


Figure 5-18. Top margin adjustment input menu

6. When checking the adjusted top margin, return to the previous screen by pressing the “Previous” button, then select “Print the Top Margin” and click the “OK” button.

5.1.9 Head cleaning

This printhead cleaning is CL1' and about 1/8 of the brand-new black I/C and 1/17 of the brand-new color I/C are consumed. Before use this function, check the remaining ink amount of the both I/C by using the "Get status" function.

1. Choose the "Head cleaning" in the Maintenance menu.

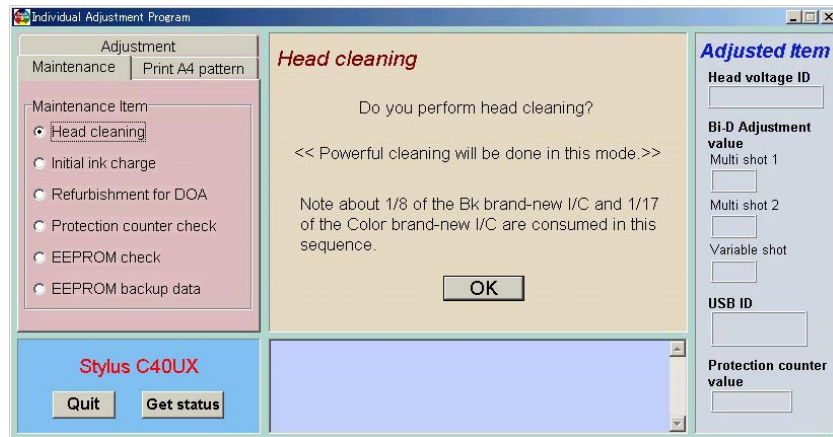


Figure 5-19. Choose the Head cleaning menu

2. Click the "OK" button in the menu. The powerful cleaning is performed.

5.1.10 Initial ink charge

After you replaced any of the following units, perform initial ink charge and return the printer after making sure that ink is ejected correctly from the printhead.

- After replacing the printer mechanism
- After replacing or removing the printhead



Before you perform the initial ink charge operation, replace the installed cartridges with new ones, because the ink amount used for the initial ink charge operation is so large.

1. Choose the "Initial ink charge" in the Maintenance menu.

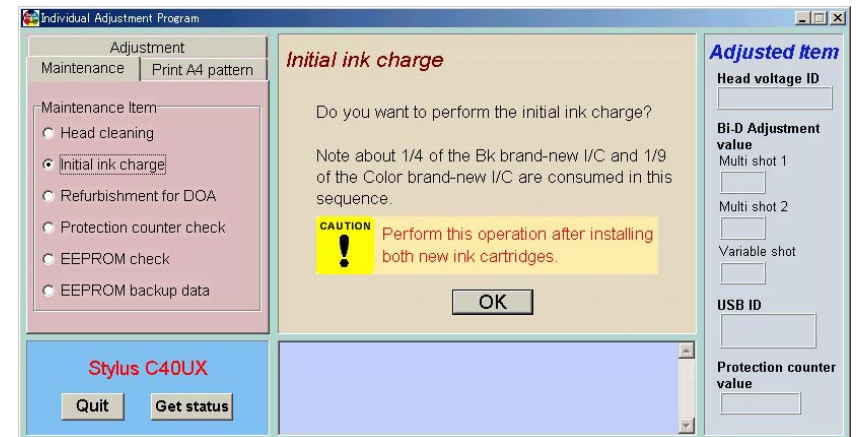


Figure 5-20. Choose the Initial Ink Charge menu

2. Click the "OK" button in the menu. The initial ink charge is performed.

NOTE: As described in the menu message, about 1/4 amount of the Black ink cartridge and 1/9 amount of the Color ink cartridge are consumed in the initial ink charge operation.

5.1.11 Refurbishment for DOA

If you clean the cavity of the printhead and cap assembly, this function will be useful.

CAUTION



- After carry out this function, replace the waste drain ink pad with new one and reset the Waste drain ink pad counter. Otherwise, the ink or S46 liquid may leak from the pad during the transportation.
- Prepare the following tool.
*Dummy ink cartridge, Injector, S46 liquid
- Do not carry out this program repeatedly. This operation is available only one time. Excessive operation causes overflow of the ink and S46 liquid.
- When you refurbish the repair product by using this program, do it on your responsibility.
- When you charge S46 liquid into the dummy ink cartridge with the Injector, make sure fill out the dummy ink cartridge with S46 liquid. In case enough S46 liquid is not charged into the dummy cartridge, the printhead will not cleaned and not filled with the S46 liquid enough in this operation.
- Keep the S46 liquid and the dummy ink cartridge clean.

1. Choose the “Refurbishment for DOA” in the Maintenance menu.

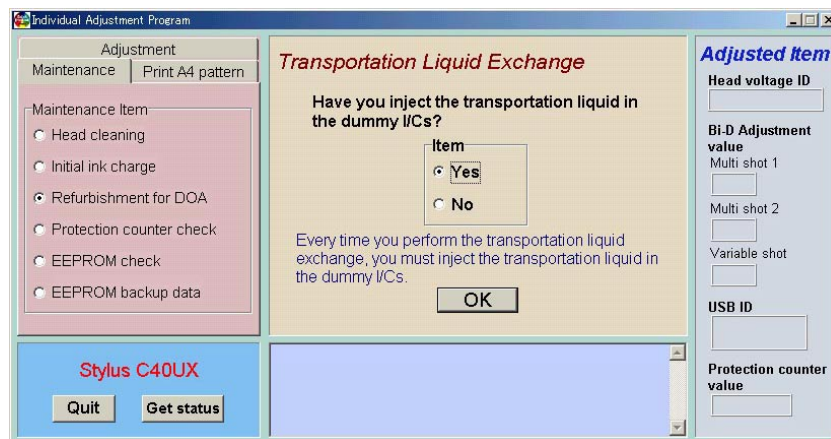


Figure 5-21. Choose the Refurbishment for DOA menu

2. Set the dummy cartridge in the printer using the ink replacement function.
3. Select “Yes” under “Item,” then click the “OK” button. The “Refurbishment for DOA” function is then executed.

5.1.12 Protection counter check

The program allows you to check or clear the current protection counter value (waste ink amount counter).

Check the present counter value

1. Choose the “Check the present counter values” in the “Maintenance” menu and click the “OK” button.

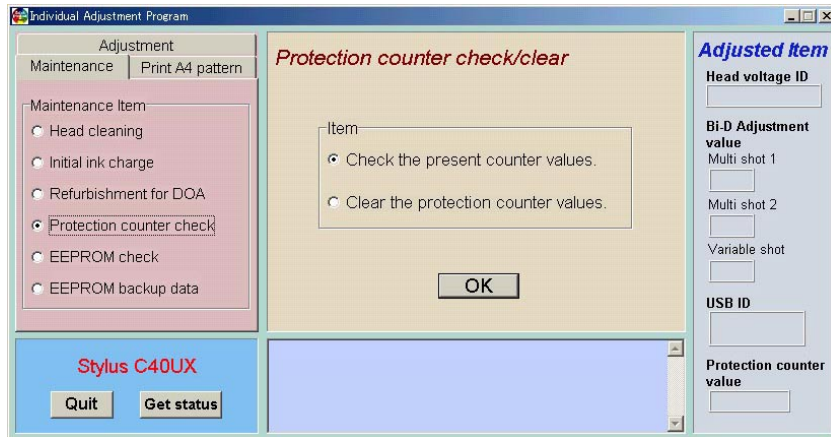


Figure 5-22. Choose the Check the present counter value

2. After read the Caution description on the above menu, click the “OK” button in the menu. The present counter value is displayed on the bottom column as following figure.

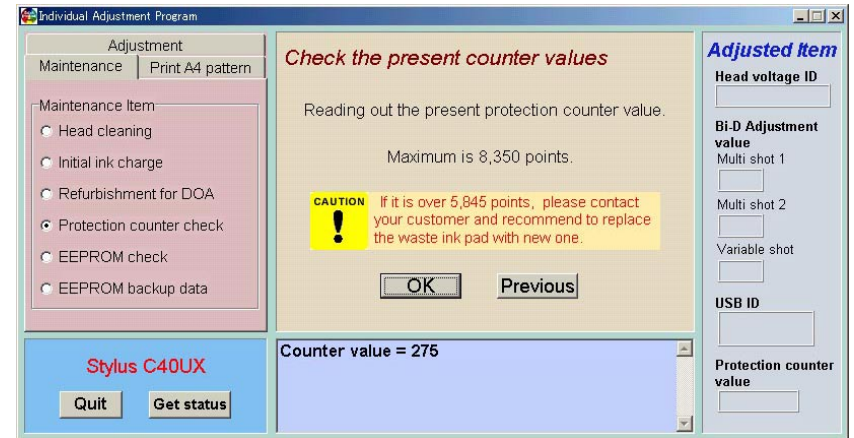


Figure 5-23. Present counter value

3. If the present counter value is over 5845 points, we recommend you to replace the Waste ink drain pad to new one.

Clear the present counter value

1. Choose the “Clear the present counter values” in the “Maintenance” menu and click the “OK” button.

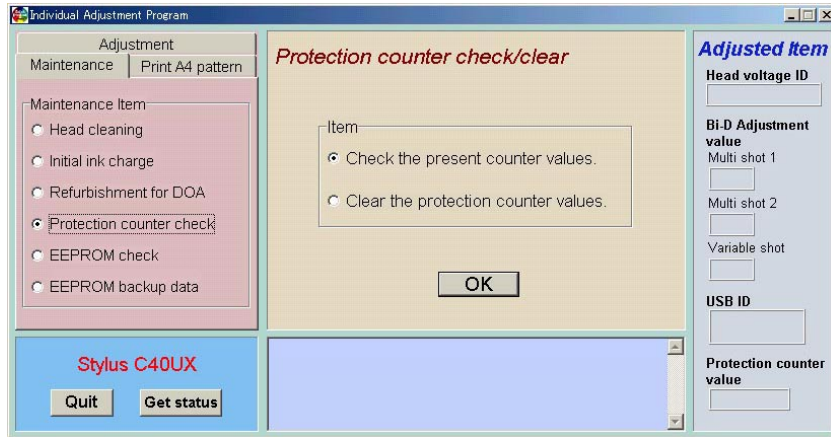


Figure 5-24. Choose the Clear the present counter value

2. After you read the description on the menu, click the “OK” button.

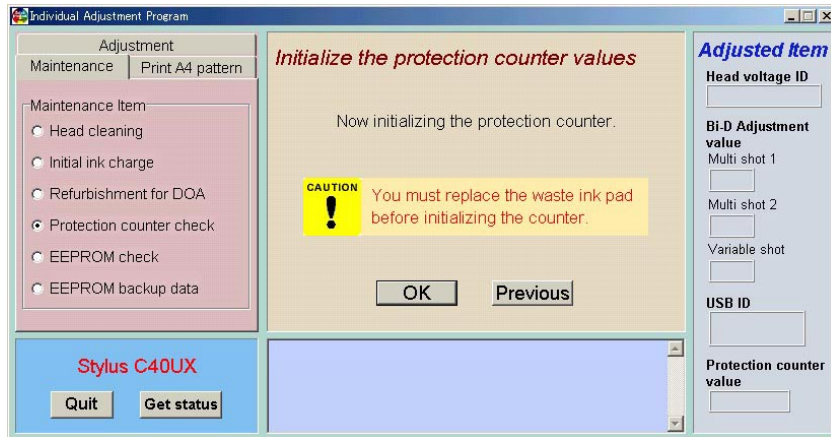


Figure 5-25. Clear the present counter value



Be sure to replace the installed waste ink pad with a new one after or before you clear the current protection counter value.



The initial value of the Protection counter is differ by destination as bellow:

- ESP : 0
- Excepting ESP: 2940

5.1.13 EEPROM check

You can check the EEPROM data or can write the specific data into the specific address of the EEPROM directly even if the printer is error condition. (In case one of the main logic circuit such as CPU, I/F receiver IC, RAM, EEPROM is broken, this function is not available) Select the “EEPROM check” function in the Maintenance menu.

The main menu of this function is as following figure. The following two functions are built in this program.

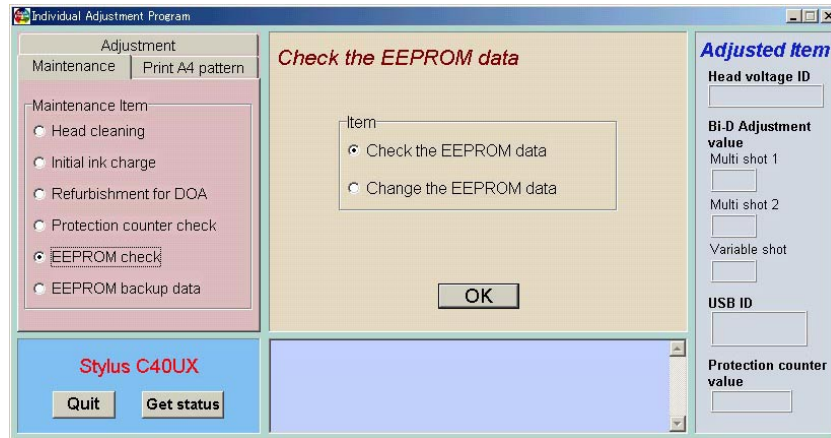


Figure 5-26. EEPROM check function

- Check the EEPROM data**
 You can check the specific data stored in the specific address of the EEPROM.
 Input the specific address with hexadecimal code. Use this function in your analysis usefully.

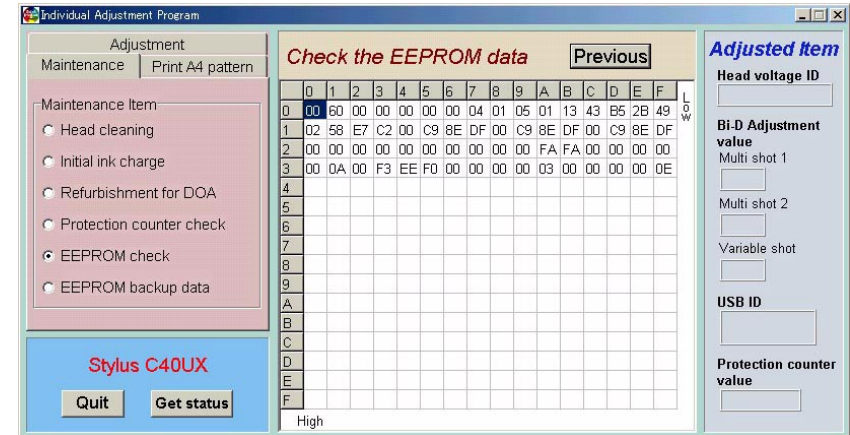


Figure 5-27. Check the EEPROM data

- Change EEPROM data**
 You can change the specific data stored in the specific address of the EEPROM.
 However, do not use this function except the special case. Careless usage causes any trouble.

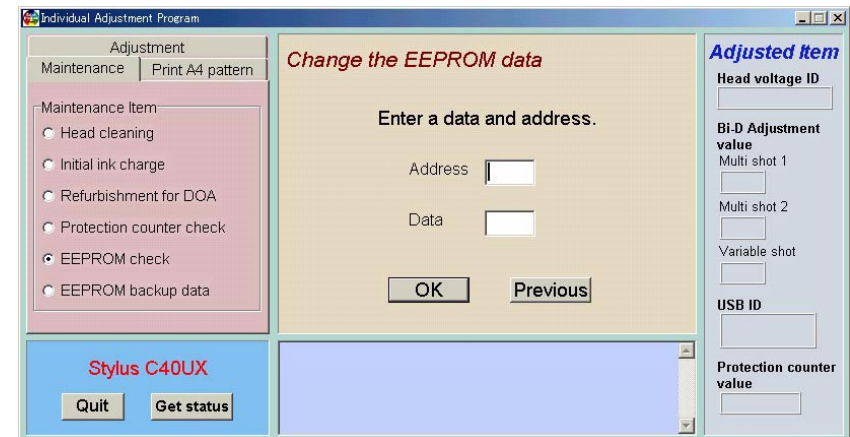


Figure 5-28. Change the EEPROM data

5.1.14 EEPROM back up data

This function is used when replacing the MAIN board.

Using this function, the data on the currently used MAIN board are backed up, then the backed up data can be written to the EEPROM on the new MAIN board after replacement.



This function may fail. If it fails, replace the MAIN board with a new one, then carry out the specified adjustments in order.

1. Choose the “EEPROM backup data” in the Maintenance menu.

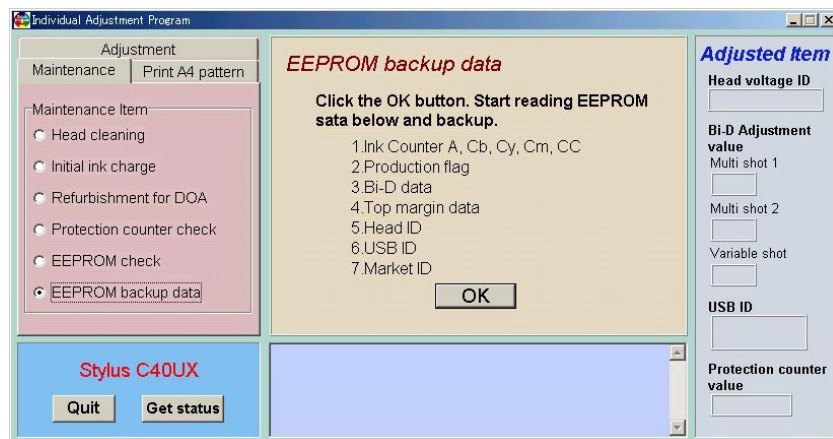


Figure 5-29. EEPROM backup data

2. The EEPROM data on the current MAIN board are backed up by clicking the “OK” button. The following message is displayed when the data backup operation is completed. Replace the printer’s MAIN board, then turn the power ON again and click the “OK” button.



Figure 5-30. Replace the defective main board with new one

3. The backed up data will be written to the EEPROM on the new MAIN board.

5.1.15 A4 pattern will print

We recommend to use this function to check the repaired product quality in your final stage of your repair. The following 6 items are printed on the check pattern.

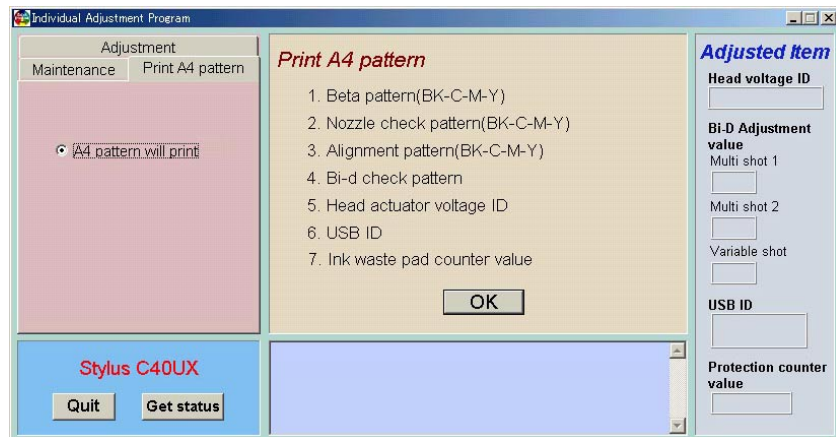


Figure 5-31. A4 Check pattern



- The check point for the first black and each color solid pattern (beta pattern 360 x 360dpi normal dot) in the A4 Check pattern is as follows.
 - Any white line is not observed.
 - Uneven banding is not observed extremely.
- The check point for the second Nozzle check pattern (120dpi) is as follows.
 - Ink is fired from all nozzles.
 - Uneven banding is not observed extremely.
- The check point for the third Alignment pattern is as follows.
 - Each vertical line is printed straight.
- If any incorrect printing is observed on the A4 Check pattern, perform the head cleaning or bi-d adjustment. If the phenomenon is not improved, replace the printhead or suitable mechanical parts.

CAUTION



Do not print the A4 Check pattern on the EPSON exclusive paper such as Photo quality ink jet paper. This check pattern is for the plain paper. So, use the Plain paper for this check pattern printing.

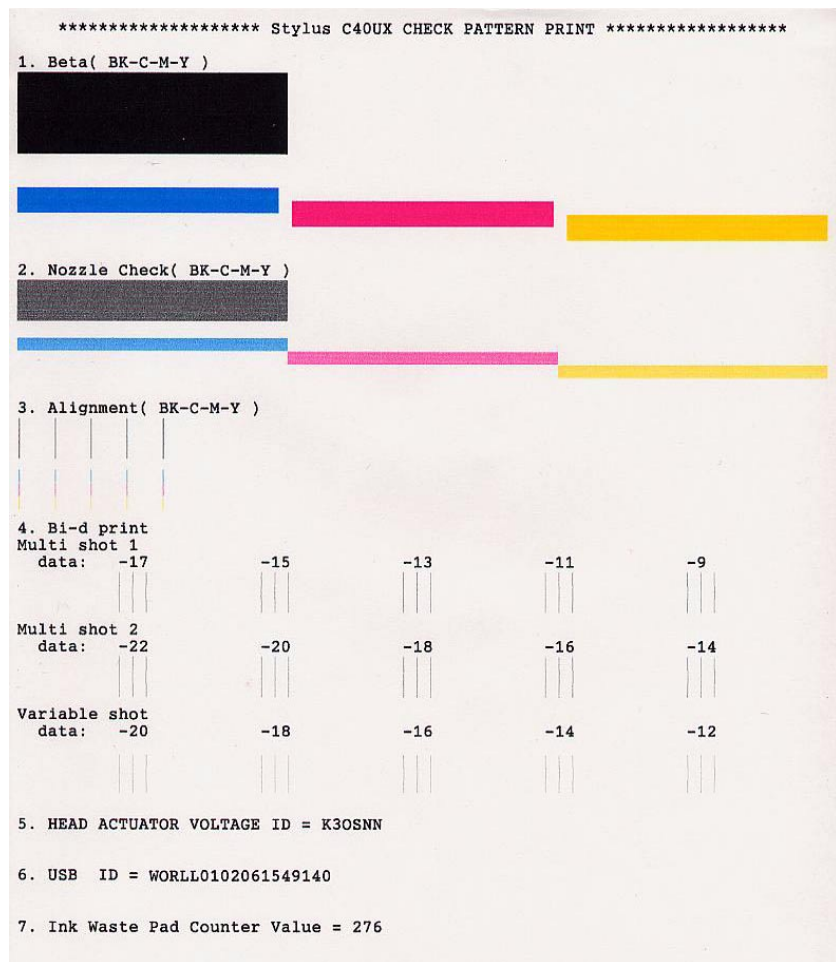


Figure 5-32. A4 Check pattern

CHAPTER

6

MAINTENANCE

6.1 Overview

This section provides information to maintain the printer in its optimum condition.

6.1.1 Cleaning

This printer has no mechanical components which require regular cleaning except the printhead. Therefore, when returning the printer to the user, check the following parts and perform appropriate cleaning if stain is noticeable.



- **Never use chemical solvents, such as thinner, benzine, and acetone to clean the exterior parts of printer like the housing. These chemicals may deform or deteriorate the components of the printer.**
- **Be careful not to damage any components when you clean inside the printer.**
- **Do not scratch the surface (coated part) of PF roller assembly. Use soft brush to wipe off any dusts. Use a soft cloth moistened with alcohol to remove the ink stain.**
- **Do not use cleaning sheet included in the media for normal usage. It may damage the coated surface of PF roller. If the adhesive surface of the cleaning sheet is set to the ASF LD roller side and used to clean the ASF LD roller surface, it is no problem.**

- Exterior parts
Use a clean soft cloth moistened with water and wipe off any dirt. If the exterior parts are stained with ink, use a cloth moistened with neutral detergent to wipe it off.
- Inside the printer
Use a vacuum cleaner to remove any paper dust.
- ASF LD Roller
If paper dust on the surface of ASF LD Roller lowers the friction, set the adhesive surface of the cleaning sheet included in the media to the surface of the ASF roller and repeat loading paper from the ASF.

6.1.2 Service Maintenance

If print irregularity (missing dot, white line, etc.) has occurred or the printer indicates “Maintenance Error”, take the following actions to clear the error.

□ Head Cleaning:

The printer has a built-in head cleaning function, which is activated by operating the control panel.

Confirm that the printer is in stand-by state (the POWER indicator is not blinking), and hold down the Error Reset SW on the control panel for more than 3 seconds.

The printer starts the cleaning sequence (The POWER indicator blinks during the cleaning sequence).

□ Maintenance Error Clear:

Ink is used for the operations such as cleaning as well as printing. Therefore, the printer wastes certain amount of ink and drains it into waste ink pad, while counting the amount of the waste ink. Once the amount of the waste ink reaches the predetermined limit, the printer indicates “Maintenance Error” and the waste ink pad should be replaced.

- **Overflow Counter Limit:**
Overflow Counter (Protection Counter A) ≥ 8350
- **Timing for Replacing the Waste Ink Pad:**
When the total amount of the waste ink reaches the predetermined limit, the LED indicates “Maintenance Error”.
Also, during repair servicing, check the ink counter along with the firmware version, ink counter, select code page, nozzle check pattern on the status printing sheet. If the ink counter value is close to its limit, notify your customer and recommend that the waste ink pad be replaced (If the waste ink pad is not replaced at that time, there is a possibility that “Maintenance Error” will occur soon after the printer is returned to the customer). Once you have the confirmation of the customer, replace the waste ink pad.
- **Replacement Procedure:** Refer to 4.2.3 Waste ink pad removal
- **After the Replacement:**
Reset the Overflow Counter (Protection Counter A) : Refer to 5.1.12
Protection counter check

6.1.3 Lubrication

The characteristics of the grease have great affects on the mechanical function and durability, especially does the characteristics about temperature environment. The type and amount of grease used to lubricate the printer parts are determined based on the results of internal evaluations. Therefore, be sure to apply the specified type and amount of grease to the specified part of the printer mechanism during servicing.



- **Never use oil or grease other than those specified in this manual. Use of different types of oil or grease may damage the component or give bad influence on the printer function.**
- **Never apply larger amount of grease than specified in this manual.**

Table 6-1. Specified Lubricants

Type	Name	EPSON Code	Supplier
Grease	G-46	1039172	EPSON
Grease	G-58	T.B.D	EPSON

Table 6-2. Lubrication Type/Point

No.	Lubrication Type/Point	Remarks
1	<p><Lubrication Point></p> <ul style="list-style-type: none"> Specified area on the Main frame. Refer to Figure 6-1, "Lubrication point 1". <p><Lubrication Type></p> <ul style="list-style-type: none"> G-58 <p><Lubrication Amount></p> <ul style="list-style-type: none"> 100mg x 4 points 	<ul style="list-style-type: none"> Use a brush to apply it. After lubrication, move the CR unit left or right and smooth out the grease on the Front frame.
2	<p><Lubrication Point></p> <ul style="list-style-type: none"> Specified area on the Front frame. Refer to Figure 6-2, "Lubrication point 2". <p><Lubrication Type></p> <ul style="list-style-type: none"> G-58 <p><Lubrication Amount></p> <ul style="list-style-type: none"> Φ1mm x 200mm 	<ul style="list-style-type: none"> Use a syringe to apply it. After lubrication, move the CR unit left or right and smooth out the grease on the Front frame.
3	<p><Lubrication Point></p> <ul style="list-style-type: none"> Specified area on the Paper eject roller. Refer to Figure 6-3, "Lubrication point 3". <p><Lubrication Type></p> <ul style="list-style-type: none"> G-46 <p><Lubrication Amount></p> <ul style="list-style-type: none"> Φ1mm x 1mm x 9points 	<ul style="list-style-type: none"> Use a syringe to apply it. After lubrication, turn the Paper eject roller and smooth out the grease on the Paper eject roller.

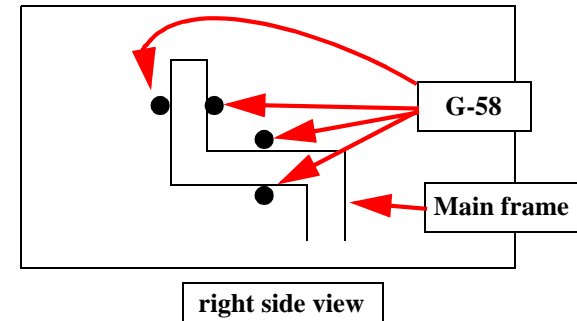
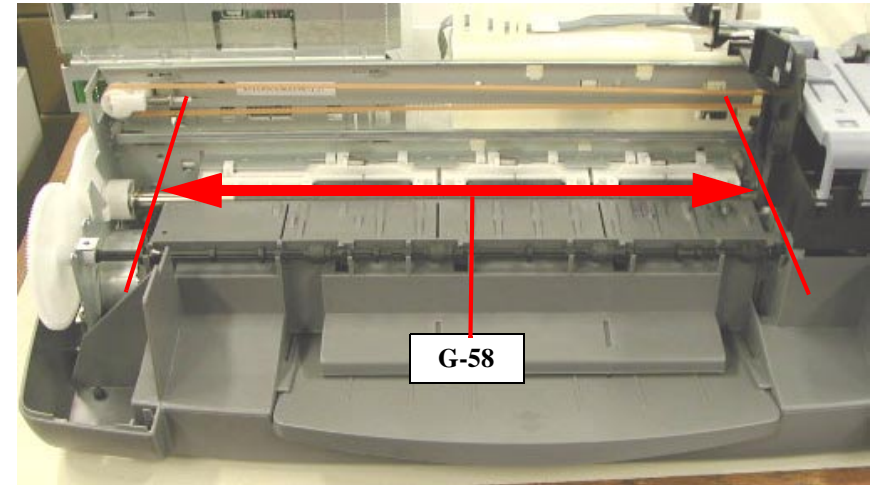


Figure 6-1. Lubrication point 1

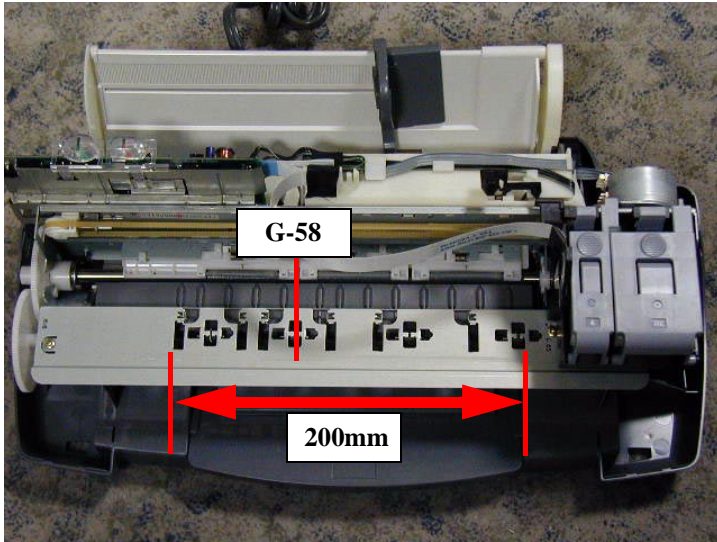


Figure 6-2. Lubrication point 2

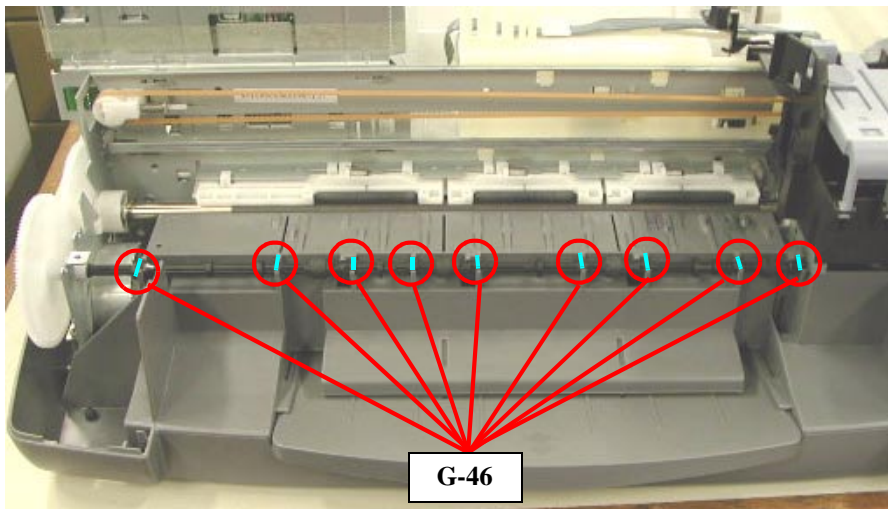


Figure 6-3. Lubrication point 3

CHAPTER 19

7

APPENDIX

7.1 Connector Summary

7.1.1 Major Component Unit

The Major component units of this printer are as follows.

- Main Board (C413MAIN or C413MAIN-B)
- Power Supply Board (C417/PSE)

The figure below shows how these components connect.

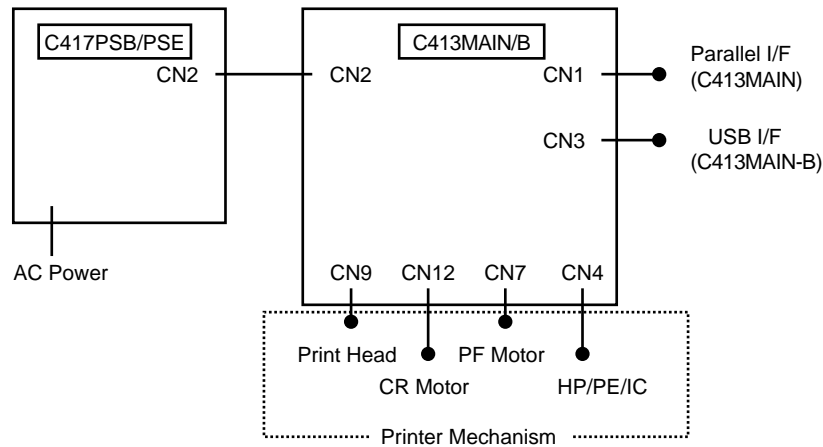


Figure 7-1. Connection of the Major Components

See the following tables for the connector summary for the C413MAIN/B board and each connector's pin alignment.

Table 7-1. Connector Summary for C413MAIN/B

Connector	Function	Table to refer to
CN4	For connection with the HP/PE/IC/sensor	Table 7-2
CN12	For connection with the CR motor	Table 7-3
CN7	For connection with the PF motor	Table 7-4

Table 7-1. Connector Summary for C413MAIN/B

Connector	Function	Table to refer to
CN9	For connection with the Print Head	Table 7-5
CN2	For connection with the Power supply board	Table 7-6
CN1	For connection with the parallel interface	Refer to "IEEE-1284 Parallel Interface (Forward Channel)"
CN3	For connection with the USB interface	Refer to "1.3.1 USB INterface"

Table 7-2. CN4-HP/PE/IC Sensor

Pin	Signal Name	I/O	Function
1	SIG	In	Sensor detect signal
2	GND	---	Ground
3	VCC	---	Sensor Power Supply

Table 7-3. CN12-CR Monitor

Pin	Signal Name	I/O	Function
1	CRA	Out	Phase drive signal (A)
2	CRB	Out	Phase drive signal (B)
3	CR-A	Out	Phase drive signal (-A)
4	CR-B	Out	Phase drive signal (-B)

Table 7-4. CN3-PF Motor

Pin	Signal Name	I/O	Function
1	PFA	Out	Phase drive signal (A)
2	PFB	Out	Phase drive signal (B)
3	PF-A	Out	Phase drive signal (-A)
4	PF-B	Out	Phase drive signal (-B)

Table 7-5. CN9-Printhead

Pin	Signal Name	I/O	Function
1	THM	In	Thermistor detect signal
2	CH	Out	Waveform selection signal for MS shot & variable shot
3	GND	---	Ground
4	LAT	Out	Head data latch pulse output
5	GND	---	Ground
6	NCHG	Out	All nozzle fire selection pulse
7	GND	---	Ground
8	SCK	Out	Serial clock
9	GND	---	Ground
10	SI2	Out	Print data output (2)
11	SP	Out	Select signal for CH signal
12	SI1	Out	Print data output (1)
13	VDD	---	Logic power supply (+5V)
14	GND9	---	Ground
15	COM	---	Head drive pulse (trapezoid waveform)
16	VHV	---	+42V power supply for nozzle selector

Table 7-6. CN2-Power Supply Board

Pin	Signal Name	I/O	Function
1	PSC	Out	Power supply switch output signal
2	GND	---	Ground
3	+42V	---	Mechanism driven power supply
4	GND	---	Ground
5	+5V	---	Logic power supply

7.2 EEPROM Address Map

Table 7-7. EEPROM Address Map

Address	Explanation	Setting	QPIT setting	Factory setting
00H	Ink flag 1	Bit7: CSIC Disable Bit6: black one-time Bit5: color one-time Bit4: Initial charge required Bit3: Reserved Bit2: ink cleaning seq. Bit1: black CL required Bit0: color CL required	00H	10H
01H	Ink flag 2	Bit7: Printed after Cleaning 0:Not printed after Cleaning 1:Printed after Cleaning Bit6: Black 1 st Ink Cartridge Bit5: Color 1 st Ink Cartridge Bit4: Bk CSIC changed Flag1 Bit3: YMC CSIC changed Flag1 Bit2: YMC cartridge change and cleaned 0:first cartridge 1:changed Bit1: Black cartridge change and cleaned 0:first cartridge 1:changed Bit0: Black cartridge change and cleaned 0:with YMC cartridge 1:alone	00H	00H
02H	CL time		00H	00H
03H			00H	00H

Table 7-7. EEPROM Address Map

Address	Explanation	Setting	QPIT setting	Factory setting
04H	CPU Time		00H	00H
05H			00H	00H
06H	accumulated printing time		00H	00H
07H			00H	00H
08H	Intial Charge Counter		00H	00H
09H	04mode I/F	Bit7:I/F Control Flag Bit6: Bit5:Reserved Bit4: Bit3:D4mode USB Bit2: Bit1:D4mode Parallel Bit0:	04H	04H ^a
0AH	Ink counter A0		00H	(*1) ^e
0BH			00H	(*1) ^e
0CH	Ink counter Rb0		00H	00H
0DH			00H	00H
0EH	Ink counter Ry0		00H	00H
0FH			00H	00H
10H			00H	00H
13H			00H	00H
14H	Ink counter Cy		00H	00H
17H			00H	00H

Table 7-7. EEPROM Address Map

Address	Explanation	Setting	QPIT setting	Factory setting
18H 1BH	Ink counter Cm		00H 00H	00H 00H
1CH 1FH	Ink counter Cc		00H 00H	00H 00H

data in 00h - 1Fh are written to EEPROM at NMI

Address	Explanation	Setting	QPIT setting	Factory setting
20H 23H	Ink counter Clm		000H 000H	000H 000H
24H 27H	Ink counter Clc		00H 00H	00H 00H
28H	ERROR Code		00H	00H
29H	Production flag	Bit7:dummy flag Bit6:Reserved Bit5: Bit4: Bit3: Bit2: Bit1: Bit0:Change of the model*c 1:for Model-1 0:for Model-2	01H	01H (*1)
2AH	Bi-D Adjustment 4 for ND BK shift Value	-72<=n<=+72 Units 1/1440inchWorkaround;Bi	00H	(*1)

Address	Explanation	Setting	QPIT setting	Factory setting
2BH	Bi-D Adjustment for ND Cl shift Value	-72<=n<=+72 Units 1/1440inchWorkaround;Bi	00H	(*1)
2CH	Reserved		00H	00H
2DH	Manufacturer setting	Bit7: Name mode Bit6: Bit5: Customer name Bit0:	00H	(*1)*d
2EH	Reserved		00H	00H
2FH	Reserved		00H	00H
30H	Interface selectionow	Bit7, 6, 5, 4: Reserved Bit3: USB Bit2: Reserved Bit1: Parallel Bit0: Auto	00H	00H
31H	Interface time-outParall	0 to 255 (by second, value of 0 means 10seconds).	00H	00H
32H	I/F SpeeddIn	Bit7: Reserved Bit6: Bit5: Reserved Bit4: Bit3: ECP speed Bit2: Bit1: Compatibility speed Bit0:	00H	00H
33H	Bi-D Adjustment 1 (for Multishot1)ility speed	-72<=n<=+72(by 1/2880inch)	00H	(*1)
34H	Bi-D Adjustment 2 (for Multishot2)	-72<=n<=+72(by 1/2880inch)	00H	(*1)

Address	Explanation	Setting	QPIT setting	Factory setting
35H	Bi-D Adjustment 3 (for Variable shot)	-72<=n<=+72(by 1/2880inch)	00H	(*1)
36H	Reserved		00H	00H
37H	Reserved		00H	00H
38H	Reserved		00H	00H
39H	1stDot Position Adjustment	-72<=n<=+72 (by 1/2880inch)	00H	(*1)
3AH	CL2 Counter KKd-7		00H	03H
3BH	Total Timer CL Counter		00H	00H
3CH	Printer For CSIC		00H	89H:World 09H:Japan
3DH 3EH	CSIC1_InkName1; CSIC2_InkName1;		00H	00H
3FH	Head Actuator Rank ID for VhN	+1<=n<=+32	00H	(*1)
40H	Head Actuator Rank ID for VhM	+1<=n<=+37	00H	(*1)
41H	Head Actuator Rank ID for VhL	+1<=n<=+34	00H	(*1)
42H	Head Actuator Rank ID for VhV	+1<=n<=+34	00H	(*1)
43H	Head Actuator Rank ID for VhU	+1<=n<=+40	00H	(*1)
44H	Head Actuator Rank ID for VhM2	+1<=n<=+34	00H	(*1)
45H	Head Actuator Rank ID for VhB	+1<=n<=+34	00H	(*1)
46H	Head Actuator Rank ID for AR	0<=n<=+6	00H	(*1)

Address	Explanation	Setting	QPIT setting	Factory setting
47H	Head Actuator Rank ID for IwB	+30<=n<=+70	00H	(*1)
48H	Head Actuator Rank ID for IwC	+30<=n<=+70	00H	(*1)
49H	Head Actuator Rank ID for IwM	+30<=n<=+70	00H	(*1)
4AH	Head Actuator Rank ID for IwY	+30<=n<=+70	00H	(*1)
4BH	Head Actuator Rank ID for IwLC	+30<=n<=+70	00H	(*1)
4CH	Head Actuator Rank ID for IwLM	+30<=n<=+70	00H	(*1)
4DH-5EH	USB IdHe		00H	(*1)
5FH	Market ID	Stylus C40 :00Hor 01H Stylus C20 :02Hor 03H Custom :04H	00H	Same as the settings
60H-7DH	Model NamedHe		00H	-
7EH	PassworddHe		55H	-
7FH	PassworddHe		33H	-

*1 : Adjusted at factory

*a : D4mode setting (EEPROM 09H)

USB

Bit3	Bit2	D4mode
0	0	Auto
0	1	On
1	0	Off

Parallel

Bit1	Bit0	D4mode
0	0	Auto
0	1	On
1	0	Off

*c: Model 1 and model 2 show the following product.
 Model-1: EPSON Stylus C20SX , EPSON Stylus C20UX
 Model-2: EPSON Stylus C40SX , EPSON Stylus C40UX

*d: Manufacturer and Description name show the following setting.

Name mode

Bit7	Bit6	Name mode
0	0	Ineffective
0	1	Apply to the Description and Manufacturer.
1	0	Apply to the Description.
1	1	ReservedAp

Customer name

Bit5	Bit4	Bit3	Bit2	Bit1	Bit0	Customer name
0	0		0	0	0	0
0	0	0	0	0	1	Acer
0	0	0	0	1	0	Apple
0	0	0	0	1	1	Compaq
0	0	0	1	0	0	Dell
0	0	0	1	0	1	eMachines
0	0	0	1	1	0	Fujitsu
0	0	0	1	1	1	Hewlett-Packard
0	0	1	0	0	0	IBM
0	0	1	0	0	1	Gateway
0	0	1	0	1	0	NEC
0	0	1	0	1	1	Panasonic
						Sharp
0	0	1	1	0	0	Sony
0	0	1	1	0	1	Toshiba
0	0	1	1	1	1	PHILIPS

*e: 0AH and 0BH are factory setting for Market specification.

Market	EEPROM address	EEPROM setting
Total print volumes 10,000 Pages (Except for ESP specification)	0A<H>	0B<H>
	0B<H>	7C<H>
Total print volumes 20,000 Pages (ESP specification)	0A<H>	00<H>
	0B<H>	00<H>

7.3 Component Layout

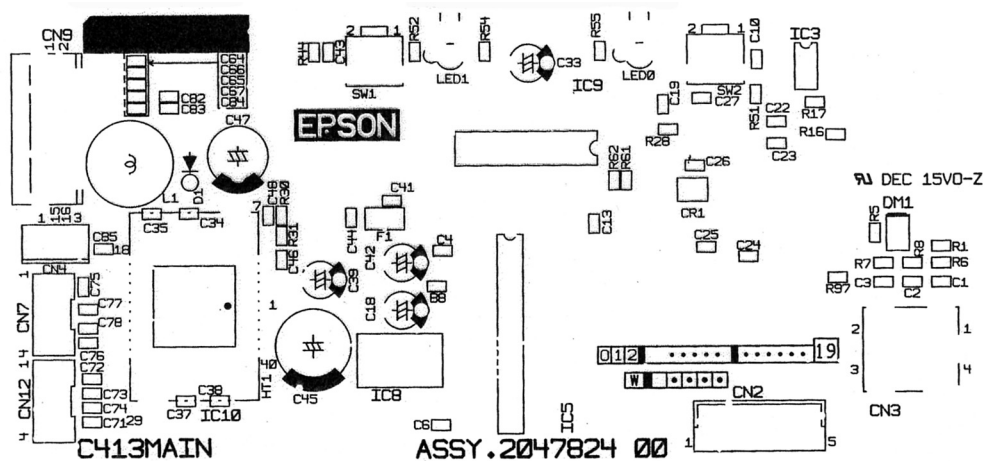


Figure 7-2. C413MAIN component layout

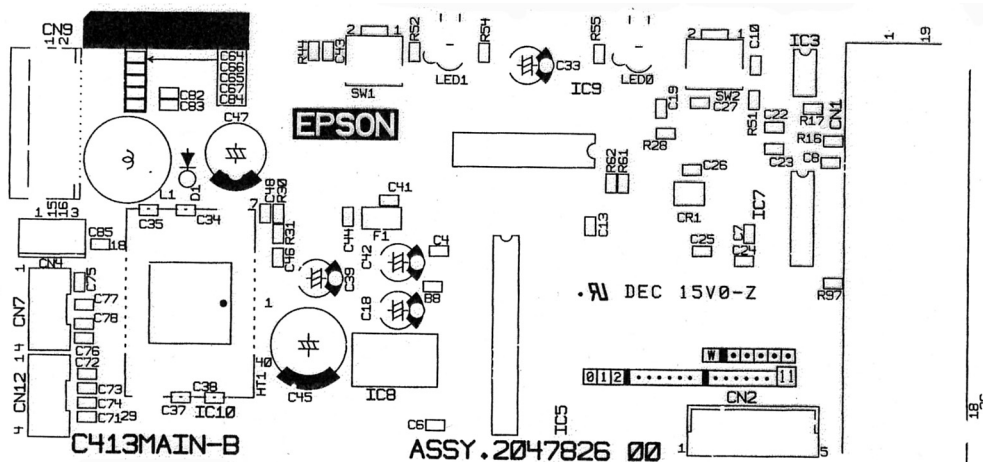


Figure 7-3. C413MAIN-B component layout

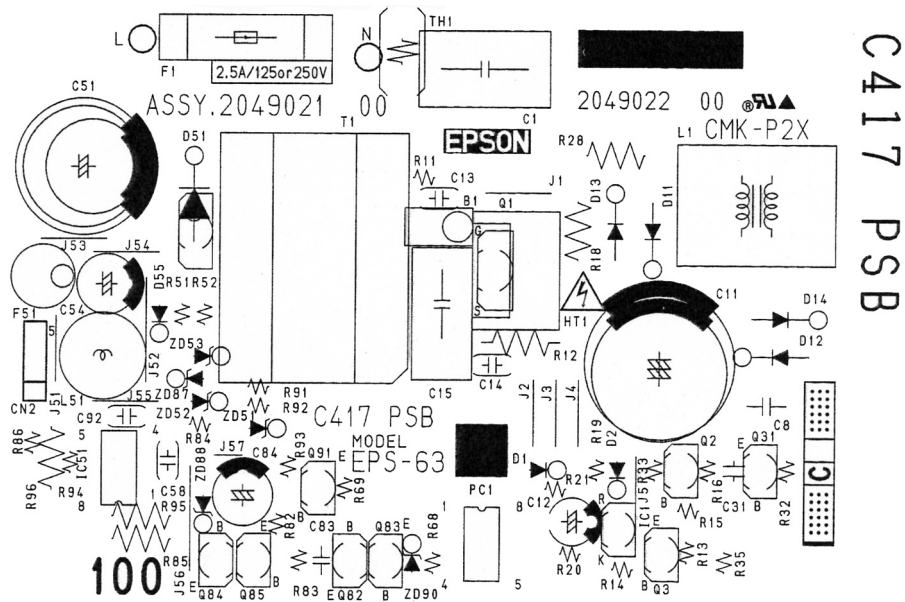


Figure 7-4. C417PSB component layout

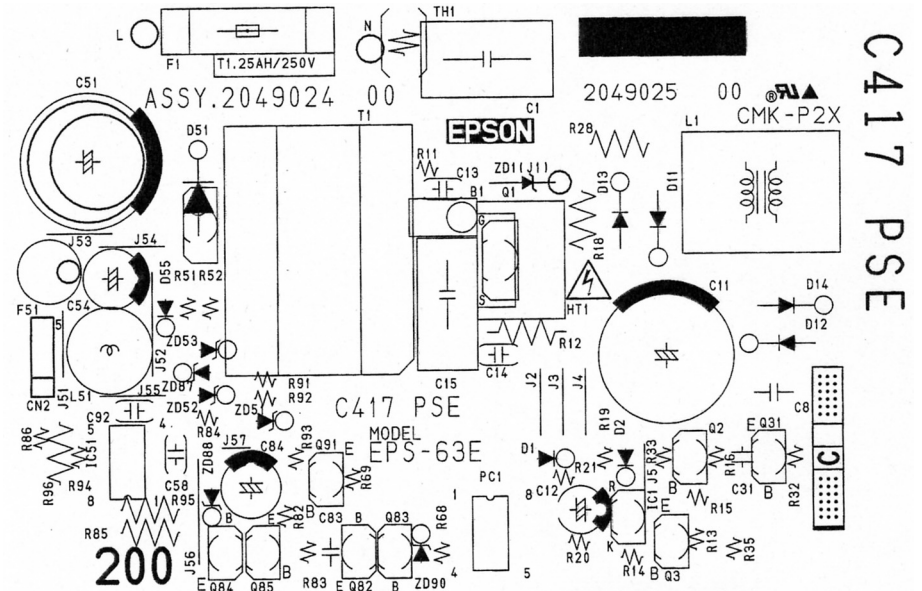


Figure 7-5. C417PSE component layout

7.4 Parts List

Table 7-8. parts list

Ref No.	Description
100	"HOUSING,UPPER,USB"
101	"COVER,PRINTER,USB"
102	PAPER SUPPORT
103	STACKER
104	LOGO PLATE 10X40;C
105	"BUTTON,SW"
200	"BOARD ASSY.,MAIN"
300	"POWER SUPPLY ASSY.,C413,ASP;120V"
500	PRINTER MECHANISM(ASP)MA410-101
501	PRINT HEAD
502	"HOLDER,I/C"
503	"COVER CARTRIDGE,BK"
504	"COVER CARTRIDGE,C"
505	"CABLE,HEAD"
506	"SHEET,PROTECT,CABLE HEAD"
507	"MOUNTING PLATE,M/B,ES2"
508	"HOLDER,SHAFT ASSY.,C413,ASP"
509	"MOTOR ASSY.,CR"
510	"HOUSING,LOWER"
511	FOOT
512	"FRAME,FRONT ASSY.,C413,ASP"
513	C.B.S. SCREW(B300204211)
600	"POROUSPAD,INKEJECT"

Table 7-8. parts list

Ref No.	Description
601	"POROUS PAD,TUBE,STOPPER"
602	"SHIELD PLATE,M/B"
603	"C.B.P-TITE SCREW,3X8,F/ZN"
604	C.B.S. SCREW(B300204211)
700	EDGE GUIDE
701	HOPPER
702	"PAD,HOPPER"
703	"COMPRESSION SPRING,2.50"
704	"FRAME,ASF"
705	"HOLDER,PAD"
706	"PAD,LD;D"
707	"TORSION SPRING,29.1"
708	C.B.S. SCREW(B300204211)
709	"C.B.P-TITE SCREW,3X8,F/ZN"
710	"C.B.S-TITE(P4),3X6,F/ZN"
01	INDIVIDUAL CARTON BOX FOR AMERICA
03	"PAD,PRINTER"
04	"PAD,ACCESSORY"
05	"PLASTIC PROTECTIVE BAG,360X680X0.03T"
06	PLASTIC PROTECTIVE BAG 180X260X0.03T
07	"PAD,CR"
NON FIG	"INK CARTRIDGE,B,OVERSEAS,AS"
NON FIG	"INK CARTRIDGE,C,OVERSEAS,AS"

7.5 Exploded Diagram

Following pages shows exploded diagram.

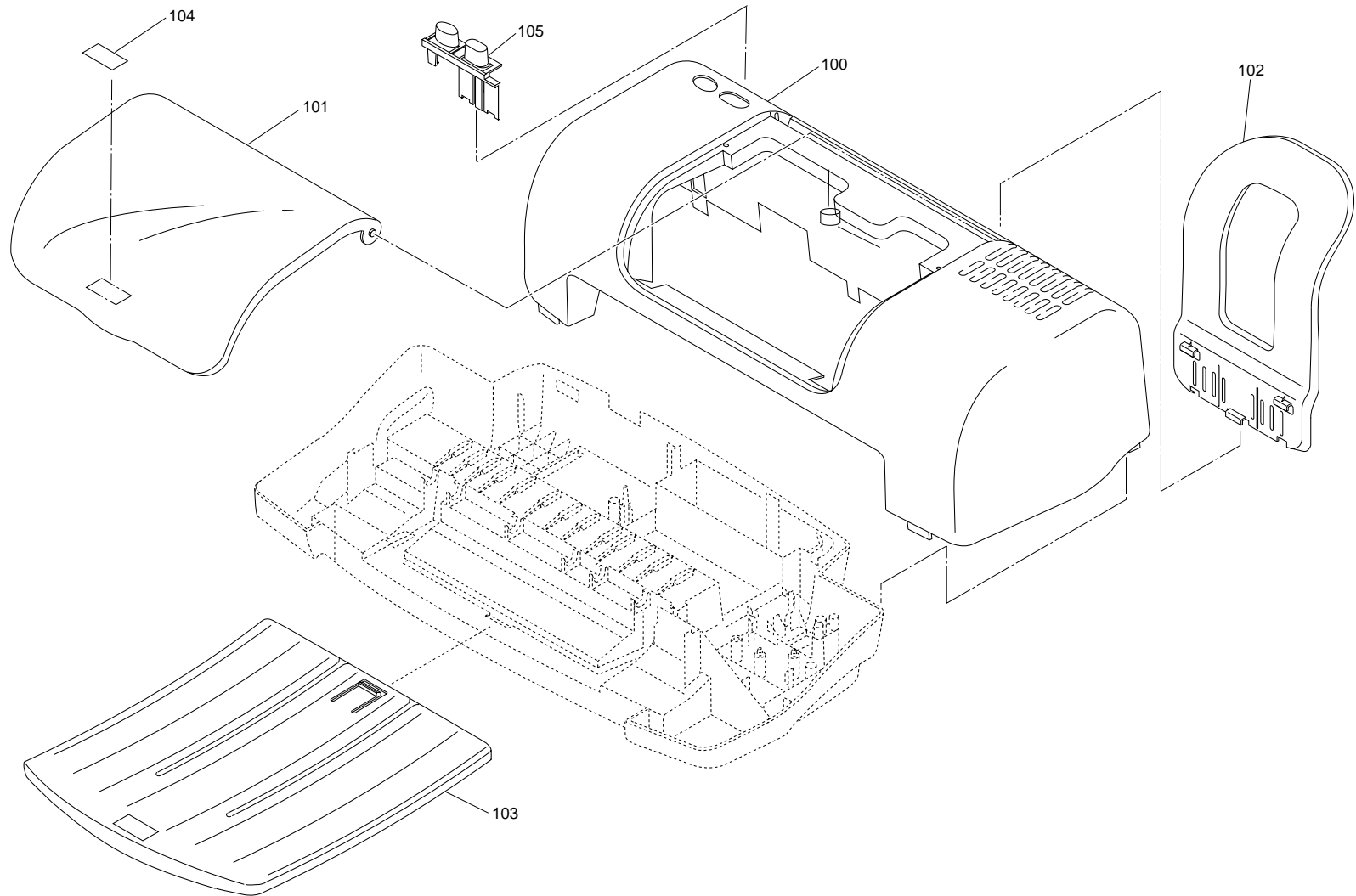


Figure 7-6. Stylus C40UX/C40SX/C20UX/C20SX Exploded Diagram 1

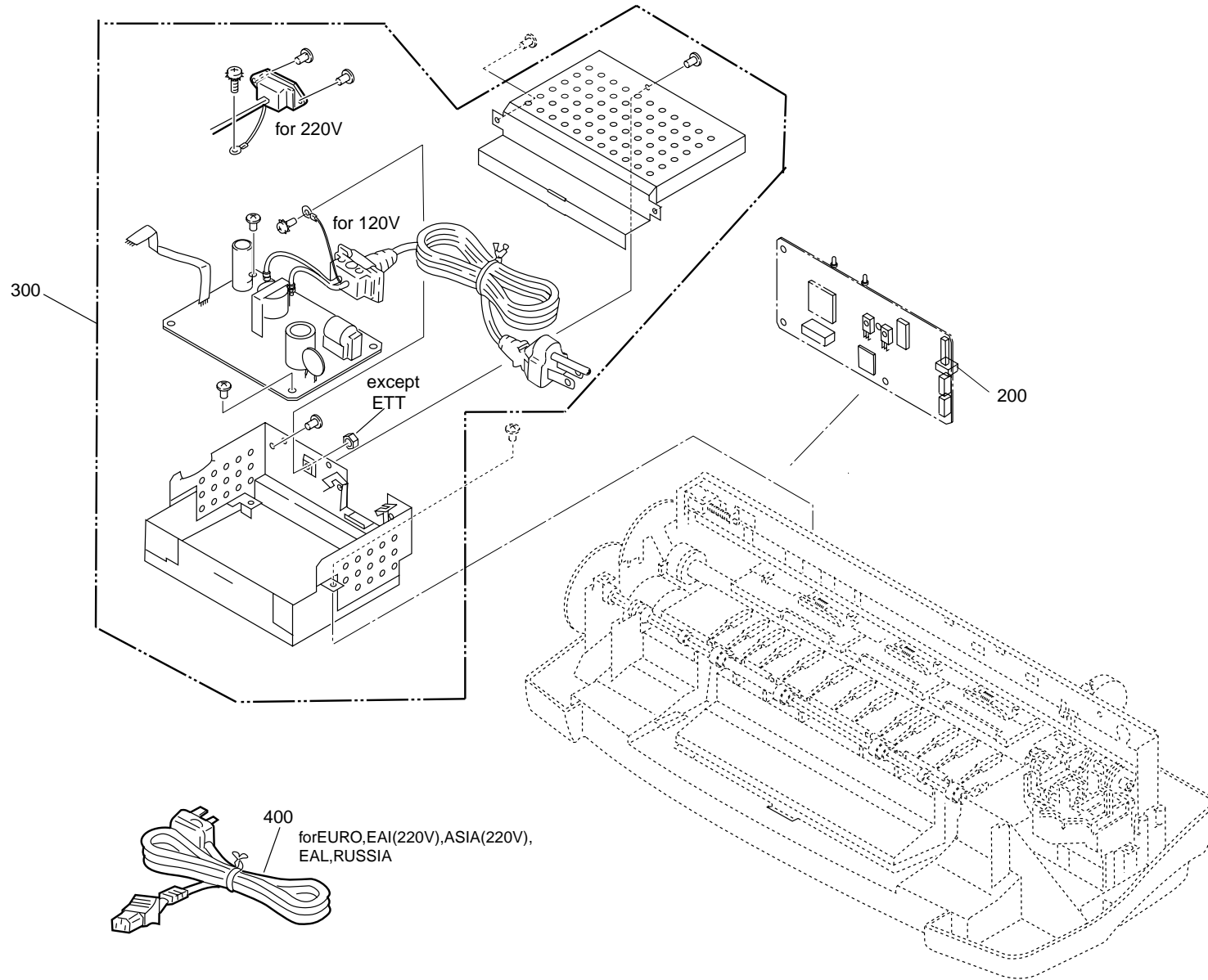


Figure 7-7. Stylus C40UX/C40SX/C20UX/C20SX Exploded Diagram 2

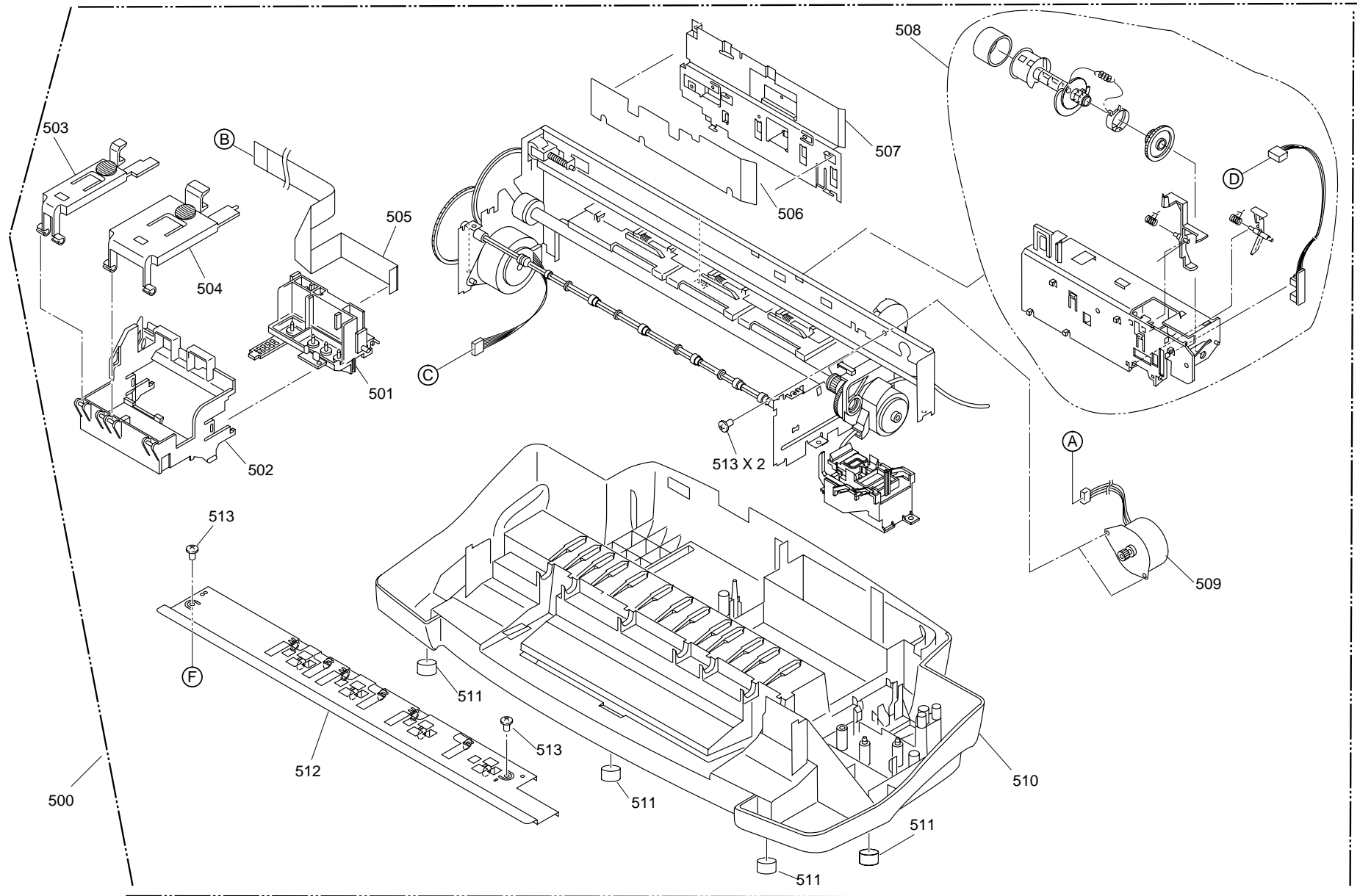


Figure 7-8. Stylus C40UX/C40SX/C20UX/C20SX Exploded Diagram 3

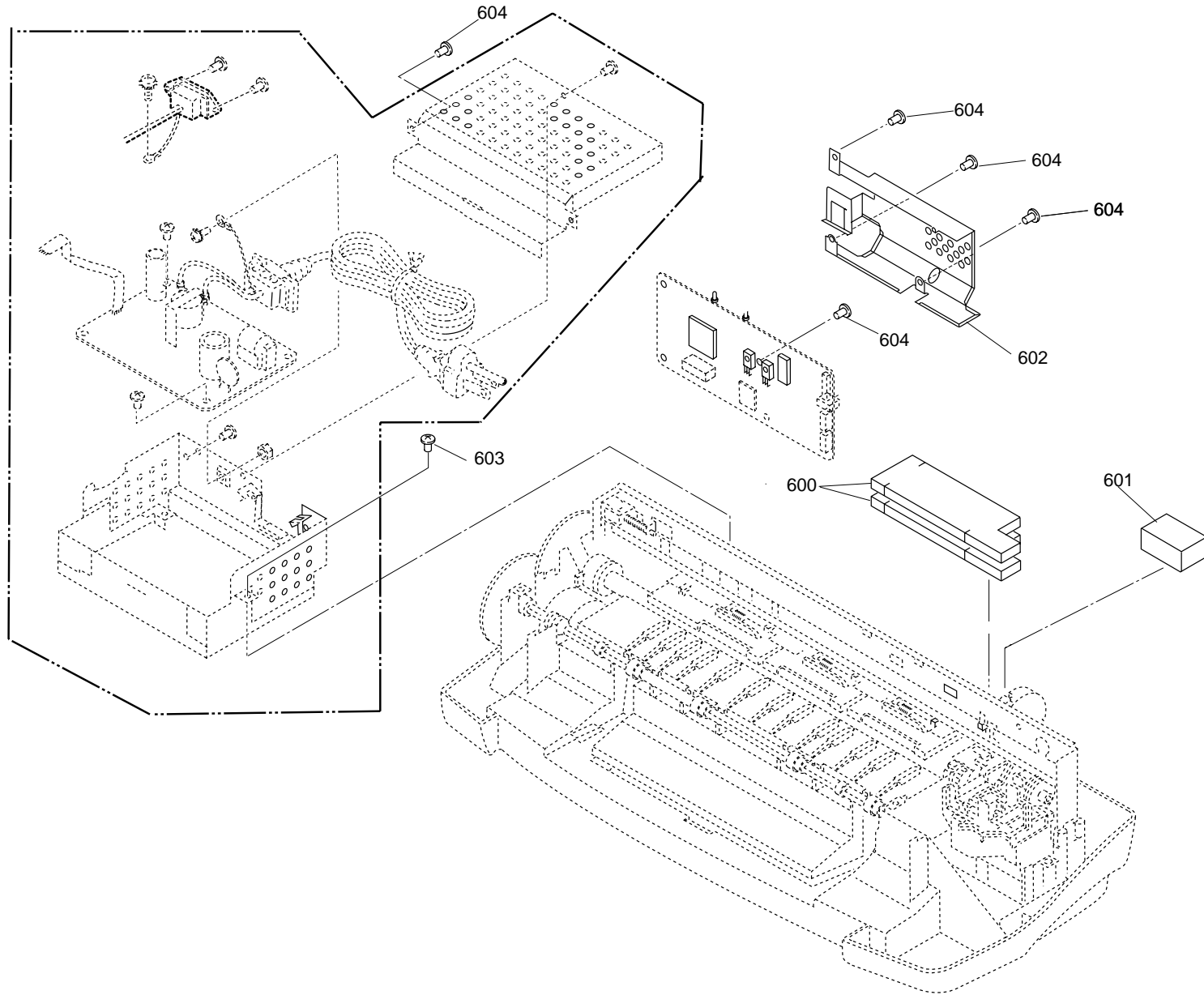


Figure 7-9. Stylus C40UX/C20UX Exploded Diagram 4

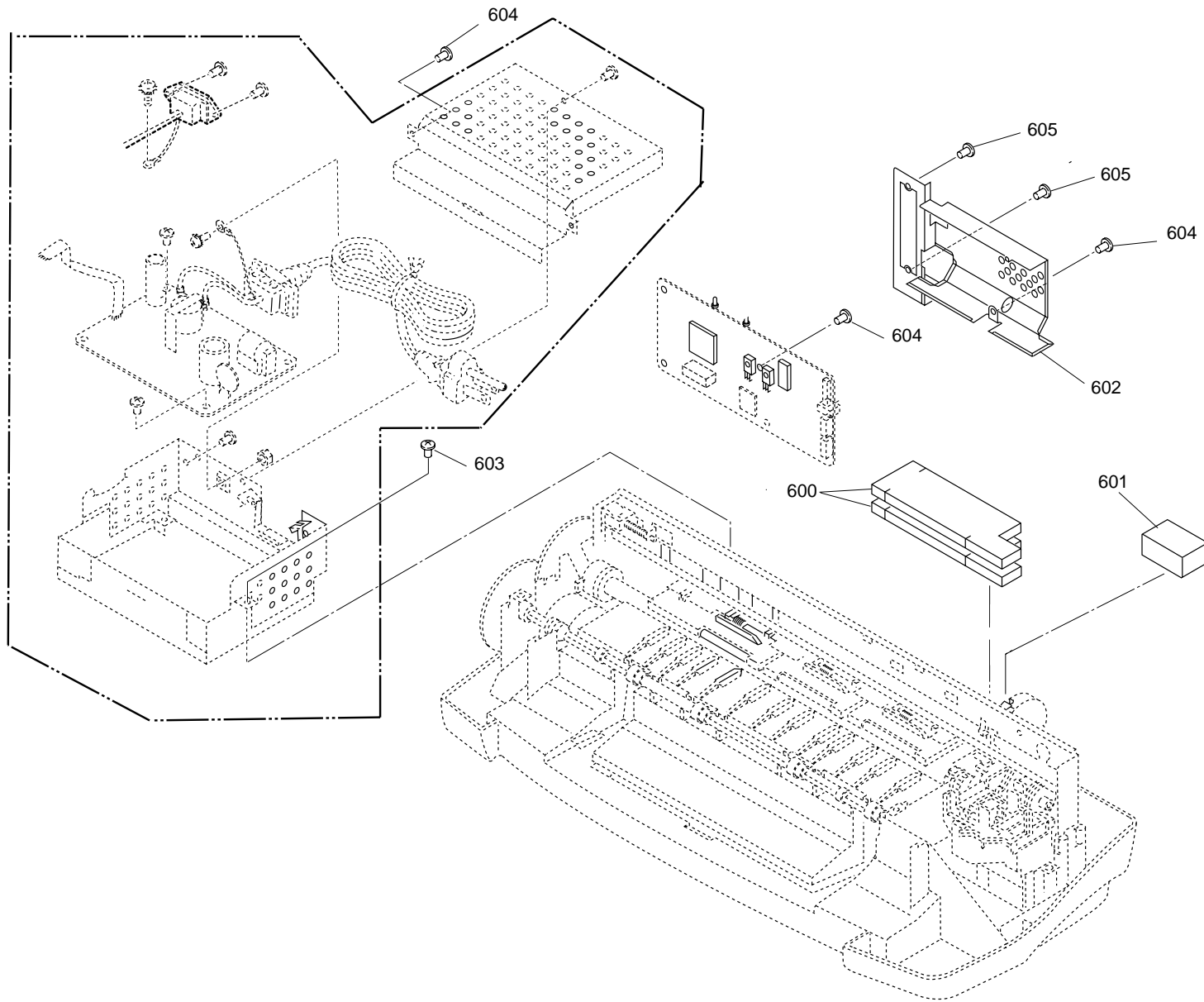


Figure 7-10. Stylus C40SX/C20SX Exploded Diagram 4

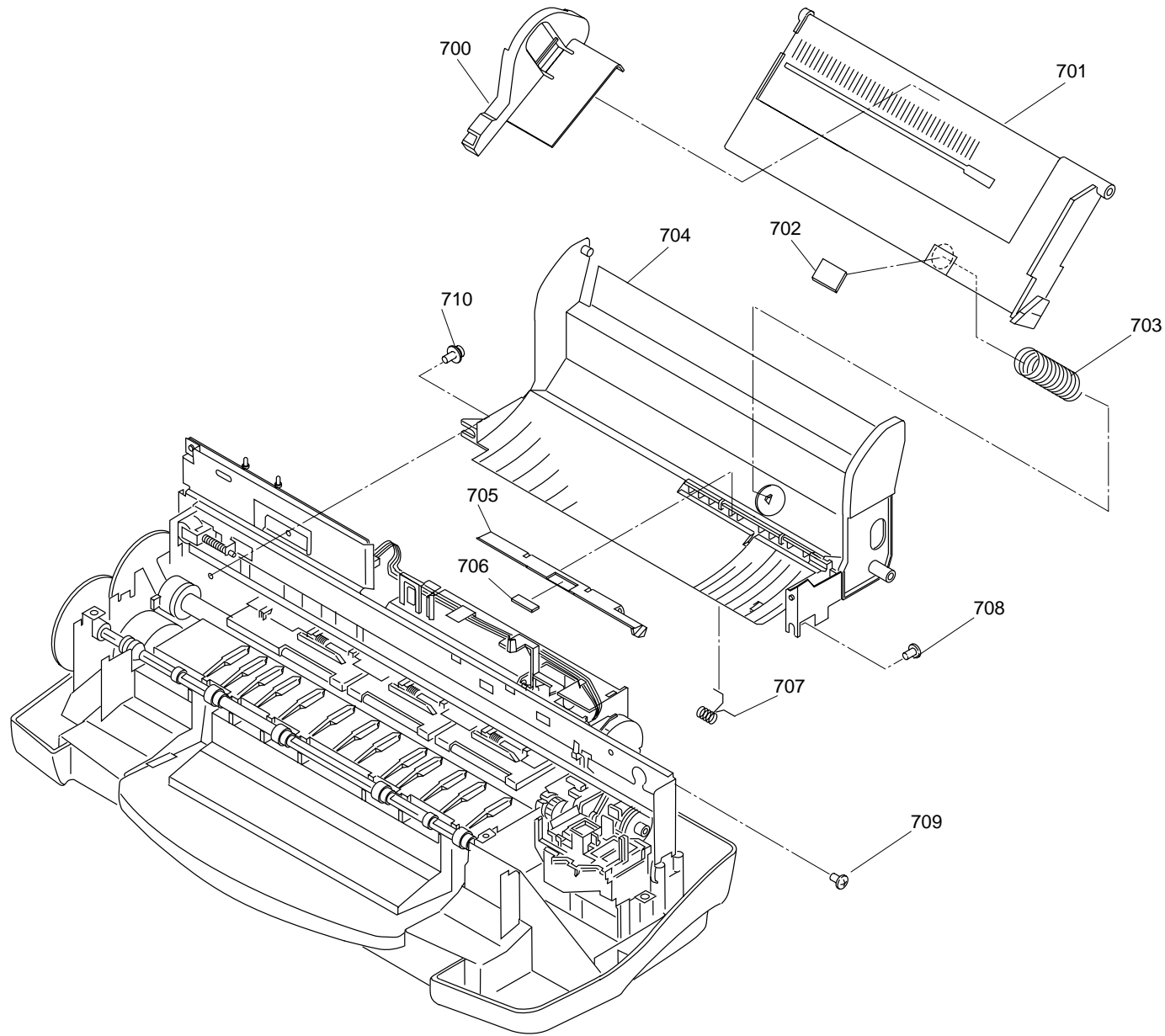
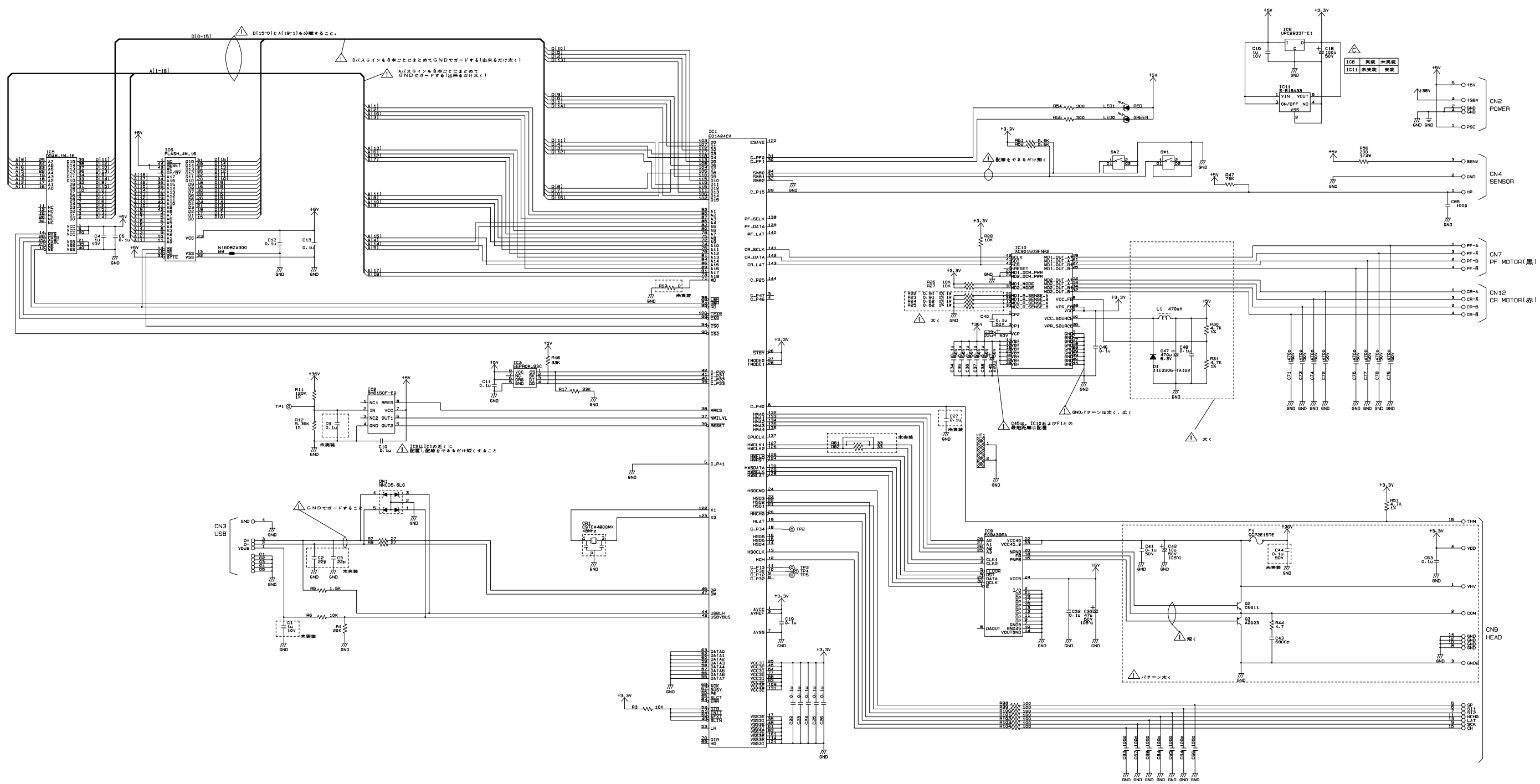


Figure 7-11. Stylus C40UX/C40SX/C20UX/C20SX Exploded Diagram 5

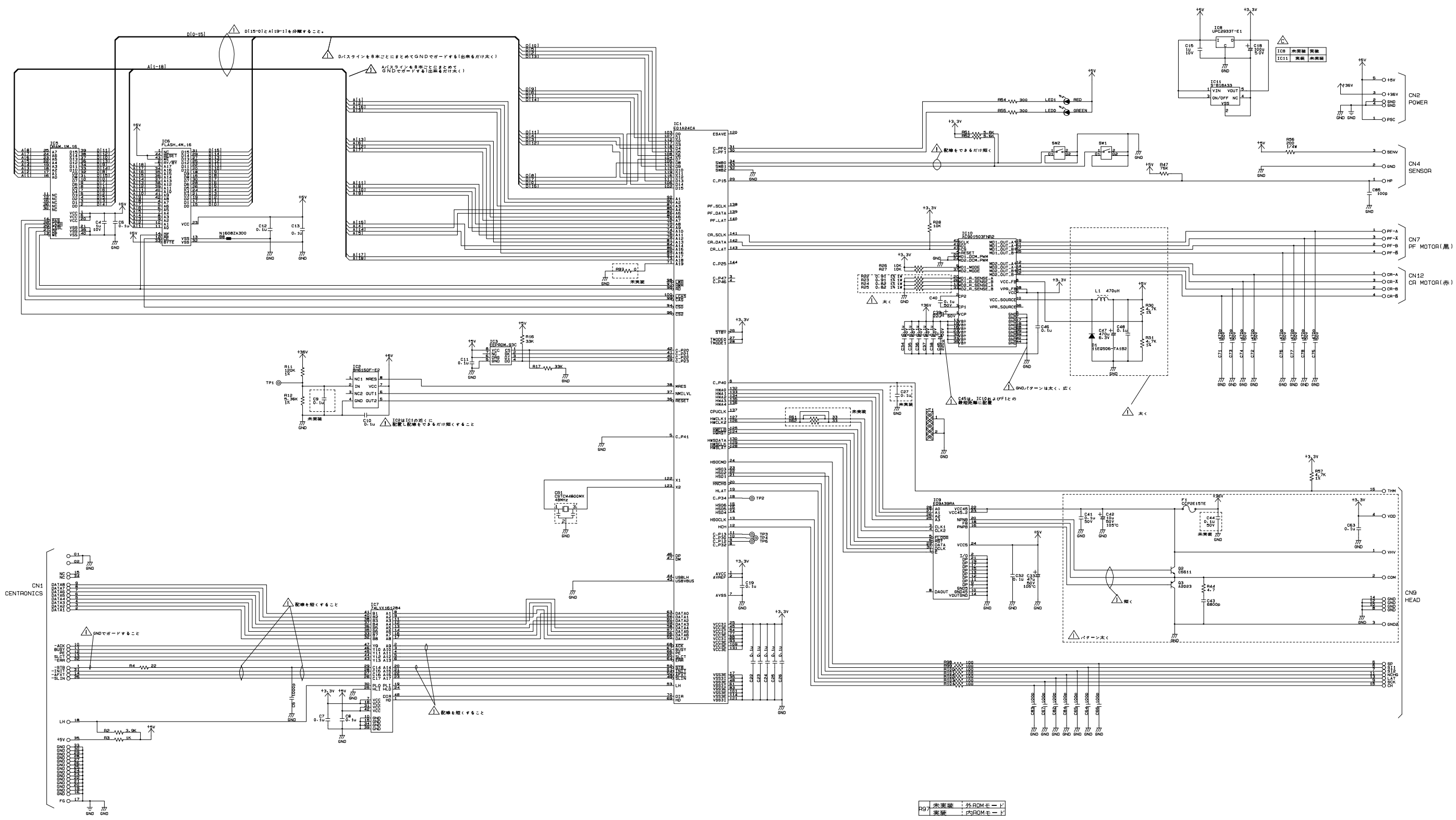
7.6 Electrical Circuits

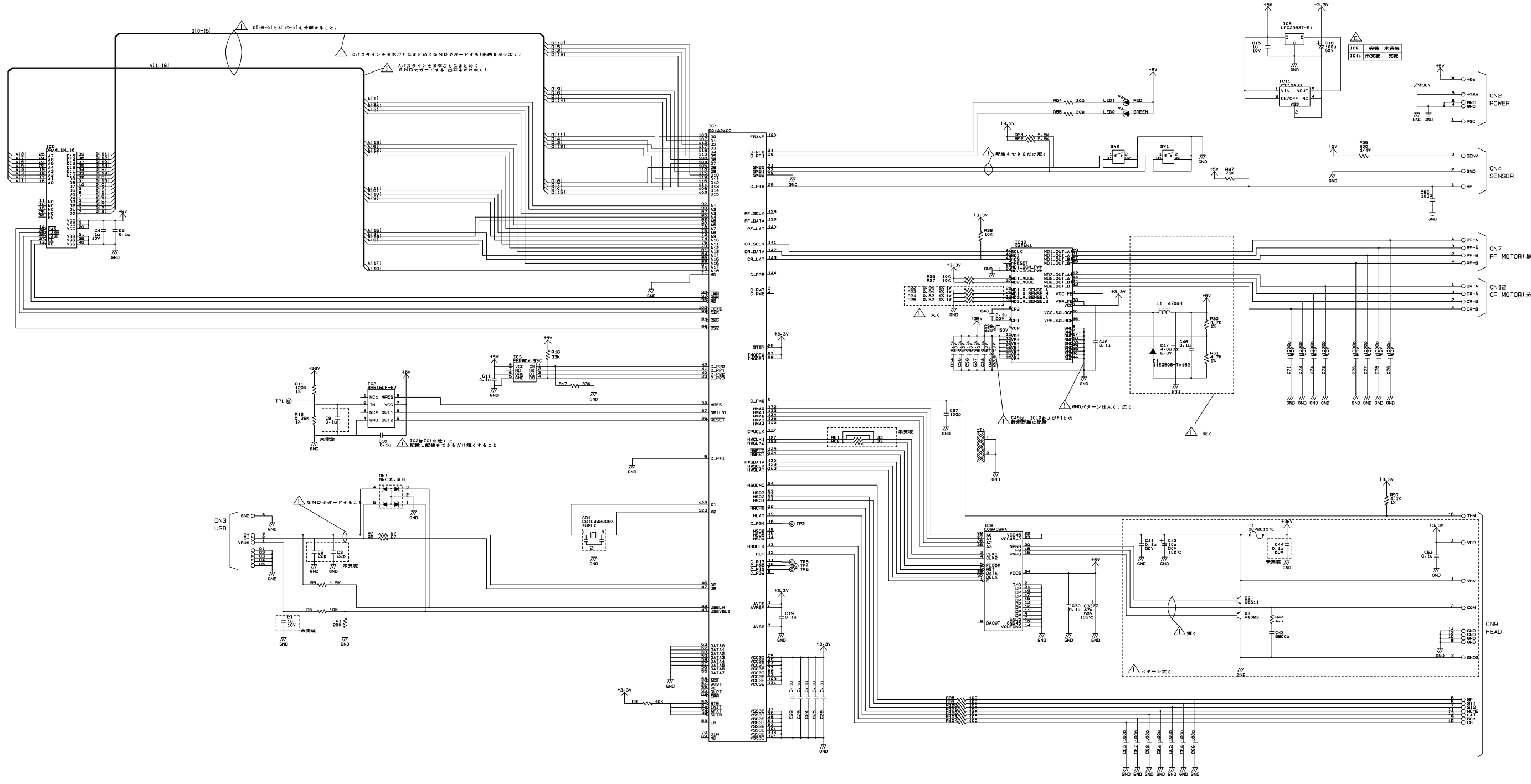
See the following pages for the electric circuit diagrams below:

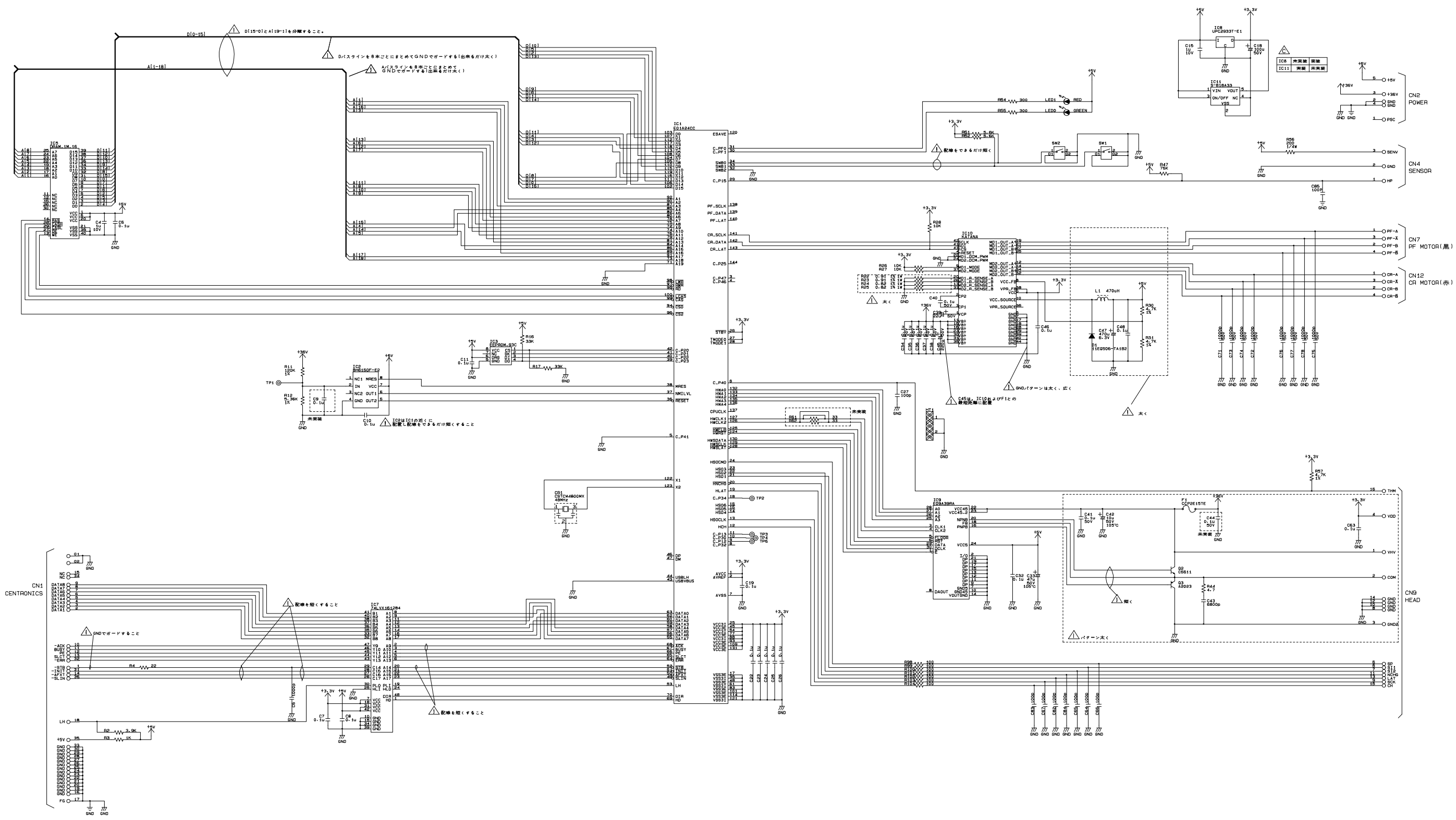
- C413MAIN control circuit board
- C413MAIN-B control circuit board
- C413MAIN-C control circuit board
- C413MAIN-D control circuit board
- C413PSB power supply circuit board
- C413PSE power supply circuit board



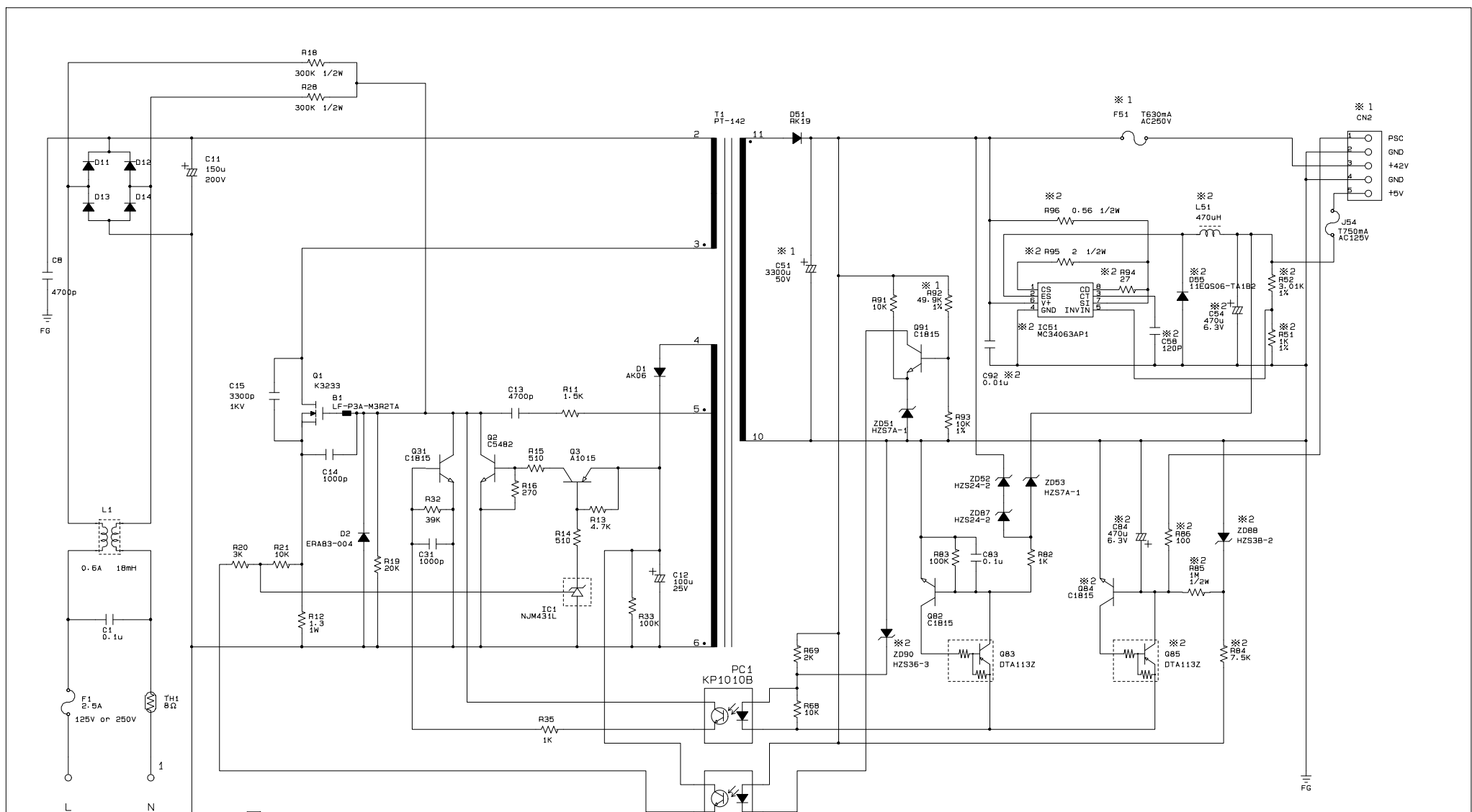
未実装 : 外ROMモード
 実装 : 内ROMモード







1
2
3
4
5
6

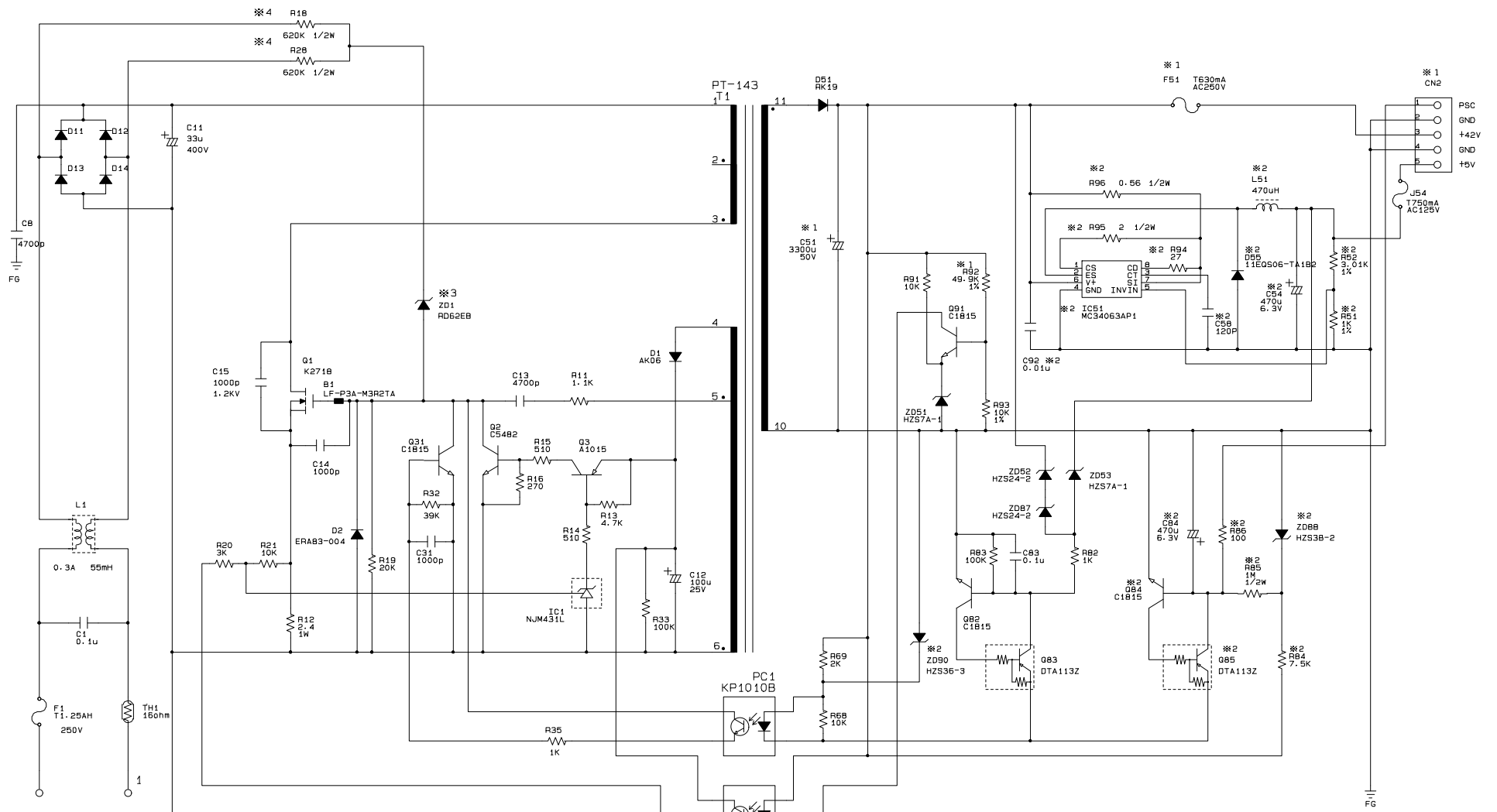


※ 1: 定数変更、その他

	C413	C417/C418
C51	1000 μ	3300 μ
F51	1.25A	630mA
R92	41.2K	49.9K
CN2 10pin	NC	PSC
CN2 3pin	+36V	+42V
J54	Jumper Wire	750mA 125V

※ 2: 下記アドレスについて、C413の場合は未実装、C417/C418の場合は実装とする。
 IC51: R51, R52, R84, R85, R86, R94, R95, R96, C54, C58, C84, C92, Q84, Q85, ZD88, ZD90, D55, L51

1
2
3
4
5
6



※ 1: 定数変更、その他

	C413	C417/C418
C51	1000 μ	3300 μ
F51	1.25A	630mA
R92	41.2K	49.9K
CN2 1pin	NC	P5C
CN2 3pin	+3EV	+42V
J54	Jumper wire	750mA 125V

※ 2: 下記アドレスについて、C413の場合は未実装、C417/C418の場合は実装とする。
IC51・R51・R52・R84・R85・R86・R94・R95・R96・C54・C58・C84・C92・Q84・Q85・ZD88・ZD90・D55・L51

※ 3: ZD1は韓国仕様のみ実装

※ 4: R18・R28は、韓国仕様は220K Ω ・1/2Wを実装、220-240V標準仕様は620K Ω ・1/2Wを実装