

Before You Begin

Dell™ Inspiron™ N5010/M5010 Service Manual

- [Recommended Tools](#)
- [Turning Off Your Computer](#)
- [Before Working Inside Your Computer](#)

This manual provides instructions for removing and installing components in your computer. Unless otherwise noted, each procedure assumes that the following conditions exist:

- You have performed the steps in [Turning Off Your Computer](#) and [Before Working Inside Your Computer](#).
- You have read the safety information that shipped with your computer.
- A component can be replaced or—if purchased separately—installed by performing the removal procedure in the reverse order.

Recommended Tools

The procedures in this document may require the following tools:

- Small flat-blade screwdriver
- Phillips screwdriver
- Plastic scribe
- BIOS executable update program available at support.dell.com

Turning Off Your Computer

 **CAUTION:** To avoid losing data, save and close all open files and exit all open programs before you turn off your computer.

1. Save and close all open files and exit all open programs.
2. Shut down the operating system:

Microsoft® Windows Vista®:

Click **Start**  , click the arrow  , and then click **Shut Down**.









Windows® 7:

Click **Start**  and then click **Shut Down**.

3. Ensure that the computer is turned off. If your computer did not automatically turn off when you shut down the operating system, press and hold the power button until the computer turns off.

Before Working Inside Your Computer

Use the following safety guidelines to help protect your computer from potential damage and to help to ensure your own personal safety.

-  **WARNING:** Before working inside your computer, read the safety information that shipped with your computer. For additional safety best practices information, see the Regulatory Compliance Homepage at www.dell.com/regulatory_compliance.
-  **CAUTION:** To avoid electrostatic discharge, ground yourself by using a wrist grounding strap or by periodically touching an unpainted metal surface (such as a connector on your computer).
-  **CAUTION:** Handle components and cards with care. Do not touch the components or contacts on a card. Hold a card by its edges or by its metal mounting bracket. Hold a component such as a processor by its edges, not by its pins.
-  **CAUTION:** Only a certified service technician should perform repairs on your computer. Damage due to servicing that is not authorized by Dell™ is not covered by your warranty.
-  **CAUTION:** When you disconnect a cable, pull on its connector or on its pull-tab, not on the cable itself. Some cables have connectors with locking tabs; if you are disconnecting this type of cable, press in on the locking tabs before you disconnect the cable. As you pull connectors apart, keep them evenly aligned to avoid bending any connector pins. Also, before you connect a cable, ensure that both connectors are correctly oriented and aligned.
-  **CAUTION:** To avoid damaging the computer, perform the following steps before you begin working inside the computer.
 1. Ensure that the work surface is flat and clean to prevent the computer cover from being scratched.
 2. Turn off your computer (see [Turning Off Your Computer](#)) and all attached devices.
-  **CAUTION:** To disconnect a network cable, first unplug the cable from your computer and then unplug the cable from the network device.
 3. Disconnect all telephone or network cables from the computer.
 4. Press and eject any installed cards from the 7-in-1 Media Card Reader.
 5. Disconnect your computer and all attached devices from their electrical outlets.
 6. Disconnect all attached devices from your computer.
-  **CAUTION:** To help prevent damage to the system board, remove the main battery (see [Removing the Battery](#)) before working inside the computer.

7. Remove the battery (see [Removing the Battery](#)).
8. Turn the computer top-side up, open the display, and press the power button to ground the system board.

Dell™ Inspiron™ N5010/M5010 Service Manual

[Before You Begin](#)

[Battery](#)

[Base Cover](#)

[Memory Module\(s\)](#)

[Optical Drive](#)

[Keyboard](#)

[Palm Rest](#)

[Wireless Mini-Card](#)

[Media Card Reader](#)

[Board](#)

[Hard Drive](#)

[Display](#)

[Camera Module](#)

[Internal Module With Bluetooth® Wireless Technology](#)

[Middle Cover](#)

[VGA Connector Board](#)

[System Board](#)

[Coin-Cell Battery](#)

[Processor Heat Sink](#)

[Processor Module](#)

[Speakers](#)

[I/O Board](#)

[Flashing the BIOS](#)

Notes, Cautions, and Warnings



NOTE: A NOTE indicates important information that helps you make better use of your computer.



CAUTION: A CAUTION indicates either potential damage to hardware or loss of data and tells you how to avoid the problem.



WARNING: A WARNING indicates a potential for property damage, personal injury, or death.

Information in this document is subject to change without notice.

© 2010 Dell Inc. All rights reserved.

Reproduction of these materials in any manner whatsoever without the written permission of Dell Inc. is strictly forbidden.

Trademarks used in this text: *Dell*, the *DELL* logo, and *Inspiron* are trademarks of Dell Inc.; *Bluetooth* is a registered trademark owned by Bluetooth SIG, Inc. and is used by Dell under license; *Microsoft*, *Windows*, *Windows Vista*, and the *Windows Vista* start button logo are either trademarks or registered trademarks of Microsoft Corporation in the United States and/or other countries.

Other trademarks and trade names may be used in this document to refer to either the entities claiming the marks and names or their products. Dell Inc. disclaims any proprietary interest in trademarks and trade names other than its own.

Regulatory model: P10F series

Regulatory type: P10F001; P10F002

March 2010 Rev. A00

Battery

Dell™ Inspiron™ N5010/M5010 Service Manual

- [Removing the Battery](#)
- [Replacing the Battery](#)

 **WARNING:** Before working inside your computer, read the safety information that shipped with your computer. For additional safety best practices information, see the Regulatory Compliance Homepage at www.dell.com/regulatory_compliance.

 **CAUTION:** Only a certified service technician should perform repairs on your computer. Damage due to servicing that is not authorized by Dell™ is not covered by your warranty.

 **CAUTION:** To avoid electrostatic discharge, ground yourself by using a wrist grounding strap or by periodically touching an unpainted metal surface (such as a connector on your computer).

 **CAUTION:** To avoid damage to the computer, use only the battery designed for this particular Dell computer. Do not use batteries designed for other Dell computers.

Removing the Battery

1. Follow the instructions in [Before You Begin](#).
2. Shut down the computer and turn it over.
3. Slide the battery lock latch to the unlock position.
4. Slide the battery release latch to the side.
5. Slide and lift the battery out of the battery bay.

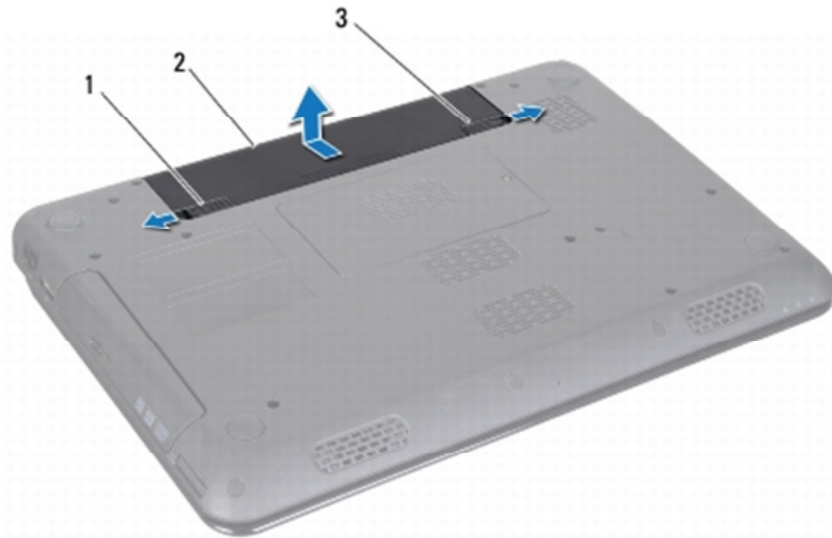

1	battery release latch	2	battery	3	battery lock latch
---	-----------------------	---	---------	---	--------------------

Replacing the Battery

1. Follow the instructions in [Before You Begin](#).
2. Align the tabs on the battery with the slots on the battery bay.
3. Slide the battery into the battery bay until it clicks into place.
4. Slide the battery lock latch to the lock position.

Base Cover

Dell™ Inspiron™ N5010/M5010 Service Manual

- [Removing the Base Cover](#)
- [Replacing the Base Cover](#)

⚠ WARNING: Before working inside your computer, read the safety information that shipped with your computer. For additional safety best practices information, see the Regulatory Compliance Homepage at www.dell.com/regulatory_compliance.

⚠ CAUTION: Only a certified service technician should perform repairs on your computer. Damage due to servicing that is not authorized by Dell™ is not covered by your warranty.

⚠ CAUTION: To avoid electrostatic discharge, ground yourself by using a wrist grounding strap or by periodically touching an unpainted metal surface (such as a connector on your computer).

⚠ CAUTION: To help prevent damage to the system board, remove the main battery (see [Removing the Battery](#)) before working inside the computer.

Removing the Base Cover

1. Follow the instructions in [Before You Begin](#).
2. Remove the battery (see [Removing the Battery](#)).
3. Loosen the captive screw that secures the base cover to the computer base.
4. Pry the base cover with your fingers and ensure that the base cover is released from the tabs on the computer base.
5. Lift the base cover off the computer base.

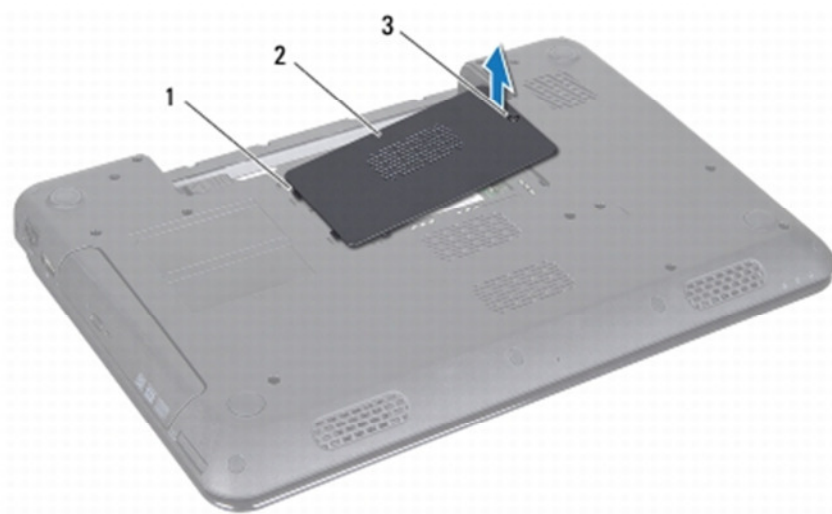

1	tabs (2)	2	base cover
3	captive screw		

Replacing the Base Cover

1. Follow the instructions in [Before You Begin](#).
2. Slide the two tabs on the base cover into the slots on the computer base.
3. Snap the base cover into place.
4. Tighten the captive screw that secures the base cover to the computer base.
5. Replace the battery (see [Replacing the Battery](#)).

 **CAUTION:** Before turning on the computer, replace all screws and ensure that no stray screws remain inside the computer. Failure to do so may result in damage to the computer.

Memory Module(s)

Dell™ Inspiron™ N5010/M5010 Service Manual

- [Removing the Memory Module\(s\)](#)
- [Replacing the Memory Module\(s\)](#)

 **WARNING:** Before working inside your computer, read the safety information that shipped with your computer. For additional safety best practices information, see the Regulatory Compliance Homepage at www.dell.com/regulatory_compliance.

 **CAUTION:** Only a certified service technician should perform repairs on your computer. Damage due to servicing that is not authorized by Dell™ is not covered by your warranty.

 **CAUTION:** To avoid electrostatic discharge, ground yourself by using a wrist grounding strap or by periodically touching an unpainted metal surface (such as a connector on your computer).

 **CAUTION:** To help prevent damage to the system board, remove the main battery (see [Removing the Battery](#)) before working inside the computer.

You can increase your computer memory by installing memory modules on the system board. See "Specifications" in your *Setup Guide* for information on the type of memory supported by your computer.

 **NOTE:** Memory modules purchased from Dell™ are covered under your computer warranty.

Your computer has two user-accessible SO-DIMM connectors, labeled DIMM A and DIMM B, that can be accessed from the bottom of the computer.

Removing the Memory Module(s)

1. Follow the instructions in [Before You Begin](#).
2. Remove the battery (see [Removing the Battery](#)).
3. Remove the base cover (see [Removing the Base Cover](#)).

 **CAUTION:** To prevent damage to the memory-module connector, do not use tools to spread the memory module securing clips.

4. Use your fingertips to carefully spread apart the securing clips on each end of the memory-module connector until the module pops up.
5. Remove the memory module from the memory-module connector.

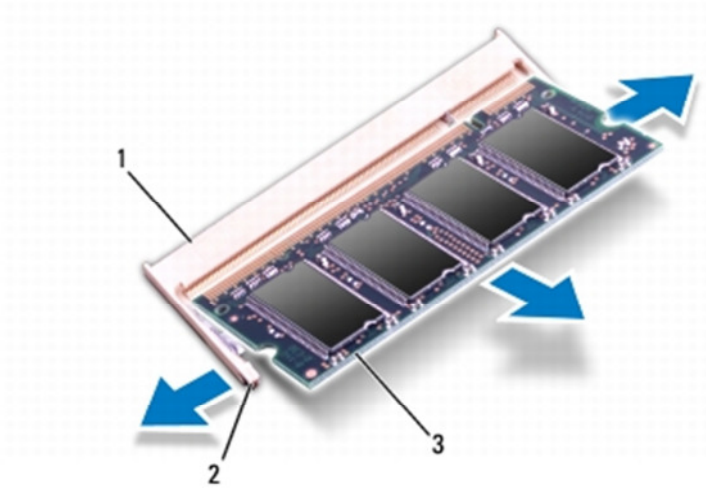

1	memory-module connector	2	securing clips (2)
3	memory module		

Replacing the Memory Module(s)

CAUTION: If you need to install memory modules in two connectors, install a memory module in the connector labeled "DIMM A" before you install a memory module in the connector labeled "DIMM B."

1. Follow the instructions in [Before You Begin](#).
2. Align the notch in the memory module with the tab in the memory-module connector.
3. Slide the memory module firmly into the connector at a 45-degree angle, and press the memory module down until it clicks into place. If you do not hear the click, remove the memory module and reinstall it.

NOTE: If the memory module is not installed properly, the computer may not boot.

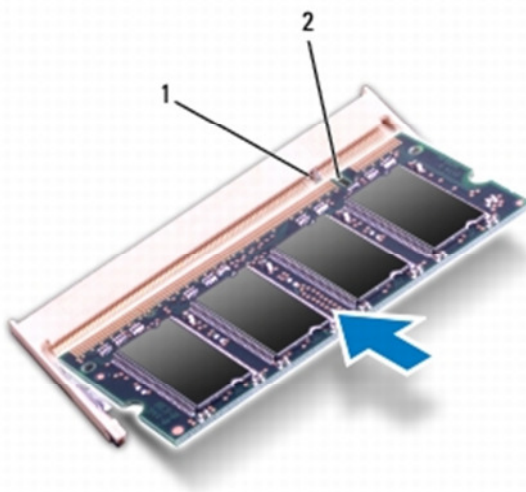

1	tab	2	notch
---	-----	---	-------

4. Replace the base cover (see [Replacing the Base Cover](#)).
5. Replace the battery (see [Replacing the Battery](#)), or connect the AC adapter to your computer and an electrical outlet.

 **CAUTION:** Before turning on the computer, replace all screws and ensure that no stray screws remain inside the computer. Failure to do so may result in damage to the computer.

6. Turn on the computer.

As the computer boots, it detects the memory module(s) and automatically updates the system configuration information.

To confirm the amount of memory installed in the computer:

Windows Vista®:

Click **Start**  → **Help and Support** → **Dell System Information**.

Windows® 7:

Click **Start**  → **Control Panel** → **System and Security** → **System**.

Optical Drive

Dell™ Inspiron™ N5010/M5010 Service Manual

- [Removing the Optical Drive](#)
- [Replacing the Optical Drive](#)

 **WARNING:** Before working inside your computer, read the safety information that shipped with your computer. For additional safety best practices information, see the Regulatory Compliance Homepage at www.dell.com/regulatory_compliance.

 **CAUTION:** Only a certified service technician should perform repairs on your computer. Damage due to servicing that is not authorized by Dell™ is not covered by your warranty.

 **CAUTION:** To avoid electrostatic discharge, ground yourself by using a wrist grounding strap or by periodically touching an unpainted metal surface (such as a connector on your computer).

 **CAUTION:** To help prevent damage to the system board, remove the main battery (see [Removing the Battery](#)) before working inside the computer.

Removing the Optical Drive

1. Follow the instructions in [Before You Begin](#).

2. Remove the battery (see [Removing the Battery](#)).
3. Remove the base cover (see [Removing the Base Cover](#)).
4. Remove the screw that secures the optical drive to the computer base.
5. Using a plastic scribe, push the notch to remove the optical drive from the optical drive bay.
6. Slide the optical drive out of the optical drive bay.

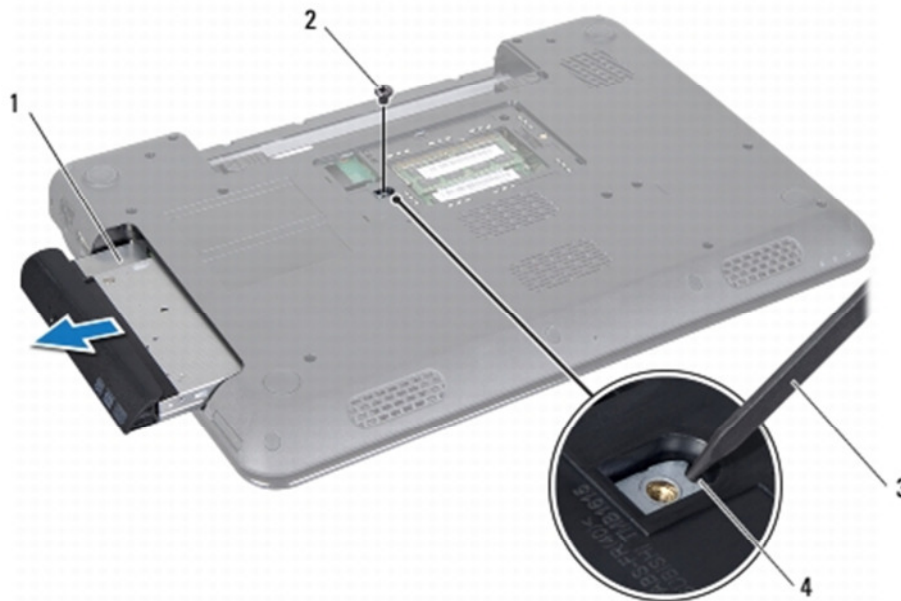

1	optical drive	2	screw
3	plastic scribe	4	notch

Replacing the Optical Drive

1. Follow the instructions in [Before You Begin](#).
2. Slide the optical drive into the optical drive bay until it is fully seated.
3. Replace the screw that secures the optical drive to the computer base.
4. Replace the base cover (see [Replacing the Base Cover](#)).
5. Replace the battery (see [Replacing the Battery](#)).

CAUTION: Before turning on the computer, replace all screws and ensure that no stray screws remain inside the computer. Failure to do so may result in damage to the computer.

Keyboard

Dell™ Inspiron™ N5010/M5010 Service Manual

- [Removing the Keyboard](#)
- [Replacing the Keyboard](#)

 **WARNING:** Before working inside your computer, read the safety information that shipped with your computer. For additional safety best practices information, see the Regulatory Compliance Homepage at www.dell.com/regulatory_compliance.

 **CAUTION:** Only a certified service technician should perform repairs on your computer. Damage due to servicing that is not authorized by Dell™ is not covered by your warranty.

 **CAUTION:** To avoid electrostatic discharge, ground yourself by using a wrist grounding strap or by periodically touching an unpainted metal surface (such as a connector on your computer).

 **CAUTION:** To help prevent damage to the system board, remove the main battery (see [Removing the Battery](#)) before working inside the computer.

Removing the Keyboard

1. Follow the instructions in [Before You Begin](#).
2. Remove the battery (see [Removing the Battery](#)).
3. Turn the computer over and open the display as far as possible.

 **CAUTION:** The keycaps on the keyboard are fragile, easily dislodged, and time-consuming to replace. Be careful when removing and handling the keyboard.

4. Press the keyboard and slide it towards the bottom as far as possible.
5. Slide a plastic scribe between the keyboard and palm rest, and pry and lift the keyboard to disengage it from the tabs on the palm rest.

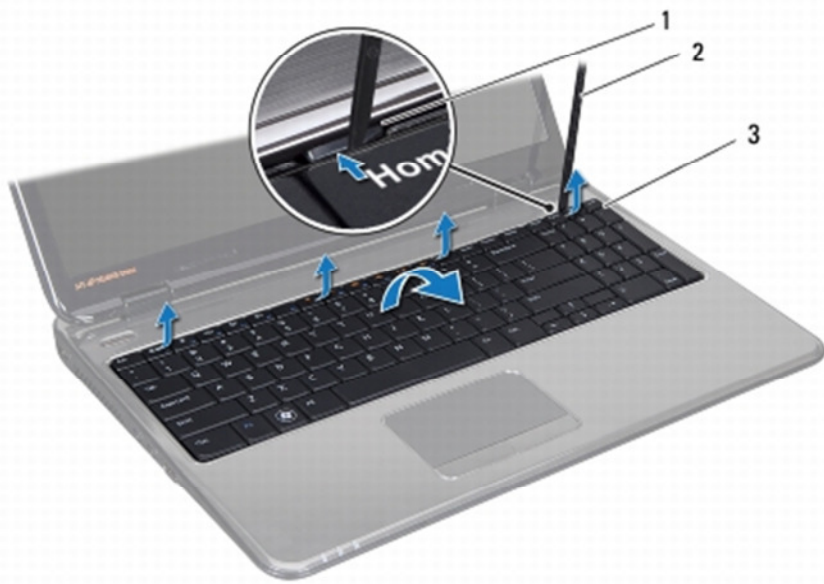

1	palm rest tabs (4)	2	plastic scribe
3	keyboard		

6. Ease the keyboard up and slide the six tabs at the bottom of the keyboard out of the slots on the palm rest.
7. Without pulling hard on the keyboard, turn it over.
8. Lift the connector latch and pull the pull-tab to disconnect the keyboard cable from the connector on the system board.
9. Lift the keyboard off the computer.



1	connector latch	2	keyboard tabs (6)
---	-----------------	---	-------------------

Replacing the Keyboard

1. Follow the instructions in [Before You Begin](#).
2. Slide the keyboard cable into the connector on the system board and press down on the connector latch to secure the cable.
3. Slide the six tabs at the bottom of the keyboard into the slots on the palm rest.
4. Gently press around the edges of the keyboard to secure the keyboard under the tabs on the palm rest and slide the keyboard upwards.
5. Replace the battery (see [Replacing the Battery](#)).

 **CAUTION:** Before turning on the computer, replace all screws and ensure that no stray screws remain inside the computer. Failure to do so may result in damage to the computer.

Palm Rest

Dell™ Inspiron™ N5010/M5010 Service Manual

- [Removing the Palm Rest](#)
- [Replacing the Palm Rest](#)

 **WARNING:** Before working inside your computer, read the safety information that shipped with your computer. For additional safety best practices information, see the Regulatory Compliance Homepage at www.dell.com/regulatory_compliance.

 **CAUTION:** Only a certified service technician should perform repairs on your computer. Damage due to servicing that is not authorized by Dell™ is not covered by your warranty.

 **CAUTION:** To avoid electrostatic discharge, ground yourself by using a wrist grounding strap or by periodically touching an unpainted metal surface (such as a connector on your computer).

 **CAUTION:** To help prevent damage to the system board, remove the main battery (see [Removing the Battery](#)) before working inside the computer.

Removing the Palm Rest

1. Follow the instructions in [Before You Begin](#).
2. Remove the battery (see [Removing the Battery](#)).
3. Remove the base cover (see [Removing the Base Cover](#)).
4. Remove the memory module(s) (see [Removing the Memory Module\(s\)](#)).
5. Remove the optical drive (see [Removing the Optical Drive](#)).

6. Remove the four rubber screw caps that cover the screws.

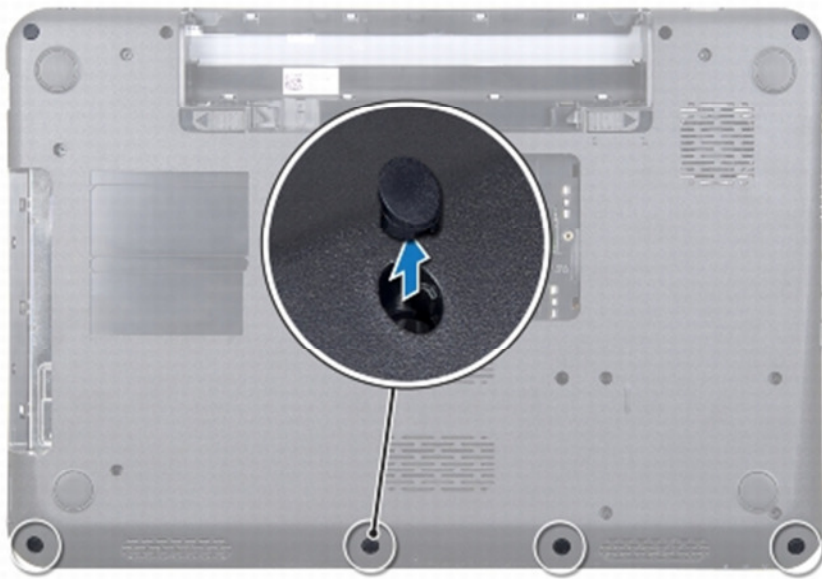

7. Remove the seven screws that secure the palm rest to the computer base.

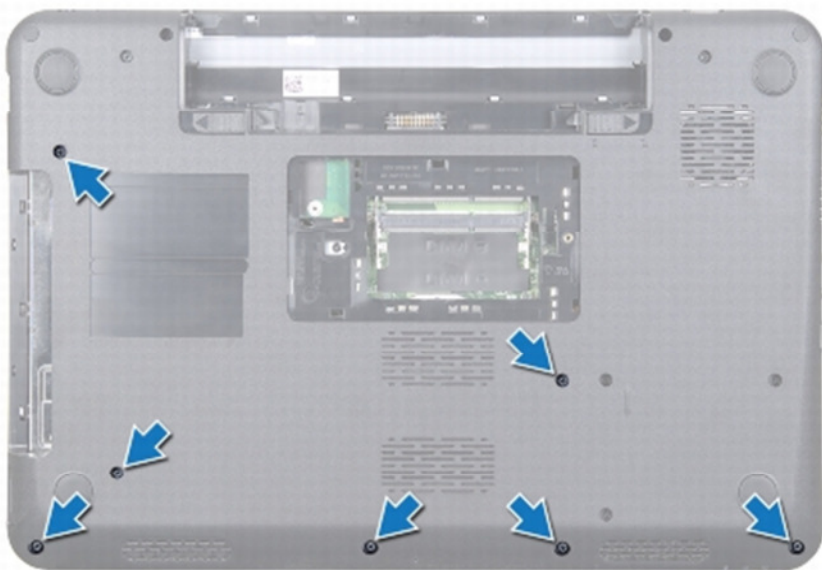

8. Remove the keyboard (see [Removing the Keyboard](#)).

⚠ CAUTION: To avoid damage to the connectors, lift the connector latch and then remove the cables.

9. Disconnect the touch pad cable, status light cable, and power button cable from the connectors on the system board.
10. Remove the five screws that secure the palm rest to the system board.

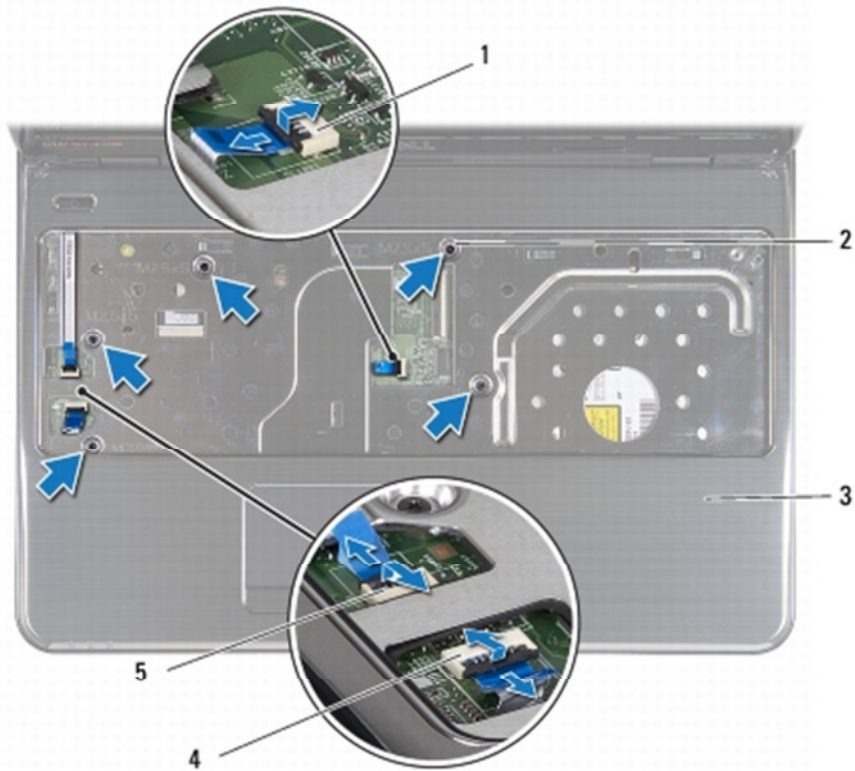

1	touch pad cable connector	2	screw
3	palm rest	4	status light cable connector
5	power button cable connector		

⚠ CAUTION: Carefully separate the palm rest from the computer base to avoid damage to the palm rest.

11. Slide a plastic scribe between the computer base and the palm rest and pry out the palm rest off the computer base.



1	palm rest	2	plastic scribe
---	-----------	---	----------------

Replacing the Palm Rest

1. Follow the instructions in [Before You Begin](#).
2. Slide the tabs on the palm rest into the slots on the computer base and gently snap the palm rest into place.
3. Replace the five screws that secure the palm rest to the system board.
4. Connect the touch pad cable, status light cable, and power button cable to the connectors on the system board.
5. Replace the keyboard (see [Replacing the Keyboard](#)).
6. Turn the computer over and replace the seven screws that secure the palm rest to the computer base.
7. Replace the four rubber screw caps that cover the screws.
8. Replace the optical drive (see [Replacing the Optical Drive](#)).
9. Replace the memory module(s) (see [Replacing the Memory Module\(s\)](#)).
10. Replace the base cover (see [Replacing the Base Cover](#)).
11. Replace the battery (see [Replacing the Battery](#)).

 **CAUTION:** Before turning on the computer, replace all screws and ensure that no stray screws remain inside the computer. Failure to do so may result in damage to the computer.

Wireless Mini-Card

Dell™ Inspiron™ N5010/M5010 Service Manual

 [Removing the Mini-Card](#)

 [Replacing the Mini-Card](#)

 **WARNING:** Before working inside your computer, read the safety information that shipped with your computer. For additional safety best practices information, see the Regulatory Compliance Homepage at www.dell.com/regulatory_compliance.

 **CAUTION:** Only a certified service technician should perform repairs on your computer. Damage due to servicing that is not authorized by Dell™ is not covered by your warranty.

 **CAUTION:** To avoid electrostatic discharge, ground yourself by using a wrist grounding strap or by periodically touching an unpainted metal surface (such as a connector on your computer).

 **CAUTION:** To help prevent damage to the system board, remove the main battery (see [Removing the Battery](#)) before working inside the computer.

 **CAUTION:** When the Mini-Card is not in the computer, store it in protective antistatic packaging (see "Protecting Against Electrostatic Discharge" in the safety instructions that shipped with your computer).

 **NOTE:** Dell does not guarantee compatibility or provide support for Mini-Cards from sources other than Dell.

If you ordered a wireless Mini-Card with your computer, the card is already installed.

Your computer supports one half Mini-Card slot:

- One half Mini-Card slot — For Wireless Local Area Network (WLAN), Wi-Fi, or Worldwide Interoperability for Microwave Access (WiMax)

 **NOTE:** Depending on the configuration of the computer when it was sold, the Mini-Card slot may or may not have a Mini-Card installed in it.

Removing the Mini-Card

1. Follow the instructions in [Before You Begin](#).
2. Remove the battery (see [Removing the Battery](#)).
3. Remove the base cover (see [Removing the Base Cover](#)).
4. Remove memory module(s) (see [Removing the Memory Module\(s\)](#)).
5. Remove the optical drive (see [Removing the Optical Drive](#)).
6. Remove the keyboard (see [Removing the Keyboard](#)).
7. Remove the palm rest (see [Removing the Palm Rest](#)).

 **CAUTION:** When you disconnect a cable, pull on its connector or on its pull-tab, not on the cable itself. Some cables have connectors with locking tabs; if you are disconnecting this type of cable, press in on the locking tabs before you disconnect the cable. As you pull connectors apart, keep them evenly aligned to avoid bending any connector pins. Also, before you connect a cable, ensure that both connectors are correctly oriented and aligned.

8. Disconnect the antenna cables from the Mini-Card.

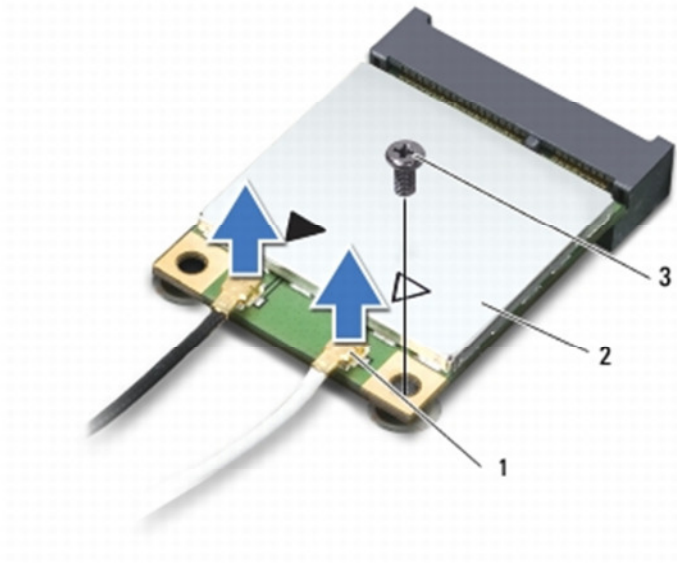

1	antenna cable connectors (2)	2	Mini-Card	3	screw
---	------------------------------	---	-----------	---	-------

9. Remove the screw that secures the Mini-Card to the connector on the system board.

10. Lift the Mini-Card out of the connector on the system board.

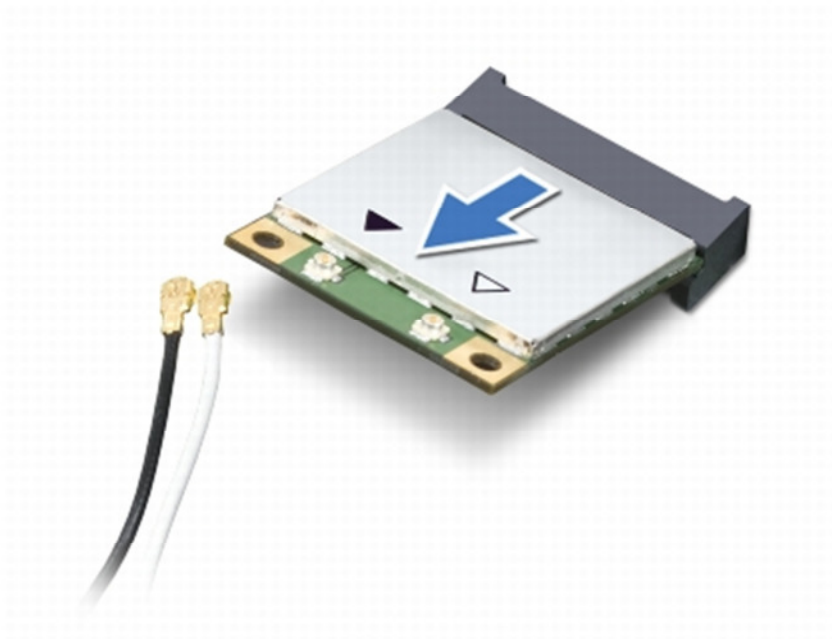

Replacing the Mini-Card

1. Follow the instructions in [Before You Begin](#).
2. Remove the new Mini-Card from its packaging.

 **CAUTION:** Use firm and even pressure to slide the card into place. If you use

excessive force, you may damage the connector.

 **CAUTION:** The connectors are keyed to ensure correct insertion. If you feel resistance, check the connectors on the card and on the system board, and realign the card.

 **CAUTION:** To avoid damage to the Mini-Card, never place cables under the card.

3. Insert the Mini-Card connector at a 45-degree angle into the connector on the system board.
4. Press the other end of the Mini-Card down into the slot on the system board and replace the screw that secures the Mini-Card to the connector on the system board.
5. Connect the appropriate antenna cables to the Mini-Card you are installing. The following table provides the antenna cable color scheme for the Mini-Card supported by your computer.

Connectors on the Mini-Card	Antenna Cable Color Scheme
WLAN, Wi-Fi, WiMax (2 antenna cables)	
Main (white triangle)	white
Auxiliary (black triangle)	black

6. Secure the unused antenna cables in the protective mylar sleeve.
7. Replace the palm rest (see [Replacing the Palm Rest](#)).
8. Replace the keyboard (see [Replacing the Keyboard](#)).
9. Replace the optical drive (see [Replacing the Optical Drive](#)).
10. Replace memory module(s) (see [Replacing the Memory Module\(s\)](#)).
11. Replace the base cover (see [Replacing the Base Cover](#)).
12. Replace the battery (see [Replacing the Battery](#)).

 **CAUTION:** Before turning on the computer, replace all screws and ensure that no stray screws remain inside the computer. Failure to do so may result in damage to the computer.

13. Install the drivers and utilities for your computer, as required. For more information, see the *Dell Technology Guide*.

 **NOTE:** If you are installing a wireless Mini-Card from a source other than Dell, you must install the appropriate drivers and utilities. For more generic driver information, see the *Dell Technology Guide*.

Media Card Reader Board

Dell™ Inspiron™ N5010/M5010 Service Manual

- [Removing the Media Card Reader Board](#)
- [Replacing the Media Card Reader Board](#)

 **WARNING:** Before working inside your computer, read the safety information that shipped with your computer. For additional safety best practices information, see the Regulatory Compliance Homepage at www.dell.com/regulatory_compliance.

 **CAUTION:** Only a certified service technician should perform repairs on your computer. Damage due to servicing that is not authorized by Dell™ is not covered by your warranty.

 **CAUTION:** To avoid electrostatic discharge, ground yourself by using a wrist grounding strap or by periodically touching an unpainted metal surface (such as a connector on your computer).

 **CAUTION:** To help prevent damage to the system board, remove the main battery (see [Removing the Battery](#)) before working inside the computer.

Removing the Media Card Reader Board

1. Follow the instructions in [Before You Begin](#).
2. Remove the battery (see [Removing the Battery](#)).
3. Remove the base cover (see [Removing the Base Cover](#)).
4. Remove memory module(s) (see [Removing the Memory Module\(s\)](#)).
5. Remove the optical drive (see [Removing the Optical Drive](#)).
6. Remove the keyboard (see [Removing the Keyboard](#)).
7. Remove the palm rest (see [Removing the Palm Rest](#)).
8. Disconnect the Media Card Reader board cable from the connector on the system board and remove the cable from its routing guide.
9. Lift the Media Card Reader board out of the computer base.

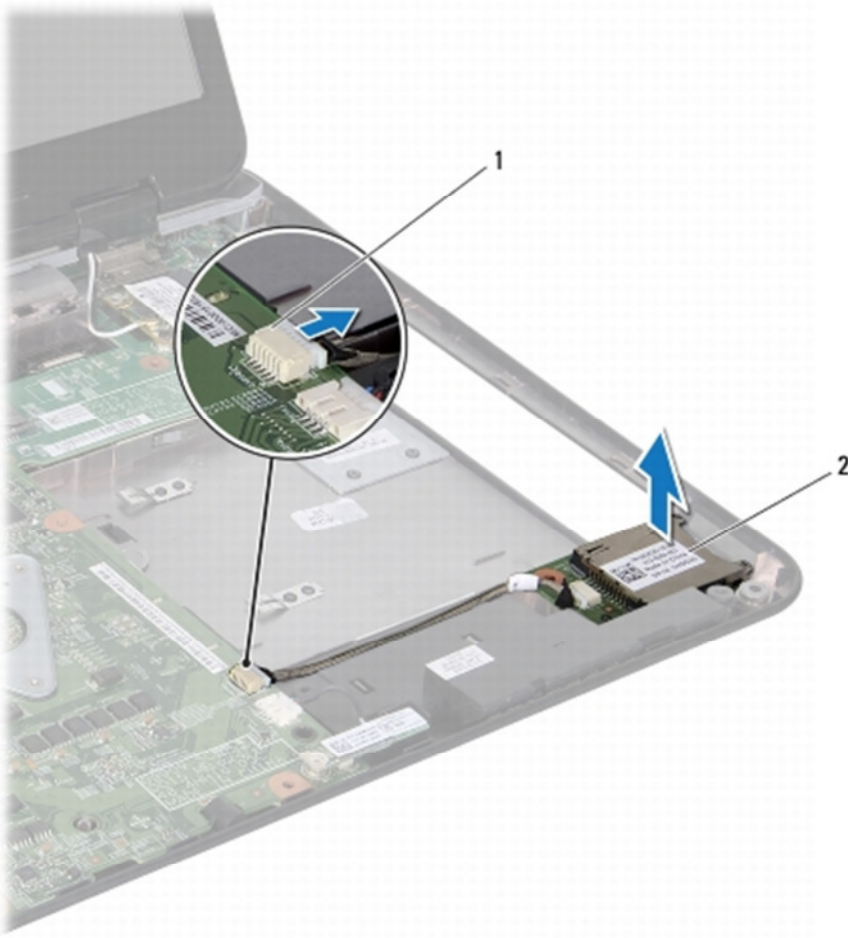

1	system board connector	2	Media Card Reader board
---	------------------------	---	-------------------------

Replacing the Media Card Reader Board

1. Follow the instructions in [Before You Begin](#).
2. Align the Media Card Reader board with the latch on the computer base and place the Media Card Reader board in position.
3. Route the Media Card Reader board cable into its routing guide.
4. Connect the Media Card Reader board cable to the connector on the system board.
5. Replace the palm rest (see [Replacing the Palm Rest](#)).
6. Replace the keyboard (see [Replacing the Keyboard](#)).
7. Replace the optical drive (see [Replacing the Optical Drive](#)).
8. Replace memory module(s) (see [Replacing the Memory Module\(s\)](#)).
9. Replace the base cover (see [Replacing the Base Cover](#)).

10. Replace the battery (see [Replacing the Battery](#)).

 **CAUTION:** Before turning on the computer, replace all screws and ensure that no stray screws remain inside the computer. Failure to do so may result in damage to the computer.

Hard Drive

Dell™ Inspiron™ N5010/M5010 Service Manual

 [Removing the Hard Drive](#)

 [Replacing the Hard Drive](#)

 **WARNING:** Before working inside your computer, read the safety information that shipped with your computer. For additional safety best practices information, see the Regulatory Compliance Homepage at www.dell.com/regulatory_compliance.

 **WARNING:** If you remove the hard drive from the computer when the drive is hot, do not touch the metal housing of the hard drive.

 **CAUTION:** Only a certified service technician should perform repairs on your computer. Damage due to servicing that is not authorized by Dell™ is not covered by your warranty.

 **CAUTION:** To prevent data loss, turn off your computer (see [Turning Off Your Computer](#)) before removing the hard drive. Do not remove the hard drive while the computer is On or in Sleep state.

 **CAUTION:** To avoid electrostatic discharge, ground yourself by using a wrist grounding strap or by periodically touching an unpainted metal surface (such as a connector on your computer).

 **CAUTION:** Hard drives are extremely fragile. Exercise care when handling the hard drive.

 **CAUTION:** To help prevent damage to the system board, remove the main battery (see [Removing the Battery](#)) before working inside the computer.

 **NOTE:** Dell does not guarantee compatibility or provide support for hard drives from sources other than Dell.

 **NOTE:** If you are installing a hard drive from a source other than Dell, you need to install an operating system, drivers, and utilities on the new hard drive (see the *Dell Technology Guide*).

Removing the Hard Drive

1. Follow the instructions in [Before You Begin](#).
2. Remove the battery (see [Removing the Battery](#)).
3. Remove the base cover (see [Removing the Base Cover](#)).
4. Remove memory module(s) (see [Removing the Memory Module\(s\)](#)).

5. Remove the optical drive (see [Removing the Optical Drive](#)).
6. Remove the keyboard (see [Removing the Keyboard](#)).
7. Remove the palm rest (see [Removing the Palm Rest](#)).

CAUTION: When the hard drive is not in the computer, store it in protective antistatic packaging (see "Protecting Against Electrostatic Discharge" in the safety instructions that shipped with your computer).

8. Remove the four screws that secure the hard-drive assembly.

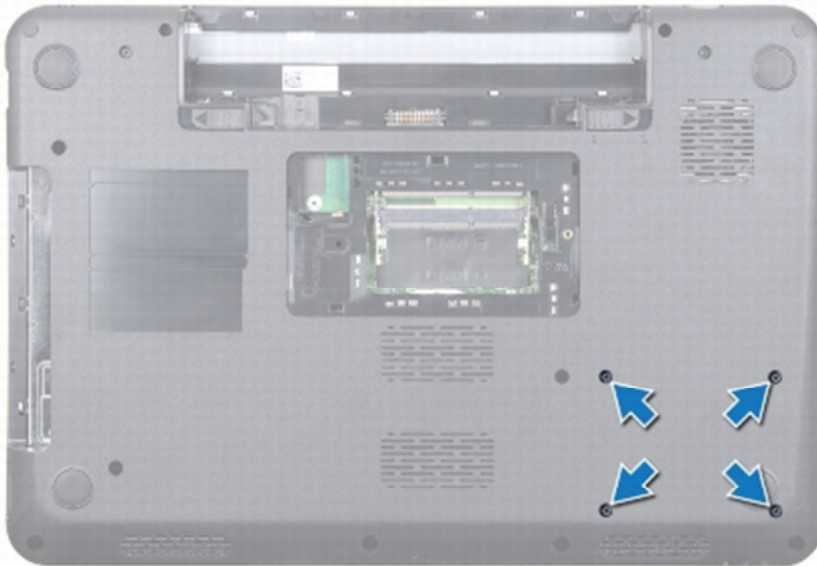

9. Turn the computer over and lift the hard-drive assembly out of the hard-drive bay to disconnect the hard-drive assembly from the connector on the system board.

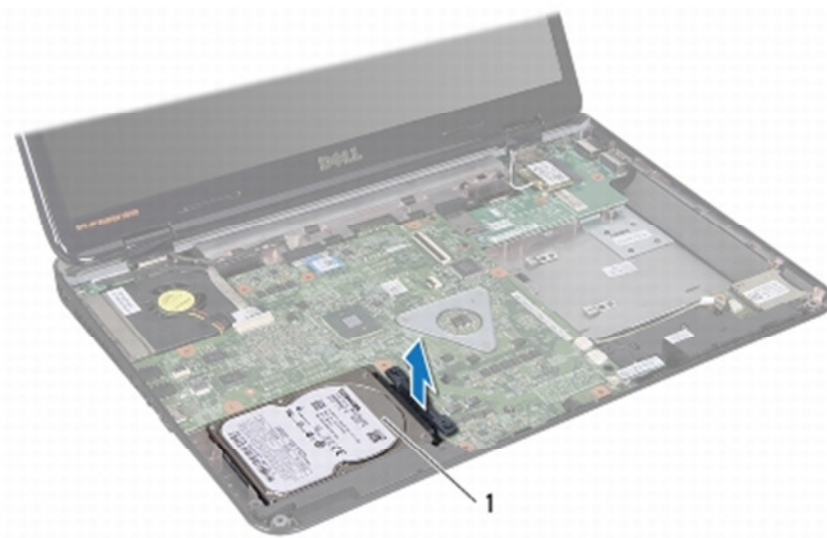

1	hard-drive assembly
---	---------------------

10. Pull the interposer to disconnect it from the hard drive.



1	hard drive	2	interposer
---	------------	---	------------

Replacing the Hard Drive

1. Follow the instructions in [Before You Begin](#).
2. Remove the new drive from its packaging.
Save the original packaging for storing or shipping the hard drive.
3. Connect the interposer to the hard drive.
4. Align the hard-drive assembly with the connector on the system board and press the hard-drive assembly into the hard-drive bay until it is fully seated.
5. Turn the computer over and replace the four screws that secure the hard-drive assembly.
6. Replace the palm rest (see [Replacing the Palm Rest](#)).
7. Replace the keyboard (see [Replacing the Keyboard](#)).
8. Replace the optical drive (see [Replacing the Optical Drive](#)).
9. Replace memory module(s) (see [Replacing the Memory Module\(s\)](#)).
10. Replace the base cover (see [Replacing the Base Cover](#)).
11. Replace the battery (see [Replacing the Battery](#)).

CAUTION: Before turning on the computer, replace all screws and ensure that no stray screws remain inside the computer. Failure to do so may result in damage to the computer.

12. Install the operating system for your computer, as needed. See "Restoring Your Operating System" in the *Setup Guide*.
13. Install the drivers and utilities for your computer, as needed. For more information, see the *Dell Technology Guide*.

Display

Dell™ Inspiron™ N5010/M5010 Service Manual

- [Display Assembly](#)
- [Display Bezel](#)
- [Display Panel](#)

 **WARNING:** Before working inside your computer, read the safety information that shipped with your computer. For additional safety best practices information, see the Regulatory Compliance Homepage at www.dell.com/regulatory_compliance.

 **CAUTION:** Only a certified service technician should perform repairs on your computer. Damage due to servicing that is not authorized by Dell™ is not covered by your warranty.

 **CAUTION:** To avoid electrostatic discharge, ground yourself by using a wrist grounding strap or by periodically touching an unpainted metal surface (such as a connector on your computer).

 **CAUTION:** To help prevent damage to the system board, remove the main battery (see [Removing the Battery](#)) before working inside the computer.

Display Assembly

Removing the Display Assembly

1. Follow the instructions in [Before You Begin](#).
2. Remove the battery (see [Removing the Battery](#)).
3. Remove the base cover (see [Removing the Base Cover](#)).
4. Remove memory module(s) (see [Removing the Memory Module\(s\)](#)).
5. Remove the optical drive (see [Removing the Optical Drive](#)).
6. Remove the keyboard (see [Removing the Keyboard](#)).
7. Remove the palm rest (see [Removing the Palm Rest](#)).
8. Turn the computer over and remove the two screws.

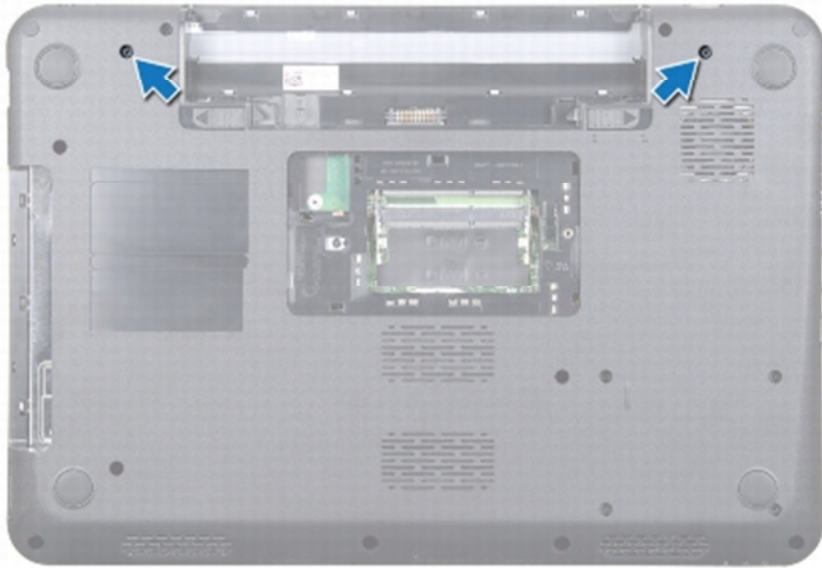

9. Disconnect the Mini-Card antenna cables from the Mini-Card.
10. Disconnect the display cable from the connector on the system board and remove it from the routing guide.
11. Remove the four screws (two on each side) that secure the display assembly to the computer base.
12. Lift and remove the display assembly out of the computer base.

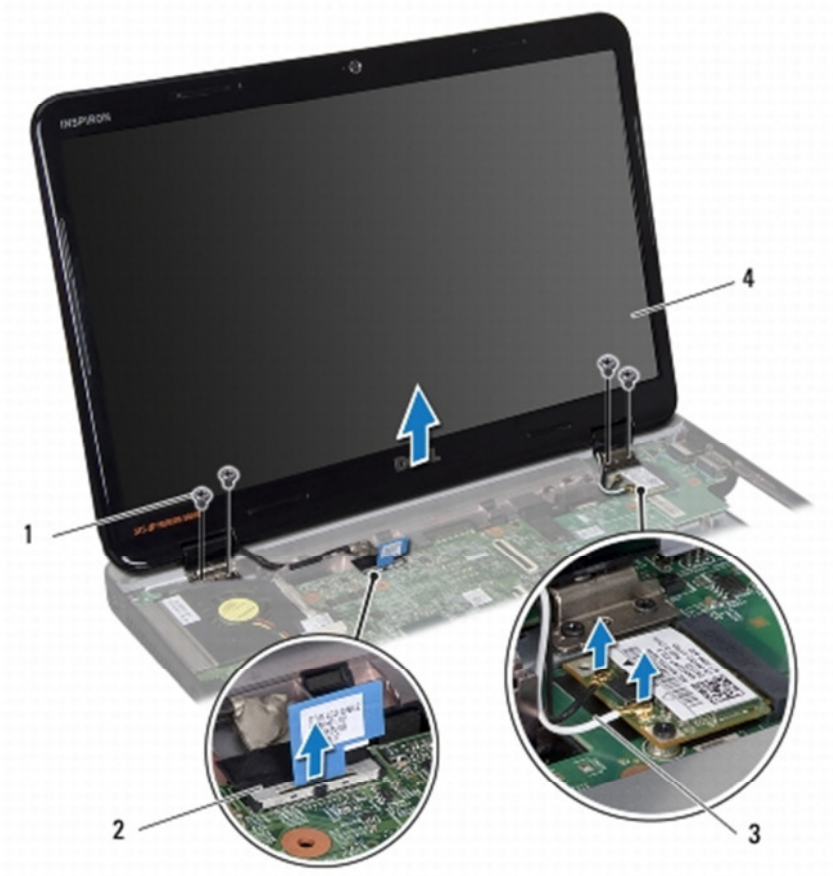

1	screws (4)	2	display cable
3	Mini-Card antenna cables	4	display assembly

Replacing the Display Assembly

1. Follow the instructions in [Before You Begin](#).
2. Place the display assembly in position and replace the four screws (two on each side) that secure the display assembly to the computer base.
3. Route the display cable into the routing guide and connect the cable to the connector on the system board.
4. Connect the Mini-Card antenna cables to the connectors on the Mini- Card.
5. Turn the computer over and replace the two screws at the bottom of the computer.
6. Replace the palm rest (see [Replacing the Palm Rest](#)).
7. Replace the keyboard (see [Replacing the Keyboard](#)).
8. Replace the optical drive (see [Replacing the Optical Drive](#)).
9. Replace memory module(s) (see [Replacing the Memory Module\(s\)](#)).
10. Replace the base cover (see [Replacing the Base Cover](#)).

11. Replace the battery (see [Replacing the Battery](#)).

CAUTION: Before turning on the computer, replace all screws and ensure that no stray screws remain inside the computer. Failure to do so may result in damage to the computer.

Display Bezel

Removing the Display Bezel

CAUTION: The display bezel is extremely fragile. Be careful when removing it to prevent damaging the bezel.

1. Follow the instructions in [Before You Begin](#).
2. Remove the display assembly (see [Removing the Display Assembly](#)).
3. Using your fingertips, carefully pry up the inside edge of the display bezel.
4. Remove the display bezel.



1 | display bezel

Replacing the Display Bezel

1. Follow the instructions in [Before You Begin](#).
2. Align the display bezel over the display panel, and gently snap into place.

3. Replace the display assembly (see [Replacing the Display Assembly](#)).
-

Display Panel

Removing the Display Panel

1. Follow the instructions in [Before You Begin](#).
2. Remove the display assembly (see [Removing the Display Assembly](#)).
3. Remove the display bezel (see [Removing the Display Bezel](#)).
4. Disconnect the camera cable from the connector on the camera module.
5. Remove the eight screws that secure the display panel to the display cover.

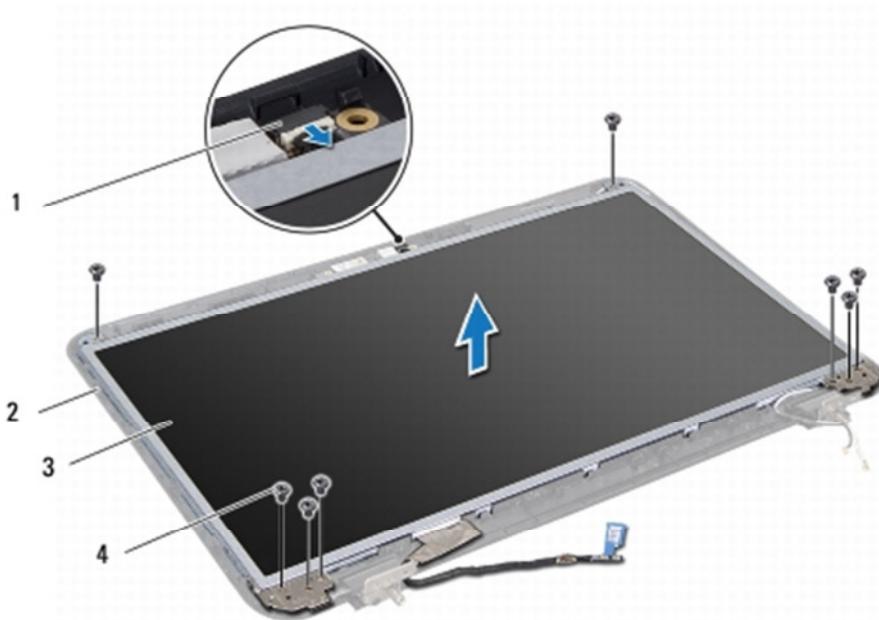

1	camera cable connector	2	display cover
3	display panel	4	screws (8)

6. Lift the display panel off the display cover.
7. Turn the display panel over and place it on a clean surface.
8. Lift the tape that secures the display cable to the display board connector and disconnect the display cable.
9. Peel off the camera cable from the back of the display panel.

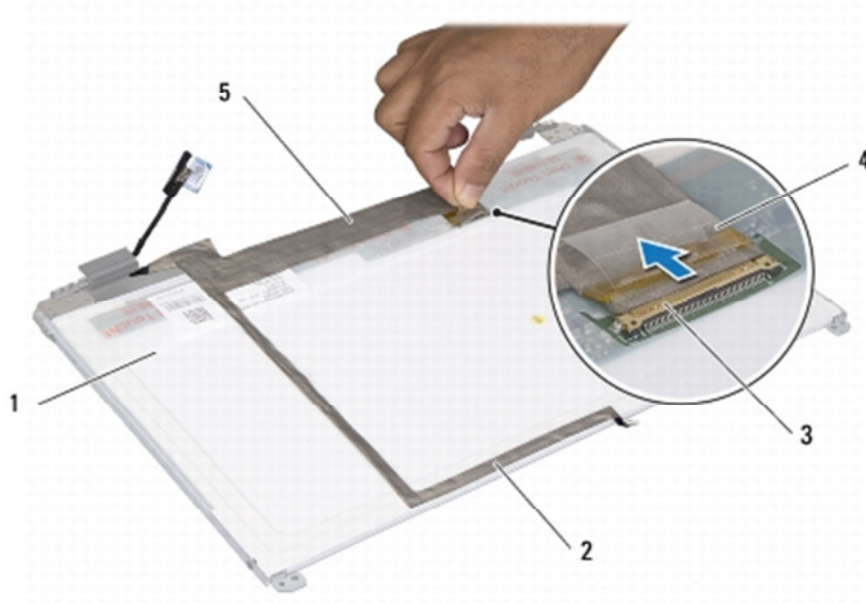

1	back of the display panel	2	camera cable
3	display board connector	4	tape
5	display cable		

10. Remove the four screws (two on each side) that secure the display panel brackets to the display panel.

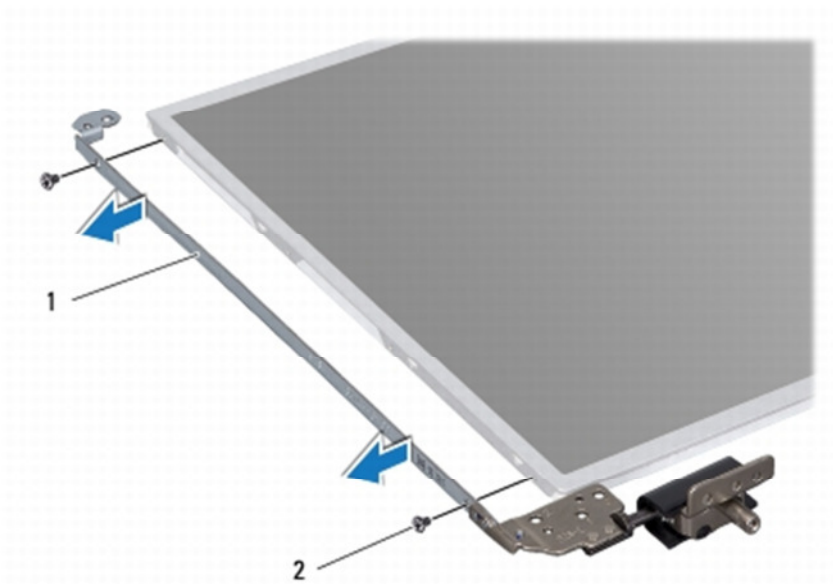

1	display panel brackets (2)	2	screws (4)
---	----------------------------	---	------------

Replacing the Display Panel

1. Follow the instructions in [Before You Begin](#).

2. Replace the four screws (two on each side) that secure the display panel brackets to the display panel.
3. Connect the display cable to the display board connector and secure it with the tape.
4. Adhere the camera cable to the back of the display panel with the tape.
5. Place the display panel on the display cover and connect the camera cable to the connector on the camera module.
6. Align the screw holes on the display panel with the screw holes on the display cover.
7. Replace the eight screws that secure the display panel to the display cover.
8. Replace the display bezel (see [Replacing the Display Bezel](#)).
9. Replace the display assembly (see [Replacing the Display Assembly](#)).

 **CAUTION:** Before turning on the computer, replace all screws and ensure that no stray screws remain inside the computer. Failure to do so may result in damage to the computer.

Camera Module

Dell™ Inspiron™ N5010/M5010 Service Manual

- [Removing the Camera Module](#)
- [Replacing the Camera Module](#)

 **WARNING:** Before working inside your computer, read the safety information that shipped with your computer. For additional safety best practices information, see the Regulatory Compliance Homepage at www.dell.com/regulatory_compliance.

 **CAUTION:** Only a certified service technician should perform repairs on your computer. Damage due to servicing that is not authorized by Dell™ is not covered by your warranty.

 **CAUTION:** To avoid electrostatic discharge, ground yourself by using a wrist grounding strap or by periodically touching an unpainted metal surface (such as a connector on your computer).

 **CAUTION:** To help prevent damage to the system board, remove the main battery (see [Removing the Battery](#)) before working inside the computer.

Removing the Camera Module

1. Follow the instructions in [Before You Begin](#).
2. Remove the battery (see [Removing the Battery](#)).

3. Remove the base cover (see [Removing the Base Cover](#)).
4. Remove memory module(s) (see [Removing the Memory Module\(s\)](#)).
5. Remove the optical drive (see [Removing the Optical Drive](#)).
6. Remove the keyboard (see [Removing the Keyboard](#)).
7. Remove the palm rest (see [Removing the Palm Rest](#)).
8. Remove the display assembly (see [Removing the Display Assembly](#)).
9. Remove the display bezel (see [Removing the Display Bezel](#)).
10. Remove the display panel (see [Removing the Display Panel](#)).
11. Peel off the metallic tape that secures the camera module to the display cover.
12. Remove the camera module from the latches that secure it.
13. Lift the camera module off the display cover.

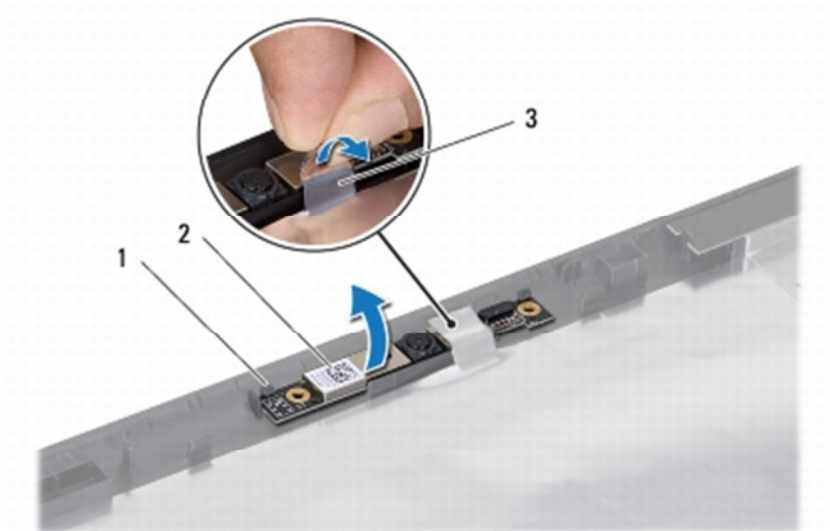

1	latches (2)	2	camera module
3	metallic tape		

Replacing the Camera Module

1. Follow the instructions in [Before You Begin](#).
2. Place the camera module on the display cover and press the camera module until it is fully seated.
3. Replace the mettalic tape that secures the camera module to the display cover.
4. Replace the display panel (see [Replacing the Display Panel](#)).

5. Replace the display bezel (see [Replacing the Display Bezel](#)).
6. Replace the display assembly (see [Replacing the Display Assembly](#)).
7. Replace the palm rest (see [Replacing the Palm Rest](#)).
8. Replace the keyboard (see [Replacing the Keyboard](#)).
9. Replace the optical drive (see [Replacing the Optical Drive](#)).
10. Replace memory module(s) (see [Replacing the Memory Module\(s\)](#)).
11. Replace the base cover (see [Replacing the Base Cover](#)).
12. Replace the battery (see [Replacing the Battery](#)).

 **CAUTION:** Before turning on the computer, replace all screws and ensure that no stray screws remain inside the computer. Failure to do so may result in damage to the computer.

Internal Module With Bluetooth® Wireless Technology

Dell™ Inspiron™ N5010/M5010 Service Manual

- [Removing the Bluetooth Module](#)
- [Replacing the Bluetooth Module](#)

 **WARNING:** Before working inside your computer, read the safety information that shipped with your computer. For additional safety best practices information, see the Regulatory Compliance Homepage at www.dell.com/regulatory_compliance.

 **CAUTION:** Only a certified service technician should perform repairs on your computer. Damage due to servicing that is not authorized by Dell™ is not covered by your warranty.

 **CAUTION:** To avoid electrostatic discharge, ground yourself by using a wrist grounding strap or by periodically touching an unpainted metal surface (such as a connector on your computer).

 **CAUTION:** To help prevent damage to the system board, remove the main battery (see [Removing the Battery](#)) before working inside the computer.

If you ordered a card with Bluetooth wireless technology with your computer, it is already installed.

Removing the Bluetooth Module

1. Follow the instructions in [Before You Begin](#).

2. Remove the battery (see [Removing the Battery](#)).
3. Remove the base cover (see [Removing the Base Cover](#)).
4. Remove memory module(s) (see [Removing the Memory Module\(s\)](#)).
5. Remove the optical drive (see [Removing the Optical Drive](#)).
6. Remove the keyboard (see [Removing the Keyboard](#)).
7. Remove the palm rest (see [Removing the Palm Rest](#)).
8. Lift the Bluetooth module to disconnect it from the connector on the system board.

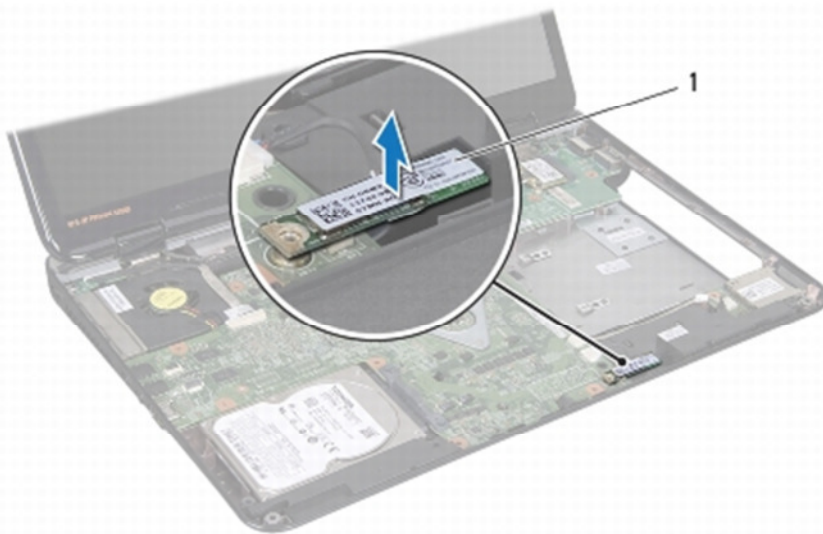

1	Bluetooth module
---	------------------

Replacing the Bluetooth Module

1. Follow the instructions in [Before You Begin](#).
2. Align the connector on the Bluetooth module with the connector on the system board and press the Bluetooth module until it is fully seated.
3. Replace the palm rest (see [Replacing the Palm Rest](#)).
4. Replace the keyboard (see [Replacing the Keyboard](#)).
5. Replace the optical drive (see [Replacing the Optical Drive](#)).
6. Replace memory module(s) (see [Replacing the Memory Module\(s\)](#)).
7. Replace the base cover (see [Replacing the Base Cover](#)).
8. Replace the battery (see [Replacing the Battery](#)).

⚠ CAUTION: Before turning on the computer, replace all screws and ensure that no

stray screws remain inside the computer. Failure to do so may result in damage to the computer.

Middle Cover

Dell™ Inspiron™ N5010/M5010 Service Manual

[Removing the Middle Cover](#)

[Replacing the Middle Cover](#)

 **WARNING:** Before working inside your computer, read the safety information that shipped with your computer. For additional safety best practices information, see the Regulatory Compliance Homepage at www.dell.com/regulatory_compliance.

 **CAUTION:** To avoid electrostatic discharge, ground yourself by using a wrist grounding strap or by periodically touching an unpainted metal surface.

 **CAUTION:** Only a certified service technician should perform repairs on your computer. Damage due to servicing that is not authorized by Dell™ is not covered by your warranty.

 **CAUTION:** To help prevent damage to the system board, remove the main battery (see [Removing the Battery](#)) before working inside the computer.

Removing the Middle Cover

1. Follow the instructions in [Before You Begin](#).
2. Remove the battery (see [Removing the Battery](#)).
3. Remove the base cover (see [Removing the Base Cover](#)).
4. Remove memory module(s) (see [Removing the Memory Module\(s\)](#)).
5. Remove the optical drive (see [Removing the Optical Drive](#)).
6. Remove the keyboard (see [Removing the Keyboard](#)).
7. Remove the palm rest (see [Removing the Palm Rest](#)).
8. Remove the Mini-Card (see [Removing the Mini-Card](#)).
9. Remove the display assembly (see [Removing the Display Assembly](#)).
10. Turn the computer over and remove the two rubber caps that cover the screws.



11. Remove the four screws that secure the middle cover to the computer base.

12. Release the tabs that secure the middle cover to the computer base.

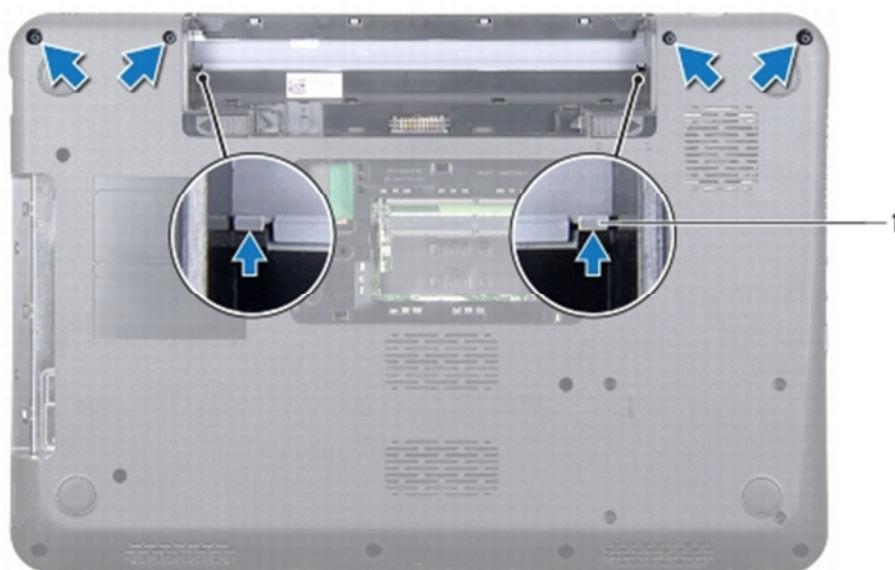

1	tabs (2)
---	----------

13. Turn the computer over and lift the middle cover off the computer base.



1	middle cover
---	--------------

Replacing the Middle Cover





1. Align the tabs beneath the middle cover with the slots on the computer base and snap the middle cover into place.
2. Turn the computer over and replace the four screws that secure the middle cover to the computer base.
3. Replace the display assembly (see [Replacing the Display Assembly](#)).
4. Replace the Mini-Card (see [Replacing the Mini-Card](#)).
5. Replace the palm rest (see [Replacing the Palm Rest](#)).
6. Replace the keyboard (see [Replacing the Keyboard](#)).
7. Replace the optical drive (see [Replacing the Optical Drive](#)).
8. Replace memory module(s) (see [Replacing the Memory Module\(s\)](#)).
9. Replace the base cover (see [Replacing the Base Cover](#)).
10. Replace the battery (see [Replacing the Battery](#)).

CAUTION: Before turning on the computer, replace all screws and ensure that no stray screws remain inside the computer. Failure to do so may result in damage to the computer.

VGA Connector Board

Dell™ Inspiron™ N5010/M5010 Service Manual

- [Removing the VGA Connector Board](#)
- [Replacing the VGA Connector Board](#)

-  **WARNING:** Before working inside your computer, read the safety information that shipped with your computer. For additional safety best practices information, see the Regulatory Compliance Homepage at www.dell.com/regulatory_compliance.
-  **CAUTION:** Only a certified service technician should perform repairs on your computer. Damage due to servicing that is not authorized by Dell™ is not covered by your warranty.
-  **CAUTION:** To avoid electrostatic discharge, ground yourself by using a wrist grounding strap or by periodically touching an unpainted metal surface (such as a connector on your computer).
-  **CAUTION:** To help prevent damage to the system board, remove the main battery (see [Removing the Battery](#)) before working inside the computer.
-

Removing the VGA Connector Board

1. Follow the instructions in [Before You Begin](#).
2. Remove the battery (see [Removing the Battery](#)).
3. Remove the base cover (see [Removing the Base Cover](#)).
4. Remove memory module(s) (see [Removing the Memory Module\(s\)](#)).
5. Remove the optical drive (see [Removing the Optical Drive](#)).
6. Remove the keyboard (see [Removing the Keyboard](#)).
7. Remove the palm rest (see [Removing the Palm Rest](#)).
8. Remove the display assembly (see [Removing the Display Assembly](#)).
9. Remove the middle cover (see [Removing the Middle Cover](#)).
10. Disconnect the VGA connector board cable from the connector on the system board and remove it from the routing guide.
11. Remove the VGA connector board from the tab on the computer base.
12. Lift the VGA connector board along with the cable off the computer base.

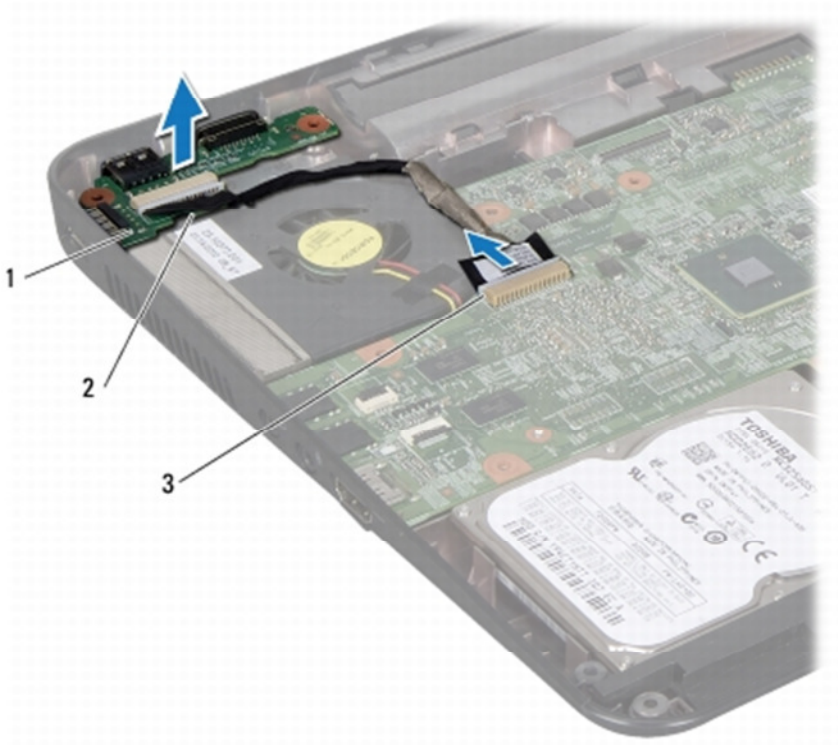

1	VGA connector board	2	tab
3	system board connector		

Replacing the VGA Connector Board

1. Follow the instructions in [Before You Begin](#).
2. Place the VGA connector board along with the cable on the computer base and press the VGA connector board until it is seated fully.
3. Route the VGA connector board cable into the routing guide and connect the cable to the connector on the system board.
4. Replace the middle cover (see [Replacing the Middle Cover](#)).
5. Replace the display assembly (see [Replacing the Display Assembly](#)).
6. Replace the palm rest (see [Replacing the Palm Rest](#)).
7. Replace the keyboard (see [Replacing the Keyboard](#)).
8. Replace the optical drive (see [Replacing the Optical Drive](#)).
9. Replace memory module(s) (see [Replacing the Memory Module\(s\)](#)).
10. Replace the base cover (see [Replacing the Base Cover](#)).
11. Replace the battery (see [Replacing the Battery](#)).

 **CAUTION:** Before turning on the computer, replace all screws and ensure that no stray screws remain inside the computer. Failure to do so may result in damage to the computer.

System Board

Dell™ Inspiron™ N5010/M5010 Service Manual

- [Removing the System Board](#)
- [Replacing the System Board](#)
- [Entering the Service Tag in the BIOS](#)

 **WARNING:** Before working inside your computer, read the safety information that shipped with your computer. For additional safety best practices information, see the Regulatory Compliance Homepage at www.dell.com/regulatory_compliance.

 **CAUTION:** Only a certified service technician should perform repairs on your computer. Damage due to servicing that is not authorized by Dell™ is not covered by your warranty.

 **CAUTION:** To avoid electrostatic discharge, ground yourself by using a wrist grounding strap or by periodically touching an unpainted metal surface (such as a connector on your computer).

 **CAUTION:** To help prevent damage to the system board, remove the main battery (see [Removing the Battery](#)) before working inside the computer.

Removing the System Board

1. Follow the instructions in [Before You Begin](#).
2. Remove the battery (see [Removing the Battery](#)).
3. Remove the base cover (see [Removing the Base Cover](#)).
4. Remove memory module(s) (see [Removing the Memory Module\(s\)](#)).
5. Remove the optical drive (see [Removing the Optical Drive](#)).
6. Remove the keyboard (see [Removing the Keyboard](#)).
7. Remove the palm rest (see [Removing the Palm Rest](#)).
8. Follow the instructions in [step 8](#) and [step 9](#) in [Removing the Hard Drive](#).
9. Remove the Mini-Card (see [Removing the Mini-Card](#)).
10. Remove the Bluetooth module (see [Removing the Bluetooth Module](#)).
11. Disconnect the display cable, VGA connector board cable, speaker cable, and Media Card Reader board cable from the connectors on the system board.
12. Remove the two screws that secure the system board assembly to the computer base.

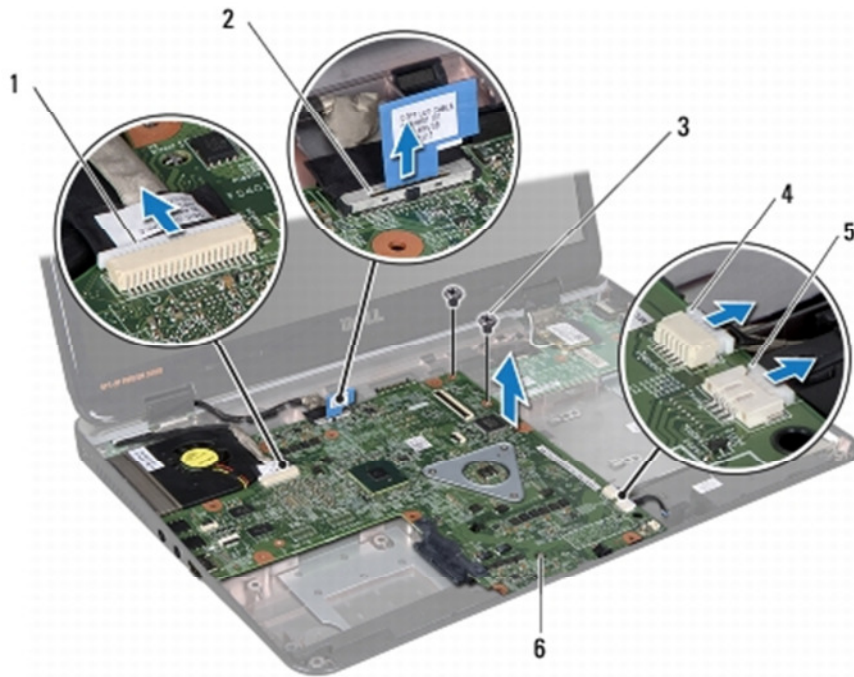

1	VGA connector board cable connector	2	display cable connector
3	screws (2)	4	Media Card Reader board cable connector
5	speaker cable connector	6	system board assembly

13. Lift the system board assembly to disconnect connector on the system board from the connector on the I/O board and lift the system board assembly off the computer base.
14. Turn the system board assembly over.
15. Remove the coin-cell battery (see [Removing the Coin-Cell Battery](#)).
16. Remove the processor heat sink (see [Removing the Processor Heat Sink](#)).
17. Remove the processor module (see [Removing the Processor Module](#)).

Replacing the System Board

1. Follow the instructions in [Before You Begin](#).
2. Replace the processor module (see [Replacing the Processor Module](#)).
3. Replace the processor heat sink (see [Replacing the Processor Heat Sink](#)).
4. Replace the coin-cell battery (see [Replacing the Coin-Cell Battery](#)).
5. Turn the system board assembly over.
6. Align the connectors on the system board with the slots on the computer base.

7. Gently press the system board to connect the connector on the system board to the connector on the I/O board.
8. Replace the two screws that secure the system board assembly to the computer base.
9. Connect the display cable, VGA connector board cable, speaker cable, and Media Card Reader board cable to the connectors on the system board.
10. Replace the Bluetooth module (see [Replacing the Bluetooth Module](#)).
11. Replace the Mini-Card (see [Replacing the Mini-Card](#)).
12. Follow the instructions in [step 4](#) and [step 5](#) in [Replacing the Hard Drive](#).
13. Replace the palm rest (see [Replacing the Palm Rest](#)).
14. Replace the keyboard (see [Replacing the Keyboard](#)).
15. Replace the optical drive (see [Replacing the Optical Drive](#)).
16. Replace memory module(s) (see [Replacing the Memory Module\(s\)](#)).
17. Replace the base cover (see [Replacing the Base Cover](#)).
18. Replace the battery (see [Replacing the Battery](#)).



CAUTION: Before turning on the computer, replace all screws and ensure that no stray screws remain inside the computer. Failure to do so may result in damage to the computer.

19. Turn on the computer.



NOTE: After you have replaced the system board, enter the computer Service Tag in the BIOS of the replacement system board.

20. Enter the service tag (see [Entering the Service Tag in the BIOS](#)).

Entering the Service Tag in the BIOS

1. Ensure that the AC adapter is plugged in and that the main battery is installed properly.
2. Turn on the computer.
3. Press <F2> during POST to enter the system setup program.
4. Navigate to the security tab and enter the service tag in the **Set Service Tag** field.

Coin-Cell Battery

Dell™ Inspiron™ N5010/M5010 Service Manual

- [Removing the Coin-Cell Battery](#)
- [Replacing the Coin-Cell Battery](#)

WARNING: Before working inside your computer, read the safety information that shipped with your computer. For additional safety best practices information, see the Regulatory Compliance Homepage at www.dell.com/regulatory_compliance.

CAUTION: Only a certified service technician should perform repairs on your computer. Damage due to servicing that is not authorized by Dell™ is not covered by your warranty.

CAUTION: To avoid electrostatic discharge, ground yourself by using a wrist grounding strap or by periodically touching an unpainted metal surface (such as a connector on your computer).

CAUTION: To help prevent damage to the system board, remove the main battery (see [Removing the Battery](#)) before working inside the computer.

Removing the Coin-Cell Battery

1. Follow the instructions in [Before You Begin](#).
2. Remove the battery (see [Removing the Battery](#)).
3. Follow the instructions from [step 3](#) to [step 14](#) in [Removing the System Board](#).
4. Using a plastic scribe, pry the coin-cell battery from the slot on the system board.



1	plastic scribe	2	coin-cell battery
---	----------------	---	-------------------

Replacing the Coin-Cell Battery

1. Follow the instructions in [Before You Begin](#).
2. Hold the coin-cell battery with the positive side facing up.
3. Slide the coin-cell battery into the slot and gently press until it snaps into place.
4. Follow the instructions from [step 5](#) to [step 17](#) in [Replacing the System Board](#).
5. Replace the battery (see [Replacing the Battery](#)).

 **CAUTION:** Before turning on the computer, replace all screws and ensure that no stray screws remain inside the computer. Failure to do so may result in damage to the computer.

[Back to Contents Page](#)

Processor Heat Sink

Dell™ Inspiron™ N5010/M5010 Service Manual

 [Removing the Processor Heat Sink](#)

 [Replacing the Processor Heat Sink](#)

 **WARNING:** Before working inside your computer, read the safety information that shipped with your computer. For additional safety best practices information, see the Regulatory Compliance Homepage at www.dell.com/regulatory_compliance.

 **WARNING:** If you remove the processor heat sink from the computer when the heat sink is hot, do not touch the metal housing of the processor heat sink.

 **CAUTION:** Only a certified service technician should perform repairs on your computer. Damage due to servicing that is not authorized by Dell™ is not covered by your warranty.

 **CAUTION:** To avoid electrostatic discharge, ground yourself by using a wrist grounding strap or by periodically touching an unpainted metal surface (such as a connector on your computer).

 **CAUTION:** To help prevent damage to the system board, remove the main battery (see [Removing the Battery](#)) before working inside the computer.

Removing the Processor Heat Sink

1. Follow the instructions in [Before You Begin](#).
2. Remove the battery (see [Removing the Battery](#)).
3. Follow the instructions from [step 3](#) to [step 14](#) in [Removing the System Board](#).
4. Disconnect the fan cable from the connector on the system board.
5. In sequential order (indicated on the processor heat sink), loosen the four captive screws that secure the processor heat sink to the system board.

 **NOTE:** The appearance and number of screws on the processor heat sink may vary based on the your computer model.

6. Lift the processor heat sink off the system board.

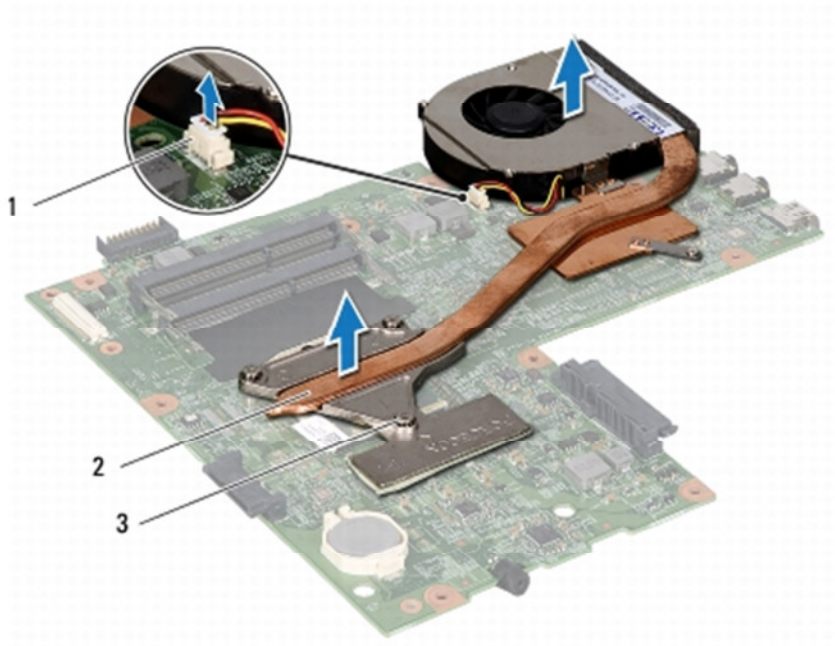

1	fan cable connector	2	processor heat sink
3	captive screws (4)		

Replacing the Processor Heat Sink

NOTE: This procedure assumes that you have already removed the processor heat sink and are ready to replace it.

1. Follow the instructions in [Before You Begin](#).
2. Place the processor heat sink on the system board.
3. Align the four captive screws on the processor heat sink with the screw holes on the system board and tighten the screws in sequential order (indicated on the processor heat sink).

NOTE: The appearance and number of screws on the processor heat sink may vary based on the your computer model.

4. Connect the fan cable to the connector on the system board.
5. Follow the instructions from [step 5](#) to [step 17](#) in [Replacing the System Board](#).
6. Replace the battery (see [Replacing the Battery](#)).

CAUTION: Before turning on the computer, replace all screws and ensure that no stray screws remain inside the computer. Failure to do so may result in damage to the computer.

Processor Module

Dell™ Inspiron™ N5010/M5010 Service Manual

- [Removing the Processor Module](#)
- [Replacing the Processor Module](#)

 **WARNING:** Before working inside your computer, read the safety information that shipped with your computer. For additional safety best practices information, see the Regulatory Compliance Homepage at www.dell.com/regulatory_compliance.

 **CAUTION:** Only a certified service technician should perform repairs on your computer. Damage due to servicing that is not authorized by Dell™ is not covered by your warranty.

 **CAUTION:** To avoid electrostatic discharge, ground yourself by using a wrist grounding strap or by periodically touching an unpainted metal surface (such as a connector on your computer).

 **CAUTION:** To help prevent damage to the system board, remove the main battery (see [Removing the Battery](#)) before working inside the computer.

Removing the Processor Module

1. Follow the instructions in [Before You Begin](#).
2. Remove the battery (see [Removing the Battery](#)).
3. Follow the instructions from [step 3](#) to [step 14](#) in [Removing the System Board](#).
4. Remove the processor heat sink (see [Removing the Processor Heat Sink](#)).

 **CAUTION:** To prevent intermittent contact between the ZIF-socket cam screw and the processor when removing or replacing the processor, press to apply slight pressure to the center of the processor while turning the cam screw.

 **CAUTION:** To avoid damage to the processor, hold the screwdriver so that it is perpendicular to the processor when turning the cam screw.

5. To loosen the ZIF socket, use a small, flat-blade screwdriver and rotate the ZIF-socket cam screw counterclockwise until it comes to the cam stop.

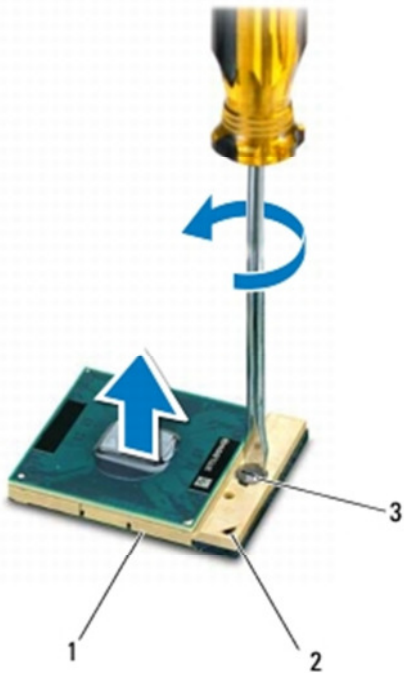

1	ZIF socket	2	pin-1 corner
3	ZIF-socket cam screw		

- ⚠ **CAUTION:** To ensure maximum cooling for the processor, do not touch the heat transfer areas on the processor thermal-cooling assembly. The oils in your skin can reduce the heat transfer capability of the thermal pads.
- ⚠ **CAUTION:** When removing the processor module, pull the module straight up. Be careful not to bend the pins on the processor module.

6. Lift the processor module from the ZIF socket.

Replacing the Processor Module

 **NOTE:** If a new processor is installed, you will receive a new thermal-cooling assembly, which will include an affixed thermal pad, or you will receive a new thermal pad along with documentation to illustrate proper installation.

1. Follow the instructions in [Before You Begin](#).
2. Align the pin-1 corner of the processor module with the pin-1 corner of the ZIF socket, then insert the processor module.

 **NOTE:** The pin-1 corner of the processor module has a triangle that aligns with the triangle on the pin-1 corner of the ZIF socket.

When the processor module is properly seated, all four corners are aligned at the same height. If one or more corners of the module are higher than the others, the module is not seated properly.

 **CAUTION:** To avoid damage to the processor module, hold the screwdriver perpendicular to the processor module when turning the cam screw.

3. Tighten the ZIF socket by turning the cam screw clockwise to secure the processor module to the system board.
4. Replace the processor heat sink (see [Replacing the Processor Heat Sink](#)).
5. Follow the instructions from [step 5](#) to [step 17](#) in [Replacing the System Board](#).
6. Replace the battery (see [Replacing the Battery](#)).

 **CAUTION:** Before turning on the computer, replace all screws and ensure that no stray screws remain inside the computer. Failure to do so may result in damage to the computer.

Speakers

Dell™ Inspiron™ N5010/M5010 Service Manual

- [Removing the Speakers](#)
- [Replacing the Speakers](#)

 **WARNING:** Before working inside your computer, read the safety information that shipped with your computer. For additional safety best practices information, see the Regulatory Compliance Homepage at www.dell.com/regulatory_compliance.

 **CAUTION:** Only a certified service technician should perform repairs on your computer. Damage due to servicing that is not authorized by Dell™ is not covered by your warranty.

 **CAUTION:** To avoid electrostatic discharge, ground yourself by using a wrist grounding strap or by periodically touching an unpainted metal surface (such as a connector on your computer).

 **CAUTION:** To help prevent damage to the system board, remove the main battery (see [Removing the Battery](#)) before working inside the computer.

Removing the Speakers

1. Follow the instructions in [Before You Begin](#).
2. Remove the battery (see [Removing the Battery](#)).
3. Follow the instructions from [step 3](#) to [step 13](#) in [Removing the System Board](#).
4. Remove the speakers from the latches that secure the speakers to the computer base.

5. Make note of the speaker cable routing and lift the speakers along with the cable, off the computer base.

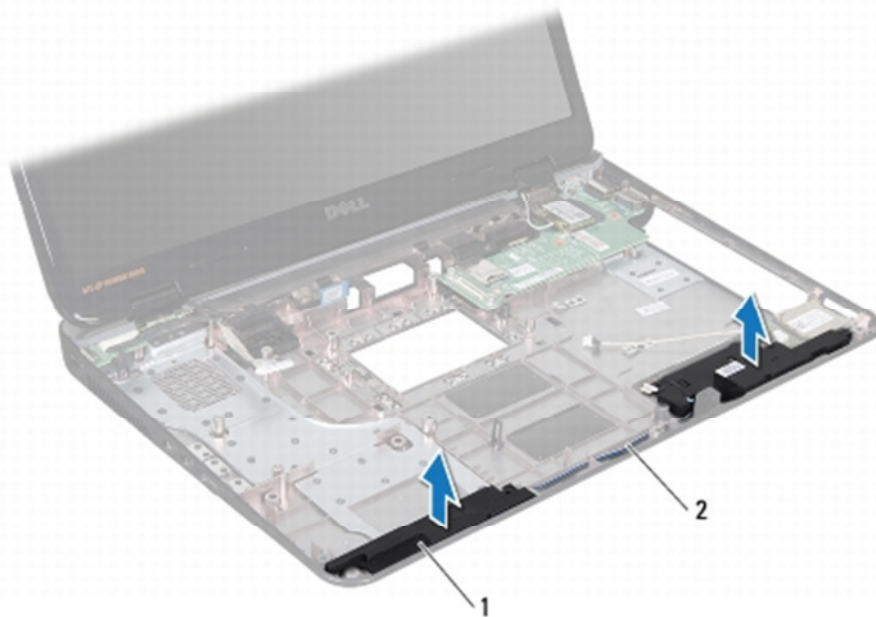

1	speakers (2)	2	speaker cable
---	--------------	---	---------------

Replacing the Speakers

1. Follow the instructions in [Before You Begin](#).
2. Align the speakers with the latches on the computer base and place the speakers in place.
3. Route the speaker cable into the routing guides.
4. Follow the instructions from [step 6](#) to [step 17](#) in [Replacing the System Board](#).
5. Replace the battery (see [Replacing the Battery](#)).

CAUTION: Before turning on the computer, replace all screws and ensure that no stray screws remain inside the computer. Failure to do so may result in damage to the computer.

I/O Board

Dell™ Inspiron™ N5010/M5010 Service Manual

- [Removing the I/O Board](#)
- [Replacing the I/O Board](#)

WARNING: Before working inside your computer, read the safety information that shipped with your computer. For additional safety best practices information, see the Regulatory Compliance Homepage at www.dell.com/regulatory_compliance.

- CAUTION:** Only a certified service technician should perform repairs on your computer. Damage due to servicing that is not authorized by Dell™ is not covered by your warranty.
 - CAUTION:** To avoid electrostatic discharge, ground yourself by using a wrist grounding strap or by periodically touching an unpainted metal surface (such as a connector on your computer).
 - CAUTION:** To help prevent damage to the system board, remove the main battery (see [Removing the Battery](#)) before working inside the computer.
-

Removing the I/O Board

1. Follow the instructions in [Before You Begin](#).
2. Remove the battery (see [Removing the Battery](#)).
3. Follow the instructions from [step 3](#) to [step 13](#) in [Removing the System Board](#).
4. Remove the middle cover (see [Removing the Middle Cover](#)).
5. Remove the I/O board from the latch on the computer base.
6. Lift the I/O board off the computer base.

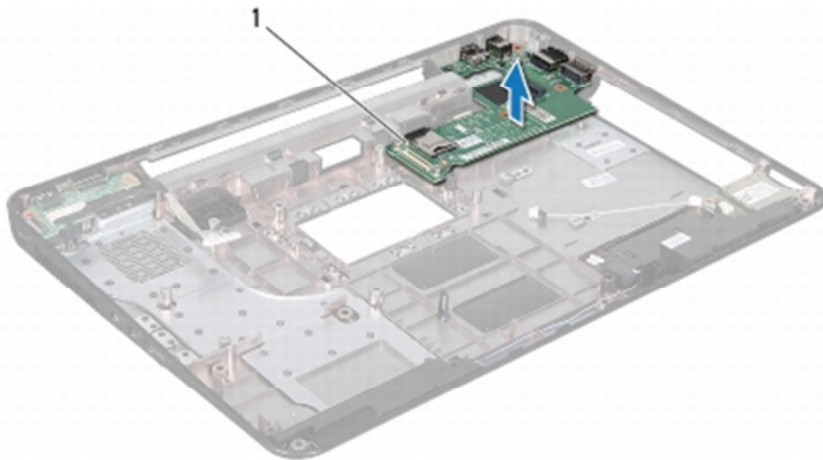

1	I/O board
---	-----------

Replacing the I/O Board

1. Follow the instructions in [Before You Begin](#).
2. Align the connectors on the I/O board with the slots on the computer base and press the I/O board until it is seated fully.
3. Replace the middle cover (see [Replacing the Middle Cover](#)).
4. Follow the instructions from [step 6](#) to [step 17](#) in [Replacing the System Board](#).

5. Replace the battery (see [Replacing the Battery](#)).

 **CAUTION:** Before turning on the computer, replace all screws and ensure that no stray screws remain inside the computer. Failure to do so may result in damage to the computer.

Flashing the BIOS

Dell™ Inspiron™ N5010/M5010 Service Manual

1. Turn on the computer.
2. Go to **support.dell.com/support/downloads**.
3. Locate the BIOS update file for your computer:

 **NOTE:** The Service Tag for your computer is located on a label at the bottom of the computer.

If you have your computer's Service Tag:

- a. Click **Enter a Service Tag**.
- b. Enter your computer's Service Tag in the **Enter a service tag:** field, click **Go**, and proceed to [step 4](#).

If you do not have your computer's Service Tag:

- a. Select the type of product in the **Select Your Product Family** list.
- b. Select the product brand in the **Select Your Product Line** list.
- c. Select the product model number in the **Select Your Product Model** list.

 **NOTE:** If you have selected a different model and want to start over again, click **Start Over** on the top right of the menu.

- d. Click **Confirm**.
4. A list of results appear on the screen. Click **BIOS**.
 5. Click **Download Now** to download the latest BIOS file. The **File Download** window appears.
 6. Click **Save** to save the file on your desktop. The file downloads to your desktop.
 7. Click **Close** if the **Download Complete** window appears. The file icon appears on your desktop and is titled the same as the downloaded BIOS update file.
 8. Double-click the file icon on the desktop and follow the instructions on the screen.
-