

# Acer Aspire 1700 Series

## Service Guide

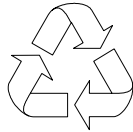

100% Recycled Paper

PART NO.: VD.A08V7.001

PRINTED IN TAIWAN

---

## Revision History

Please refer to the table below for the updates made on TravelMate 800 service guide.

Date	Chapter	Updates

---

## Conventions

The following conventions are used in this manual:

<b>SCREEN MESSAGES</b>	Denotes actual messages that appear on screen.
<b>NOTE</b>	Gives bits and pieces of additional information related to the current topic.
<b>WARNING</b>	Alerts you to any damage that might result from doing or not doing specific actions.
<b>CAUTION</b>	Gives precautionary measures to avoid possible hardware or software problems.
<b>IMPORTANT</b>	Reminds you to do specific actions relevant to the accomplishment of procedures.

---

## Preface

Before using this information and the product it supports, please read the following general information.

1. This Service Guide provides you with all technical information relating to the BASIC CONFIGURATION decided for Acer's "global" product offering. To better fit local market requirements and enhance product competitiveness, your regional office MAY have decided to extend the functionality of a machine (e.g. add-on card, modem, or extra memory capability). These LOCALIZED FEATURES will NOT be covered in this generic service guide. In such cases, please contact your regional offices or the responsible personnel/channel to provide you with further technical details.
2. Please note WHEN ORDERING FRU PARTS, that you should check the most up-to-date information available on your regional web or channel. If, for whatever reason, a part number change is made, it will not be noted in the printed Service Guide. For ACER-AUTHORIZED SERVICE PROVIDERS, your Acer office may have a DIFFERENT part number code to those given in the FRU list of this printed Service Guide. You MUST use the list provided by your regional Acer office to order FRU parts for repair and service of customer machines.



<b>Chapter 1</b>	<b>System Specifications</b>	<b>1</b>
	Overview .....	1
	Features .....	2
	Outlook .....	3
	Main Board Layout .....	9
	Hardware Specifications and Configurations .....	10
	Power Management Function (ACPI support function) .....	18
	BIOS Setup Utility .....	19
<b>Chapter 2</b>	<b>System Utilities 19</b>	
	Navigating the BIOS Utility .....	20
	Info. ....	21
	Main .....	22
	System Devices .....	24
	Security .....	25
	Boot .....	28
	Exit .....	29
<b>Chapter 3</b>	<b>Machine Disassembly and Replacement</b>	<b>31</b>
	General Information .....	32
	Before You Begin .....	32
	Disassembly Procedure Flowchart .....	33
	Disassembling .....	36
	Remove the battery .....	36
	Remove the HDD module .....	36
	Remove the combo drive .....	36
	Remove the thermal module .....	37
	Remove CPU .....	37
	Remove the memory .....	37
	Remove VGA card .....	37
	Detach the wireless card .....	38
	Remove moden card .....	38
	Remove the inverter cover .....	38
	Detach the upper system cover .....	39
	Remove the LCD module .....	39
	Remove the LCD panel .....	40
	Remove the inverter board .....	40
	Remove the mylars .....	42
	Remove the wireless module .....	42
	Remove the side bracket 42	
	Remove the LED cable attached on the LCD outer shield. ....	43
	Remove the subwoofer .....	43
	Release the MDC cable. ....	44
	Disconnect the cable to the modem header. ....	44
	Remove the keyboard .....	44
	Remove the LED board .....	44
	Detach the front panel .....	45
	Remove the Audio DJ board .....	45
	Remove the touch pad .....	46
	Remove the touch pad board .....	47
	Remove the lid switch cable .....	47
	Remove the floppy drive .....	47
	Remove the speaker set .....	48
	Remove the mainboard .....	48

# Table of Contents

Remove the system fan	49
FDD Module	50
HDD Module	50
Combo Module	51
General Information	54
Before You Begin	54
Re-assembly 55	
Place the system fan	55
Re-assembling the mainboard	55
Place the speaker set back to position	56
Place the floppy module back to position	57
Place the touch pad back to position	57
Reconnect the Audio DJ board	58
Place the system cover back to position	58
Reconnect the LED cable	59
Place the keyboard back to position	59
Place the MDC cable back to position	60
Reconnect the sub-woofer	60
Place the LED cable back to position	60
Place the side mount back to position.	61
Place the wireless antenna back to position	61
Reattach the LCD cable	62
Place the inverter board back to position	62
Re-assembling the LCD module	63
Place the system cover and hinge back to position	64
Place the inverter cover back to position	64
Reconnect the cable to the MDC card and wireless card	64
Place the VGA card back to position.	65
Insert the memory	65
Place the CPU back	66
Place the thermal module back to position	66
Place the floppy back to position	66
Reconnect the HDD power and coaxial cable.	66
Place the battery or dummy battery back to position.	67
Place the bottom shield back to position.	67
FDD Module	68
HDD Module	68
Combo Module	69
<b>Chapter 4 Troubleshooting</b>	<b>71</b>
System Check Procedures	72
External Diskette Drive Check	72
External CD-ROM Drive Check	72
Keyboard or Auxiliary Input Device Check	72
Memory check	73
Power System Check	73
Touchpad check	74
Power-On Self-Test (POST) Error Message	75
Index of Error Messages	76
Index of Symptom-to-FRU Error Message	78
Intermittent Problems	82
Undetermined Problems	83
Aspire 1700 Jumpers and Connectors	85

# Table of Contents

<b>Chapter 5</b>	<b>Jumper and Connector Locations</b>	<b>85</b>
	Top view .....	85
	Connector Description .....	86
	Bottom View .....	87
	Connector Description .....	88
<b>Chapter 6</b>	<b>FRU List</b>	<b>89</b>
	Exploded Diagram .....	89
	The System .....	89
	LCD 17" ASSY .....	90
	FDD ASSY .....	90
	HDD ASSY .....	91
	ODD ASSY .....	91
	FRU List .....	93
<b>Appendix A</b>	<b>Model Definition and Configuration</b>	<b>100</b>
	Aspire 1700 Series .....	100
	Main Features .....	101
<b>Appendix B</b>	<b>Test Compatible Components</b>	<b>103</b>
	Microsoft® Windows® XP Environment Test .....	104
<b>Appendix C</b>	<b>Online Support Information</b>	<b>109</b>



# ***Table of Contents***

# System Specifications

---

## Overview

Aspire 1700 is designed to be a mobile desktop. It can support Intel Pentium 4 Northwood as well as Intel Celeron with front side bus 400MHz or 533MHz. The LCD panel ranges from 15" to 17" and the capacity is built to be below 6 liters.

---

# Features

## Performance

- Intel Pentium 4 Northwood 1.8~3.06 GHz/Celeron processor
- L2 cache 512k (Northwood), 128K (Celeron)
- SiS M650 with SiS 962, support 400/533MHz Bus, HTT support.
- 20GB or higher capacity Desktop 5400rpm, 7200rpm HDD
- Microsoft XP OS
- Optional 6-in-1 Multimedia memory card module.

## Multimedia

- CD-ROM
- DVD-ROM
- DVD/CD-RW combo
- Audio input and output jacks
- Optional 6-in-1 Multimedia memory card module
- Hardware 3D graphic engine
- Two stereo speakers + One sub-woofer
- 15" Desktop XGA and 17" Desktop SXGA.

## Connectivity

- Modem: Software Modem V9.0/V9.2 56Kbps (MDC)
- 10/100 LAN
- Optional Mini-PCI 802.11b/802.11a+b/bluetooth
- One switch for on/off of wireless
- Keyboard and touchpad with 4 way scroll buttons
- 4 universal serial bus (USB) ports.

## Human-centric design and ergonomics

- Rugged and space saving
- Full size desktop keyboard

*justmanuals.com*

---

# Outlook

## Opened Front View



Label	Description
1	Display
2	Power button
3	Keyboard
4	Touchpad
5	Click button & scroll key
6	Audio DJ controls and indicator
7	Palm rest
8	Launch keys
9	Status indicators

---

## Closed Front view



#	Item	Description
1	Speakers	Left and right speakers deliver stereo audio output
2	Wireless communication indicator	Lights when the Wireless LAN capability is enabled.
3	Power indicator	Lights when the computer is on.



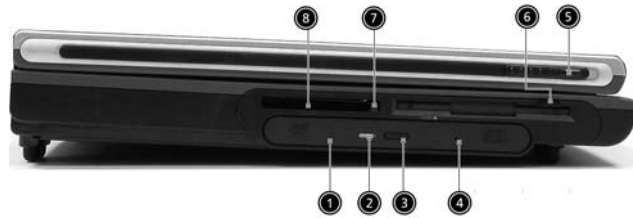

## Left view



#	Item	Description
1	Optical drive	Depending on your model, the optical drive is one of the following: CD-ROM drive for reading CDs. DVD-ROM drive for reading CDs and DVDs. DVD/CD-RW combo drive for reading CDs and DVDs, and writing to CD-Rs and CD-RWs..
2	Optical disc read indicator	Light emitting diode (LED) that indicates when an optical disc is being read.
3	Optical drive eject button	Press the eject button to remove a disc from the optical drive.
4	Optical drive emergency eject hole	Used to eject an optical disc when the computer is turned off.
5	Left Latch	Locks and releases the lid.(One on the right and one on the left)
6	Floppy drive	Accepts 3.5 inch floppy disk.
7	PC card eject button	Press the eject button to remove a PC card from the PC card slot.
8	PC card slot	The slot supports a standard Type II PC card (PCMCIA).







## Right view



#	Item	Description
1	Right Latch	Locks and releases the lid.(One on the right and one on the left)
2	Speaker/Headphone-out jack 	Connects to audio line-out devices (e.g.,speakers, headphones).
3	Line-in/Mic-in jack 	Accepts audio line-in devices (e.g., audio CD player, stereo walkman). Selection is through the OS Windows mixer.
4	IEEE 1394 port 	Connects to an IEEE 1394 device.
5	IEEE 1394 port 	Connects to an IEEE 1394 device.
6	USB ports 	2 ports for connecting USB 2.0 devices.
7	DC-in jack	Connects the AC adapter.

## Rear view



#	Item	Description
1	USB ports 	2 ports for connecting USB 2.0 devices.
2	Modem jack 	Connects the built-in fax/data modem to a phone line.
3	S-video 	Connects to a television or display device with S-video input.
4	External display port	Connects an external (VGA) display devices monitor.
5	COM port	Connects to other serial interface devices.
6	Network jack 	Connects to an Ethernet 10/100-based network.
7	Parallel port 	Connects a parallel device, such as a printer.
8	PS2 port 	Connects to a PS2 mouse/ keyboard
9	Kensington lock slot	For attaching a security connector.



---

## Bottom view



#	Item	Description
1	Battery cover	Protects the battery bay.
2	Sub-woofer	Enhance the audio quality.
3	Ventilation slots	Enables the computer to stay cool, even after prolonged use.

# Main Board Layout

BOARD LAYOUT-TOP

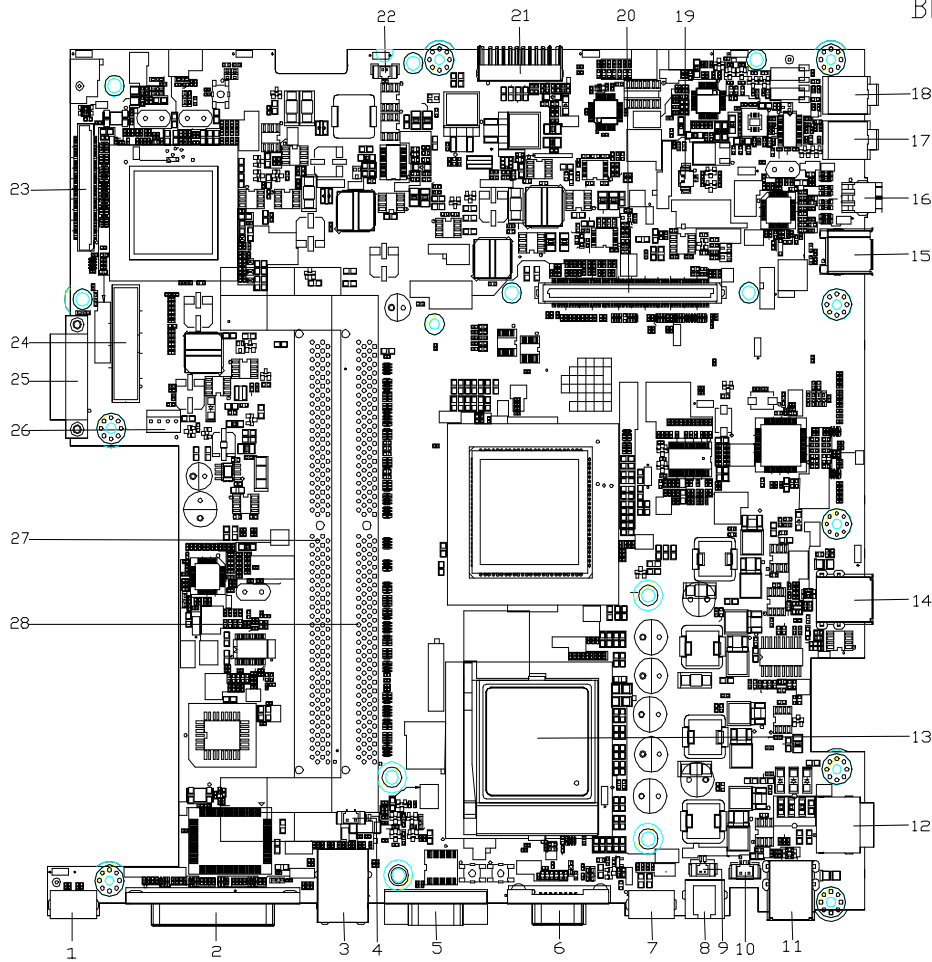

1	PS2 PORT
2	PARALLEL PORT
3	LAN CONNECTOR
4	CPU FAN CONNECTOR
5	COM1 PORT
6	VGA PORT
7	S-VIDEO PORT
8	MODEM CONNECTOR
9	MDC CONNECTOR
10	SYSTEM FAN CONNECTOR
11	USB PORT
12	DC IN CONNECTOR
13	CPU SOCKET
14	USB PORT
15	1394 CONNECTOR
16	MINI 1394 CONNECTOR
17	MIC CONNECTOR
18	LINE OUT CONNECTOR
19	WOOFER CONNECTOR
20	VGA BOARD CONNECTOR
21	BATTERY CONNECTOR
22	RTC BATTERY CONNECTOR
23	PCI BOARD CONNECTOR
24	HDD CONNECTOR
25	CD/DVD-ROM MODULE CONNECTOR
26	HDD POWER CONNECTOR
27	DDR RAM SOCKET-1
28	DDR RAM SOCKET-2

# Hardware Specifications and Configurations

## Processor

Item	Specification
Type	Pentium 4/Celeron
Socket	478
Speed	1.8G~3.06G
Minimum operating speed	0 MHz (If <b>Stop CPU Clock in Sleep State in BIOS Setup</b> is set to <b>Enabled</b> .)
Voltage	Processor voltage can be detected by the system without setting any jumper.

## BIOS

Item	Specification
BIOS code programmer	PhoenixBIOS
BIOS version	
BIOS ROM type	Flash ROM
BIOS ROM size	4MB
BIOS ROM package	32-pin PLCC package
Support protocol	PCI 2.2, DMI 2.00.1, E-IDE, ACPI 1.0, ESCD 1.03, ANSI ATA 3.0, PnP 1a, Bootable CD-ROM 1.0, ATAPI

**NOTE:** The BIOS can be overwritten/upgraded using the AFLASH utility.

## BIOS Hotkey List

Hotkey	Function	Description
m	Enter BIOS Setup Utility	Press while the system is booting to enter BIOS Setup Utility.

This section has two table lists, system memory specification and the possible combinations of memory module.

### System Memory

Item	Specification
Memory socket number	2 sockets (4 banks)
Support memory size per socket	128MB / 256MB/ 512MB / 1GB
Support maximum memory size	1G x2
Support memory type	DDR SDRAM
Support memory speed	133MHz (PC133) (for Local Bus speed 133MHz)
Support memory voltage	2.5 V
Support memory module package	184-pin Desktop Long-DIMM
Support to parity check feature	Yes
Support to Error Correction Code (ECC) feature	Yes
Memory module combinations	You can install memory modules in any combination as long as they match the above specifications.

### Memory Combinations

Slot	Memory Module	Total Memory
Slot 1	128, 256, 512MB, 1G	128MB~1G
Slot 2	128, 256, 512MB, 1G	128MB~1G
<b>Maximum System Memory Supported</b>		128MB~2G

### Cache Memory

Item	Specification
First-Level Cache Configurations	
Cache function control	Enable/Disable by BIOS Setup
Second-Level Cache Configurations	
L2 Cache RAM type	PBSRAM
L2 Cache RAM size	256/512KB
L2 Cache RAM speed	One-half the processor core clock frequency
L2 Cache RAM voltage	
L2 Cache function control	Enable/Disable by BIOS Setup
L2 Cache scheme	Fixed in write-back

### Video Memory

Item	Specification
Memory size	64 MB
Fixed on-board or upgradeable	Fixed on-board (nVIDIA) or UMA Memory (SiS M650)

This section has two table lists, the video interface specification and its supported display modes.

### Video Interface

Item	Specification
Video controller	SiS M650 or nVIDIA NV18M

## Video Interface

Item	Specification
Video controller resident bus	AGP bus
Video interface support	Video YUV texture in all texture formats H/W DVD accelerator

Display Screen Resolution	Refresh Rate (Hz)	Hor. Scan (KHz)	Pixel Clock (MHz)
640x480	60	31.5	25.2
640x480	72	37.4	32.0
640x480	75	37.5	31.5
640x480	85	43.3	36.0
640x480	120	63.7	55.0
800x600	56	35.2	36.0
800x600	60	37.8	39.9
800x600	72	48.0	50.0
800x600	75	46.9	49.5
800x600	85	53.7	56.2
800x600	100	62.5	67.5
800x600	120	76.1	81.0
800x600	160	101.9	110.0
1024x768	70	56.5	75.0
1024x768	75	60.0	78.8
1024x768	100	79.0	110.0
1280x1024	43	50.0	80.0
1280x1024	60	64.0	110.0
1280x1024	85	91.2	157.5
1600x1200	60	76.2	156.0
1600x1200	85	106.2	229.5

## Audio Interface

Item	Specification
Audio controller	SiS962
Audio controller resident bus	AC'97
Audio function control	Enable/disable by OS Setup
Mono or stereo	Stereo
Resolution	20 bits
Compatibility	Sound Blaster Pro/16 compatible Mixed digital and analog high performance chip Enhanced stereo full duplex operation High performance audio accelerator and AC'97 support Full native DOS games compatibility Virtual FM enhances audio experience through real-time FM-to-Wavetable conversion MPU-401(UART mode) interface for wavetable synthesizers and MIDI devices Integrated dual game port Meets AC'97 and WHQL specifications

## Audio Interface

Item	Specification
Music synthesizer	Yes, internal FM synthesizer
Sampling rate	48 KHz (max.)
MPU-401 UART support	Yes
Microphone jack	Supported
Headphone jack	Supported

## IDE Interface

Item	Specification
IDE controller	SiS962
IDE controller resident bus	PCI bus
Number of IDE channel	2
Support IDE interface	E-IDE (up to PIO mode-4 and Ultra DMA 33/66), ANSIS ATA rev.3.0 ATAPI
Support bootable CD-ROM	Yes

## Floppy disk drive Interface

Item	Specification
Floppy disk drive controller	SMSC LPC47M192
Floppy disk drive controller resident bus	LPC interface
Support FDD format	360KB, 720KB, 1.2MB, 1.44MB, 2.88MB

## Parallel Port

Item	Specification
Parallel port controller	SMSC LPC47M192
Parallel port controller resident bus	LPC interface
Number of parallel ports	1
Support ECP/EPP	SPP / Bi-directional / ECP / EPP
Connector type	25-pin D-type female connector
Parallel port function control	Enable/disable by BIOS Setup
Optional ECP DMA channel (in BIOS Setup)	DMA channel 1 DMA channel 3
Optional parallel port I/O address (via BIOS Setup)	378h 278h
Optional parallel port IRQ (via BIOS Setup)	IRQ5 IRQ7

## Serial Port

Item	Specification
Serial port controller	SMSC LPC47M192
Serial port controller resident bus	LPC interface
Number of serial port	1
16550 UART support	Yes
Connector type	9-pin D-type female connector
Optional serial port I/O address (via BIOS Setup)	COM1: 2F8h, 3E8h, 2E8h

## Serial Port

Item	Specification
Optional serial port IRQ (via BIOS Setup)	COM1: IRQ 3, and 4

## Modem

Item	Specification
Software Modem	V.9.0/9.2
Modem connector type	RJ11
Full duplex	Yes

## USB Port

Item	Specification
OHCI	USB 1.1/2.0
USB Class	Support legacy keyboard for legacy mode

## Memory Address Map

Address	Size	Function
000000 - 07FFFF	512KBytes	Host Memory
080000 - 09FFFF	128KBytes	Host/PCI Memory
0A0000 - 0BFFFF	128KBytes	PCI/ISA Video Buffer Memory
0C0000 - 0CFFFF	64KBytes	Video BIOS Memory
D0000	96Kbytes	ISA Card BIOS & Buffer Memory
0E0000 - 0EFFFF	64Kbytes	BIOS Extension Memory Setup and Post Memory PCI Development BIOS
0F0000 - 0FFFFF	64Kbytes	System BIOS Memory
100000 - UPPER LIMIT		Main Memory
UPPER LIMIT - 4GBytes		PCI Memory

## PCI INTx# Assignment Map

PCI INTx	PCI Devices
INTA	AGP
INTB	1394, Carbus
INTC	AGP, Audio, Mini, Modem
INTD	LAN, Mini
INTE	USB 0 (1,1)
INTF	USB 1 (1.1)
INTG	USB 2 (1,1)
INTH	USB 3 (2,0)

## I/O Address Map

Hex Range	Devices
000-00F	DMA Controller-1
020-021	Interrupt Controller-1
040-043	System Timer
060-060	Keyboard Controller 8742
061-061	System Speaker
070-071	CMOS RAM Address and Real Time Clock
080-08F	DMA Page Register
0A0-0A1	Interrupt Controller-2
0C0-0DF	DMA Controller-2
0F0-0FF	Math Co-Processor
170-177	Secondary IDE
1F0-1F7	Primary IDE
278-27F	Parallel Printer Port 2
2F8-2FF	Serial Asynchronous Port 2
378-37F	Parallel Printer Port 1
3F0-3F5	Floppy Disk Controller
3F6-3F6	Secondary IDE
3F7-3F7	Primary IDE
3F8-3FF	Serial Asynchronous Port 1
0CF8	Configuration Address Register
0CFC	Configuration Data Register
778-77A	Parallel Printer Port 1

## IRQ Assignment Map

IRQx	System Devices	Add-On-Card Devices
IRQ0	Timer	N
IRQ1	Keyboard	N
IRQ2	Cascade Interrupt Control	N
IRQ3	Serial Alternate	Reserved
IRQ4	Serial Primary	Reserved
IRQ5	MPU-401(Alternate)	Reserved
IRQ6	Floppy Disk	Reserved
IRQ7	Parallel Port	Reserved
IRQ8	Real Time Clock	N
IRQ9	N	Reserved
IRQ10	N	Reserved
IRQ11	N	Reserved
IRQ12	PS/2 Mouse	Reserved
IRQ13	Math Coprocessor Exception	N
IRQ14	Primary IDE	Reserved
IRQ15	Secondary IDE	Reserved

**NOTE:** N - Not be used



## APIC mode

PCI x	System Devices	Add-On-Card Devices
PCI 16	VGA	
PCI 17	1394, Carbus	
PCI 18	Modem, WLAN (Mini PCI), Audio	
PCI 19	LAN	
PCI 20	USB 0 (1,1)	
PCI 21	USB 1 (1,1)	
PCI 22	USB 2 (1,1)	
PCI 23	USB 3 (2,0)	

## DRQ Assignment Map

DRQx	System Devices	Add-On-Card Devices
DRQ0	N	Reserved
DRQ1	LPT (ECP mode)	Reserved
DRQ2	FDD	N
DRQ3	N	Reserved
DRQ4	Cascade	N
DRQ5	N	Reserved
DRQ6	N	Reserved
DRQ7	N	Reserved

**NOTE:** N - Not be used

## Main Board Major Chips

Item	Controller
System core logic	SiS650 / SiS962
Video controller	SiS650
Super I/O controller	SiS962
Audio controller	SiS650
LAN controller	SiS650
HDD controller	Built in SiS650
Keyboard controller	Built in SiS650
RTC	Built in SiS650

## Environmental Requirements

Item	Specifications
Temperature	
Operating	+10 ~ +35°C
Non-operating	-20 ~ +60°C (Storage package)
Humidity	
Operating	20% to 80% RH
Non-operating	20% to 80% RH
Vibration	
Operating (unpacked)	5 ~ 16 Hz: 0.015 mm 16 ~ 250 Hz: 0.21 G

---

### Environmental Requirements

Item	Specifications
Non-operating (packed)	5 ~ 27.1 Hz: 0.6 G 27.1 ~ 50 Hz: 0.016 mm 50 ~ 500 Hz: 2 G

### Mechanical Specifications

Item	Specification
Weight One 3 ½ FDD and one 3.5 HDD (without packing)	Varied by local configuration
Dimensions (main footprint)	N/A

---

## Power Management Function (ACPI support function)

### Device Standby Mode

- Independent power management timer for hard disk drive devices (0-15 minutes, time step=1 minute).
- Hard disk drive goes into Standby mode (for ATA standard interface).
- Disable V-sync to control the VESA DPMS monitor.
- Resume method: device activated (Keyboard for DOS, keyboard & mouse for Windows).
- Resume recovery time: 3-5 sec.

### Global Standby Mode

- Global power management timer (2-120 minutes, time step=10 minute).
- Hard disk drive goes into Standby mode (for ATA standard interface).
- Disable H-sync and V-sync signals to control the VESA DPMS monitor.
- Resume method: Return to original state by pushing external switch button, modem ring in, keyboard and mouse for APM mode.
- Resume recovery time: 7-10 sec.

### Suspend Mode

- Independent power management timer (2-120 minutes, time step=10 minutes) or pushing external switch button.
- CPU goes into SMM.
- CPU asserts STPCLK# and goes into the Stop Grant State.
- LED on the panel turns amber colour.
- Hard disk drive goes into SLEEP mode (for ATA standard interface).
- Disable H-sync and V-sync signals to control the VESA DPMS monitor.
- Ultra I/O and VGA chip go into power saving mode.
- Resume method: Return to original state by pushing external switch button, modem ring in, keyboard and mouse for APM mode.
- Return to original state by pushing external switch button, modem ring in and USB keyboard for ACPI mode.

### ACPI

- ACPI specification 1.0.
- S0, S1, S3 and S5 sleep state support.
- On board device power management support.
- On board device configuration support.

## System Utilities

### BIOS Setup Utility

The BIOS Setup Utility is a hardware configuration program built into your computer's BIOS (Basic Input/Output System).

Your computer is already properly configured and optimized, and you do not need to run this utility. However, if you encounter configuration problems, you may need to run Setup. Please also refer to Chapter 4 Troubleshooting when problem arises.

To activate the BIOS Utility, press **m** during POST (when "Press <F2> to enter Setup" message is prompted on the bottom of screen).

Press **m** to enter setup; press <C> to boot from CD-ROM; press <F12> to change boot device.

PhoenixBIOS Setup Utility						
Info.	Main	System Devices	Security	Boot	Exit	
<b>CPU Type:</b> Intel Pentium(R) 4 CPU 2.66GHz <b>CPU Speed:</b> 2660MHz  <b>HDD1 Model Name:</b> <b>HDD1 Serial Number:</b> <b>ATAPI Device:</b> <b>System BIOS Ver:</b> A3Axx <b>VGA BIOS Ver:</b> <b>KBC Ver:</b> x.x <b>Serial Num:</b> xxxxxxxxxxxxxxxxxxxxxxxxx <b>Asset Tag Number:</b> <b>Product Name:</b> Aspire 1700 <b>Manufacture Name:</b> acer <b>UUID:</b> xxxxxxxxxxxxxxxxxxxxxxxxxxxxxxxxx						
<b>F1 Help</b> ↑↓ <b>Select Item</b> <b>F5/F6 Change Values</b> <b>F9 Setup Defaults</b> <b>Esc Exit</b> ←→ <b>Select Menu</b> <b>Enter Select</b> ▶ <b>Sub-Menu</b> <b>F10 Save and Exit</b>						

---

## Navigating the BIOS Utility

There are six menu options: Info., Main, System Devices, Security, Boot, and Exit.

Follow these instructions:

- To choose a menu, use the cursor left/right keys (zx).
- To choose a parameter, use the cursor up/down keys ( wy).
- To change the value of a parameter, press por q.
- A plus sign (+) indicates the item has sub-items. Press e to expand this item.
- Press ^ while you are in any of the menu options to go to the Exit menu.
- In any menu, you can load default settings by pressing t. You can also press u to save any changes made and exit the BIOS Setup Utility.

**NOTE:** You can change the value of a parameter if it is enclosed in square brackets. Navigation keys for a particular menu are shown on the bottom of the screen. Help for parameters are found in the Item Specific Help part of the screen. Read this carefully when making changes to parameter values.

This menu provides you the information of the system.

**Info.**

PhoenixBIOS Setup Utility						
Info.	Main	System Devices	Security	Boot	Exit	
<p><b>CPU Type:</b> Intel Pentium(R) 4 CPU 2.66GHz  <b>CPU Speed:</b> 2660MHz</p> <p><b>HDD1 Model Name:</b>  <b>HDD1 Serial Number:</b>  <b>ATAPI Device:</b></p> <p><b>System BIOS Ver:</b> A3Axx  <b>VGA BIOS Ver:</b>  <b>KBC Ver:</b> x.x  <b>Serial Num:</b> xxxxxxxxxxxxxxxxxxxxxxxxx  <b>Asset Tag Number:</b>  <b>Product Name:</b> Aspire 1700  <b>Manufacture Name:</b> acer  <b>UUID:</b> xxxxxxxxxxxxxxxxxxxxxxxxxxxxxxxxx</p>						
<p><b>F1 Help</b>    ↑↓ <b>Select Item</b>    <b>F5/F6 Change Values</b>    <b>F9 Setup Defaults</b>  <b>Esc Exit</b>    ←→ <b>Select Menu</b>    <b>Enter Select</b>    ▶ <b>Sub-Menu</b>    <b>F10 Save and Exit</b></p>						

Parameter	Description
Floppy Disk Drive	Shows floppy drive type informaiton.
Serial Number	This field displays the serial number of this unit.
UUID Number	UUID=32bytes

## Main

The Main screen displays a summary of your computer hardware information, and also includes basic setup parameters. It allows the user to specify standard IBM PC AT system parameters.

PhoenixBIOS Setup Utility					
Info.	Main	System Devices	Security	Boot	Exit
<b>System Time:</b> [HH:MM:SS] <b>System Date:</b> [MM/DD/YYYY] <b>System Memory:</b> 640 KB <b>Extended memory:</b> [64 MB]  <b>Fast Boot:</b> [Enabled] <b>Power On Display:</b> [Auto] <b>LCD Auto Dimm:</b> [Enabled] <b>USB BIOS legacy Support:</b> [Enabled] <b>Wake On LAN From Power Off:</b> [Disabled]					<b>Item Specific Help</b>
<b>F1 Help</b> ↑↓ <b>Select Item</b> <b>F5/F6 Change Values</b> <b>F9 Setup Defaults</b> <b>Esc Exit</b> ←→ <b>Select Menu</b> <b>Enter Select</b> ▶ <b>Sub-Menu</b> <b>F10 Save and Exit</b>					

**NOTE:** The screen above is for reference only. Actual values may differ.

The table below describes the parameters in this screen. Settings in **boldface** are the default and suggested parameter settings.

Parameter	Description	Format/Option
System Time	Sets the system time.	Format: HH:MM:SS (hour:minute:second) System Time
System Date	Sets the system date.	Format MM/DD/YYYY (month/day/year) System Date
System Memory	This field reports the memory size of the system. Memory size is fixed to 640MB	
Extended Memory	This field reports the memory size of the extended memory in the system. Extended Memory size=Total memory size-1MB	
Video Memory	Shows the VGA memory size. The default value is set to 32MB	Option: 1/4/8/ <b>16</b> /32MB
Fast Boot	Determines if Customer Logo will be displayed or not; shows Summary Screen is disabled or enabled.  Enabled: Customer Logo is displayed, and Summary Screen is disabled. Disabled: Customer Logo is not displayed, and Summary Screen is enabled.	Option: <b>Enabled</b> or Disabled
Internal Hard Disk	Shows the hard disk types and capacity. If there is no hard disk present or unknown type, "None" should be shown on this field, otherwise the capacity must be shown.	
Power on display	Auto: During power process, the system will detect if any display device is connected on external video port. If any external display device is connected, the power on display will be in CRT (or projector) only mode. Otherwise it will be in LCD only mode.  Both: Simultaneously enable both the integrated LCD screen and the system's external video port (for an external CRT or projector).	Option: <b>Auto</b> or Both
LCD Auto Dim	Determines if the system will automatically dim the LCD brightness in order to save power when AC is not present.	Option: <b>Enabled</b> or Disabled

**NOTE:** The sub-items under each device will not be shown if the device control is set to disable or auto. This is because the user is not allowed to control the settings in these cases.



# System Devices

The System Devices screen contains parameters involving your hardware devices. It also provides advanced settings of the system.

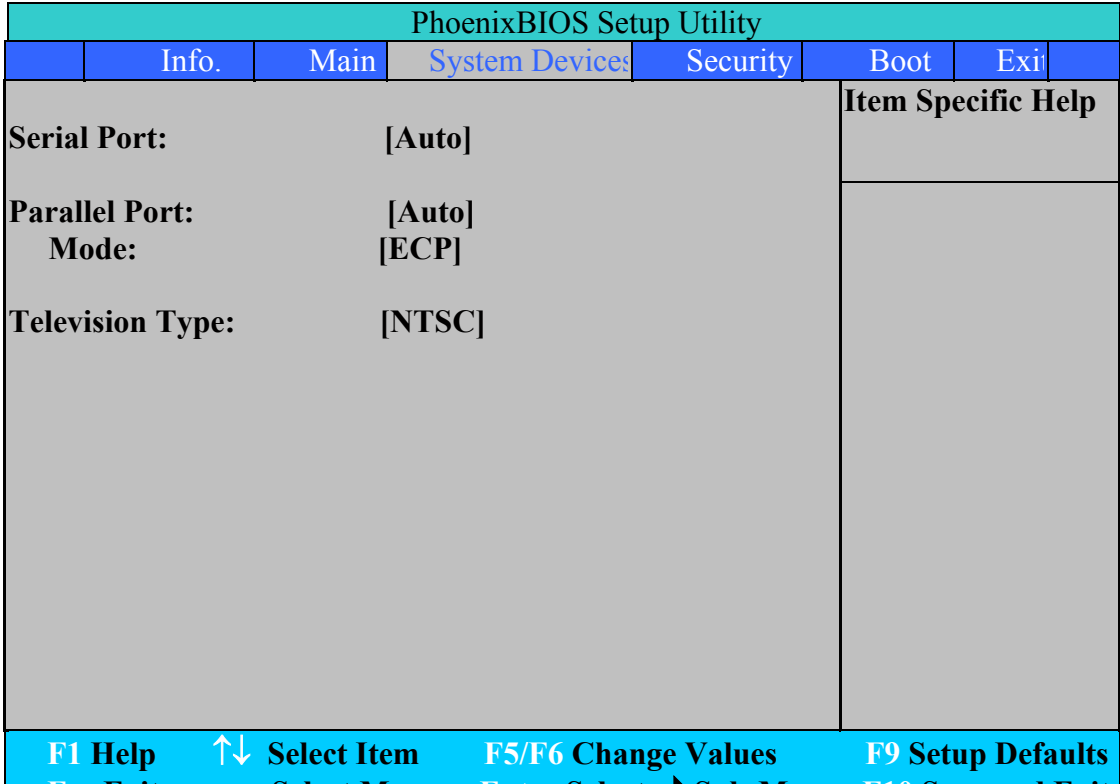

The table below describes the parameters in the screen. Settings in **boldface** are the default and suggested parameter settings.

Parameter	Description	Options
Serial Port	Enables, disables or auto detects the serial port.	<b>Enabled</b> /Disabled/Auto
Parallel Port	Enables, disables or auto detects the parallel port.	<b>Enabled</b> /Disabled/Auto
Mode	Sets the operation mode of the parallel port.	<b>ECP</b> , EPP, Normal or Bi-directional
Television Type		
Internal Touchpad	Determines whether or not to disable the internal pointing device as the PS/2 mouse is connected.	<b>Both</b> or Auto
Infrared Port (FIR)	Enables, disables or auto detects the infrared port.	<b>Enabled</b> /Disabled/Auto

## Security

The Security screen contains parameters that help safeguard and protect your computer from unauthorized use.

PhoenixBIOS Setup Utility							
Info.	Main	System Devices	Security	Boot	Exit	Item Specific Help	
<b>User Password Is:</b> <b>Clear</b> <b>Supervisor Password Is:</b> <b>Clear</b> <b>Hard Disk Security:</b> <b>Clear</b> <b>HDD Master ID:</b>  <b>Set User Password:</b> [Enter] <b>Set Supervisor Password:</b> [Enter] <b>Set HDD Password</b> [Enter]  <b>Password on Boot:</b> [Disabled]							
<b>F1 Help</b> <b>↑↓ Select Item</b> <b>F5/F6 Change Values</b> <b>F9 Setup Defaults</b> <b>Esc Exit</b> <b>←→ Select Menu</b> <b>Enter Select</b> <b>▶ Sub-Menu</b> <b>F10 Save and Exit</b>							

The table below describes the parameters in this screen. Settings in **boldface** are the default and suggested parameter settings.

Parameter	Description	Option
User Password is	Shows the setting of the user password.	<b>Clear</b> or Set
Supervisor Password is	Shows the setting of the administrator password	<b>Clear</b> or Set
<b>HDD Password Is</b>		
<b>HDD Master ID</b>		
Set User Password	Press Enter to set the user password. When set, this password protects the BIOS Setup Utility from unauthorized access.	
Set Supervisor Password	Press Enter to set the administrator password. When set, this password protects the BIOS Setup Utility from unauthorized access.	
<b>Set HDD Password</b>		
Password on boot	Allows the user to specify whether or not a password is required to boot.	<b>Disabled</b> or Enabled

**NOTE:** When you are prompted to enter a password, you have three tries before the system halts. Don't forget your password. If you forget your password, you may have to return your notebook computer to your dealer to reset it.

---

## Setting a Password

Follow these steps as you set the user or the supervisor password:

1. Use the **w** and **y** keys to highlight the Set Supervisor Password parameter and press the **e** key. The Set Supervisor Password box appears:

Set Supervisor Password	
Enter New Password	[ ]
Confirm New Password	[ ]

2. Type a password in the “Enter New Password” field. The password length can not exceeds 8 alphanumeric characters (A-Z, a-z, 0-9, not case sensitive). Retype the password in the “Confirm New Password” field.

**IMPORTANT:** Be very careful when typing your password because the characters do not appear on the screen.

3. Press **e**.  
After setting the password, the computer sets the User Password parameter to “Set”.
4. If desired, you can opt to enable the Password on boot parameter.
5. When you are done, press **u** to save the changes and exit the BIOS Setup Utility.

## Removing a Password

Follow these steps:

1. Use the **w** and **y** keys to highlight the Set Supervisor Password parameter and press the **e** key. The Set Password box appears:

Set Supervisor Password	
Enter current password	[ ]
Enter New Password	[ ]
Confirm New Password	[ ]

2. Type the current password in the Enter Current Password field and press **e**.
3. Press **e** twice **without** typing anything in the Enter New Password and Confirm New Password fields. The computer then sets the Supervisor Password parameter to “Clear”.
4. When you have changed the settings, press **u** to save the changes and exit the BIOS Setup Utility.

## Changing a Password

1. Use the **w** and **y** keys to highlight the Set Supervisor Password parameter and press the **e** key. The Set Password box appears:

---

Set Supervisor Password		
Enter current password	[	]
Enter New Password	[	]
Confirm New Password	[	]

2. Type the current password in the Enter Current Password field and press `e`.
3. Type a password in the Enter New Password field. Retype the password in the Confirm New Password field.
4. Press `e`. After setting the password, the computer sets the User Password parameter to "Set".
5. If desired, you can enable the Password on boot parameter.
6. When you are done, press `u` to save the changes and exit the BIOS Setup Utility.

If the verification is OK, the screen will display as following.

Setup Notice
Changes have been saved.
[ continue]

The password setting is complete after the user presses `u`.

If the current password entered does not match the actual current password, the screen will show you the Setup Warning.

Setup Warning
Invalid password
Re-enter Password
[ continue]

If the new password and confirm new password strings do not match, the screen will display the following message.

Setup Warning
Password do not match
Re-enter Password

## Boot

This menu allows the user to decide the order of boot devices to load the operating system. Bootable devices includes the distette drive in module bay, the onboard hard disk drive and the CD-ROM in module bay.

PhoenixBIOS Setup Utility							
	Info.	Main	System Devices	Security	Boot	Exit	
<b>CD-ROM/DVD-ROM</b>						<b>Item Specific Help</b>	
<b>Hard Drive</b>							
<b>Removable Device</b>							
<b>Boot to LAN</b>							
<b>F1 Help    ↑↓ Select Item    F5/F6 Change Values    F9 Setup Defaults</b>							
<b>Esc Exit   ←→ Select Menu   Enter Select   ▶ Sub-Menu   F10 Save and Exit</b>							

## Exit

The Exit screen contains parameters that help safeguard and protect your computer from unauthorized use.

PhoenixBIOS Setup Utility					
Info.	Main	System Devices	Security	Boot	Exit
<b>Exit Saving Changes</b> <b>Exit Discarding Changes</b> <b>Load Setup Defaults</b> <b>Discard Changes</b> <b>Save Changes</b>					
<b>F1 Help</b> ↑↓ <b>Select Item</b> <b>F5/F6 Change Values</b> <b>F9 Setup Defaults</b> <b>Esc Exit</b> ←→ <b>Select Menu</b> <b>Enter Select</b> ▶ <b>Sub-Menu</b> <b>F10 Save and Exit</b>					

The table below describes the parameters in this screen.

Parameter	Description
Exit Saving Changes	Exit System Setup and save your changes to CMOS.
Exit Discarding Changes	Exit utility without saving setup data to CMOS.
Load Setup Default	Load default values for all SETUP item.
Discard Changes	Load previous values from CMOS for all SETUP items.
Save Changes	Save Setup Data to CMOS.

## Machine Disassembly and Replacement

---

This chapter contains step-by-step procedures on how to disassemble the notebook computer for maintenance and troubleshooting. To disassemble the computer, you need the following tools:

1. An ESD mat
2. A Philips screw driver
3. A tweezers
4. And a hex screw driver

**NOTE:** Use an ESD wristband to avoid the risk of electronic discharge

---

## General Information

### Before You Begin

Before proceeding with the disassembly procedure, make sure that you do the following:

1. Turn off the power to the system and all peripherals.
2. Unplug the AC adapter and all power and signal cables from the system.
3. Jewelry such as watches, rings and bracelets should be removed before service disassembly.



# Disassembly Procedure Flowchart

The flowchart on the succeeding page gives you a graphic representation on the entire disassembly sequence and instructs you on the components that need to be removed during servicing. For example, if you want to remove the system board, you must first remove the keyboard, then disassemble the inside assembly frame in that order.

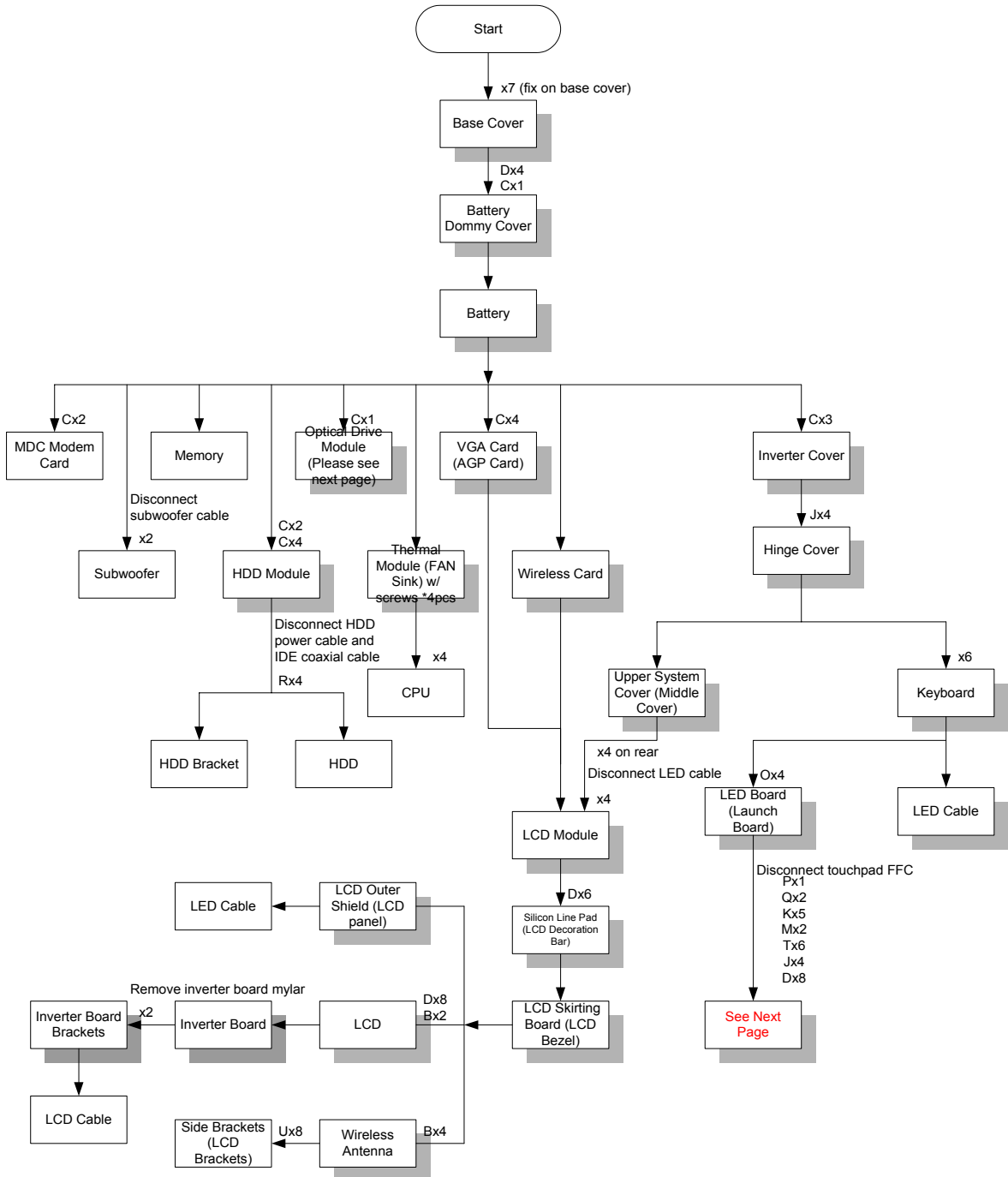

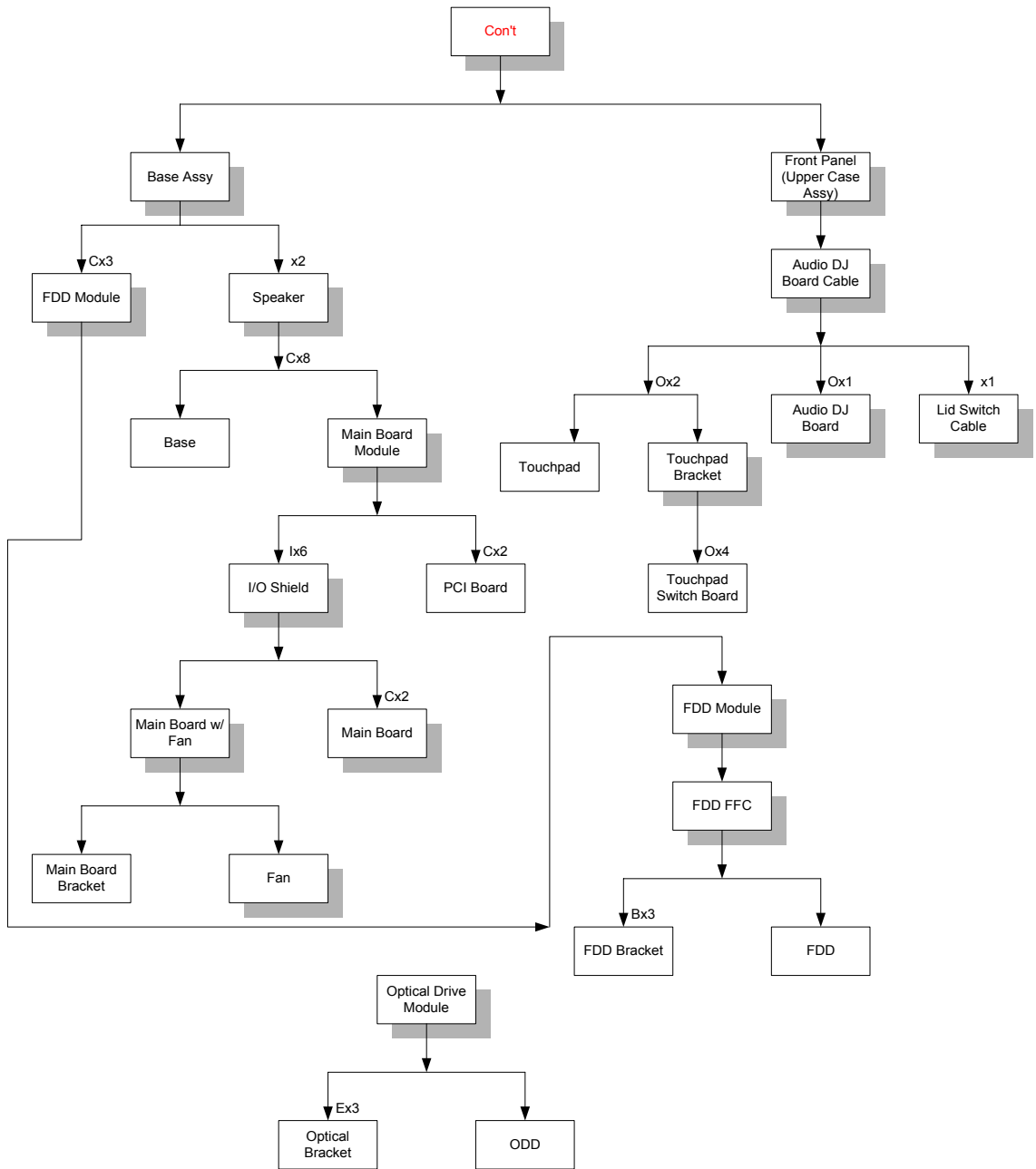

---

**Screw List**

<b>Item</b>	<b>Description</b>
A	SCREW MM30060IL67
B	SCREW MM25025ICI0
C	SCREW MM25040IL60
D	SCREW MM25060IL69
E	SCREW MM20030ICI3
F	SCREW MM20080ICI6
G	SCREW MM20100ICI3
H	SCREW MS17025B202
I	SCREW MBEA1001012
J	SCREW MF30060PB5
K	SCREW MM25070ICI5
L	SCREW MS25060ILR1
M	SCREW MS25060P527
N	SCREW MM25040ICI1
O	SCREW MS25025IBX8
P	SCREW MS251801100
Q	SCREW MS25100B371
R	SCREW MS0601BILQ1
S	HDD SCREW
T	SCREW MS25060IM01
U	SCREW MM30050ICI4

---

# Disassembling

## Remove the battery

1. Release the seven screws as shown here.
2. Remove the bottom shield plate.



3. Remove the 5 screws as shown here.
4. Remove the battery or dummy battery module.

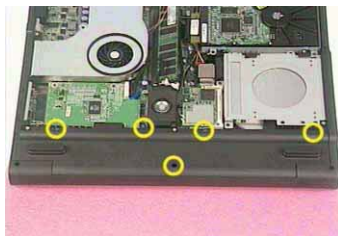

## Remove the HDD module

1. Remove the 4 screws that secure the HDD module.
2. Lift the HDD module and detach the IDE connector and power connector at the same time.



## Remove the combo drive

1. Remove the one screw as shown here.
2. Detach the Combo drive.



---

## Remove the thermal module

1. Disconnect the fan power connector.
1. Remove the three screws as shown here
2. Remove the thermal module.

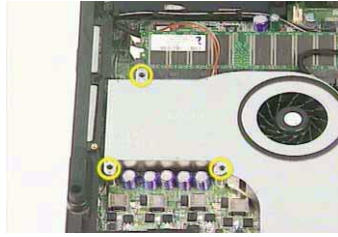

## Remove CPU

1. Open the CPU lever, remove the CPU and close the lever.

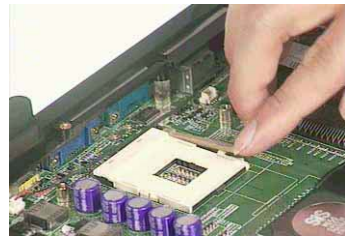
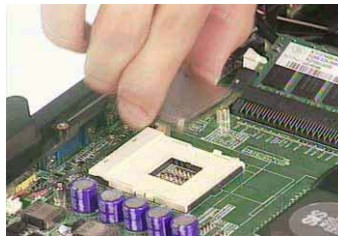
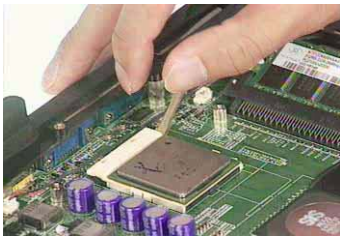

## Remove the memory

1. Remove the memory

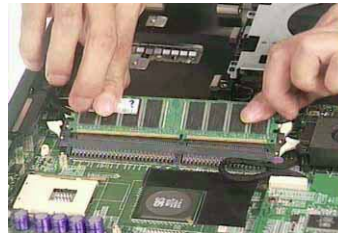
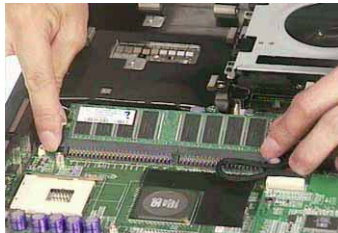

## Remove VGA card

1. Disconnect the VGA connector.
2. Release the four screws that secure the VGA card.
3. Remove the VGA card.

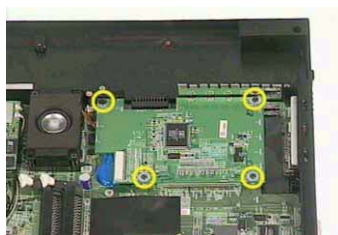



## Detach the wireless card

1. Detach the wireless card.
2. Disconnect the two wireless cables.

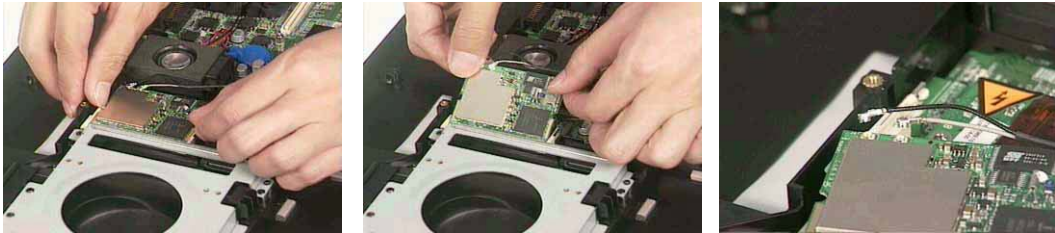

## Remove moden card

1. Remove the screws on the MDC (modem card)
2. Detach the card from the modem cable.



3. Release the cable

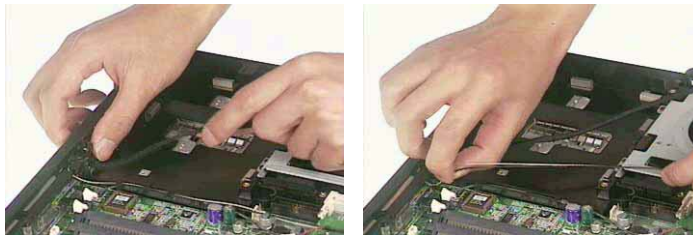

## Remove the inverter cover

1. Remove the screws as shown here.
2. Remove the inverter cover.



## Detach the upper system cover

1. Remove the two screws on the one side, and the two screws on the other. .



2. Remove the hinge covers on each side



3. Detach the upper system cover (middle cover).



## Remove the LCD module

1. Detach the LED cable from the LED board.
2. Remove the screws that secure the hinge. And the other side.



3. Detach the LCD panel from the main unit and place the panel by turning 180 degrees.
4. Release the cables by following the instructions here carefully.



## Remove the LCD panel

1. Detach the silicon line pad by following the instruction here. And the other side.

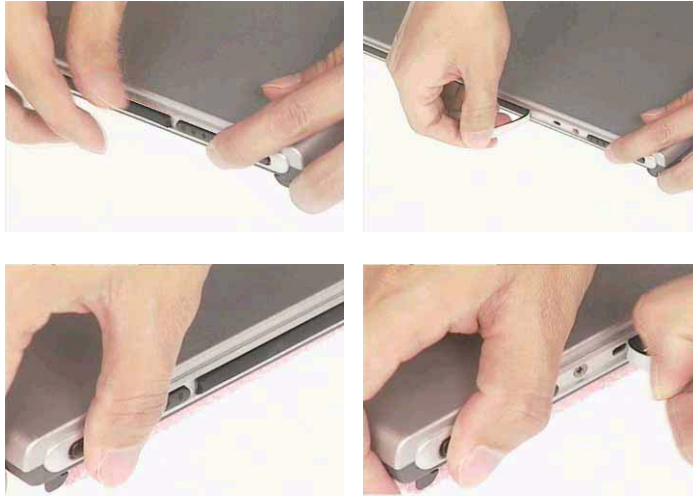

2. Unscrew the three screws on the edge of the LCD panel on both sides.

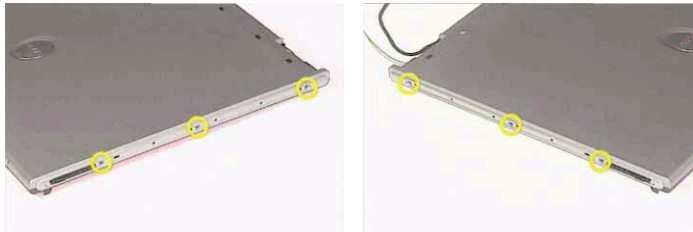

3. Detach the LCD skirting board (LCD bezel) by following the instruction here.
4. Remove the TEN screws on the side mount.
5. Remove the LCD panel.



## Remove the inverter board

1. Remove the tape and disconnect the inverter cable.

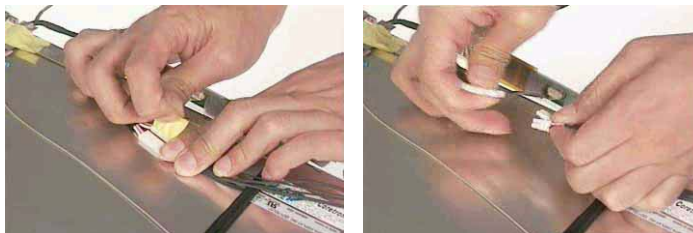



2. Follow the same procedure on the other inverter cable.



3. Disconnect the inverter power cable from the inverter board.
4. Remove the mylar that covering the inverter board.



5. Remove the two screws that secure the inverter board bracket.



## Remove the mylars

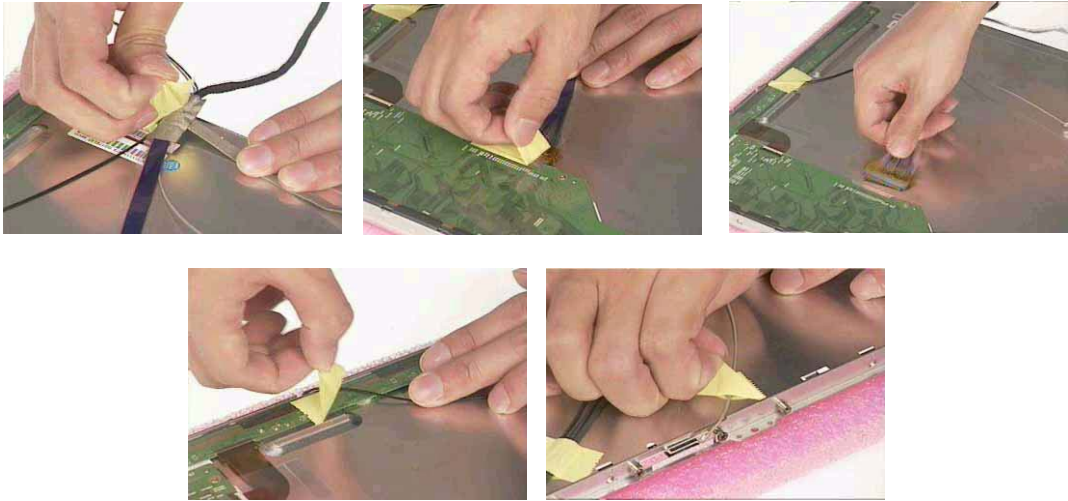

## Remove the wireless module

1. Remove the two screws that secure the wireless antenna.
2. Remove the antenna.



3. Repeat the same procedure on the other side.
4. Remove the wireless module



## Remove the side bracket

1. Remove the two screws as shown here. Then remove the side bracket.

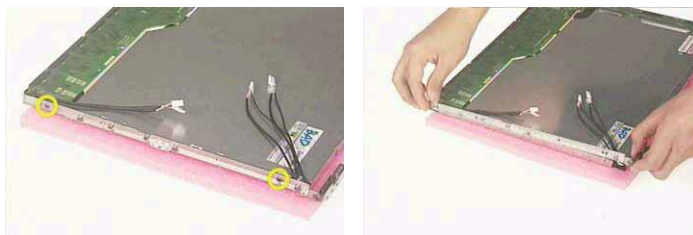

2. Repeat the same procedure on the other side bracket.



Remove the LED cable attached on the LCD outer shield.



Remove the subwoofer

1. Disconnect the subwoofer cable.
2. Remove the two screws that secure the subwoofer.
3. Remove the subwoofer.

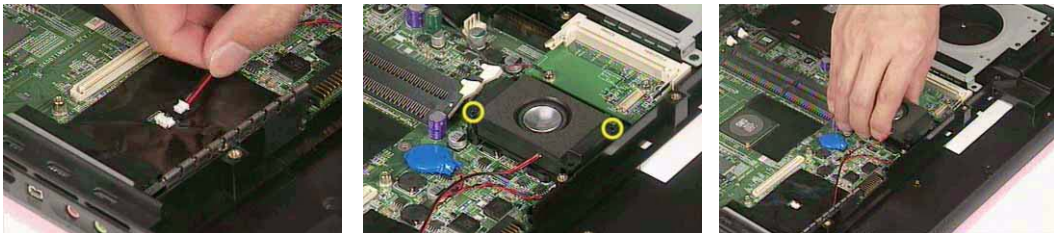

Release the MDC cable.

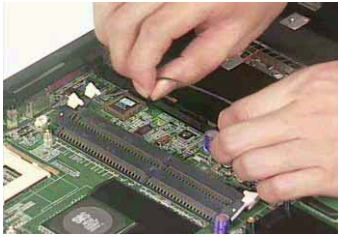

Disconnect the cable to the modem header.

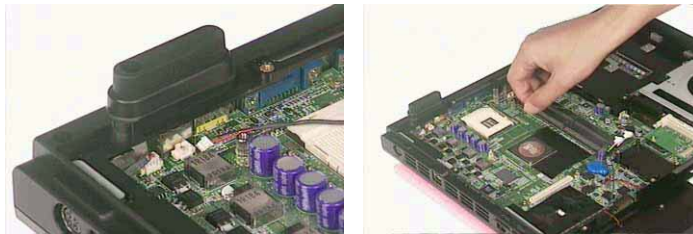

Remove the keyboard

1. Remove the six screws that secure the keyboard.
2. Remove the keyboard and disconnect the attached cable.



Remove the LED board

1. Detach the LED ribbon cable.
2. Remove the four screws that secure the LED board.



3. Lift the LED board and disconnect the LED cable at the same time.

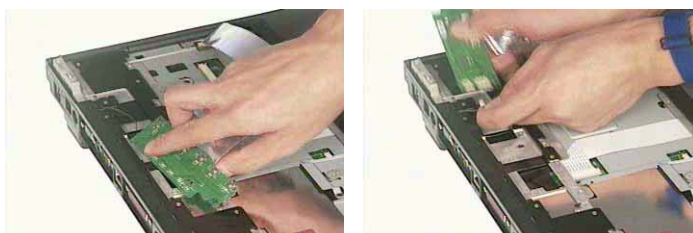



4. Disconnect the LED ribbon cable from the LED board.

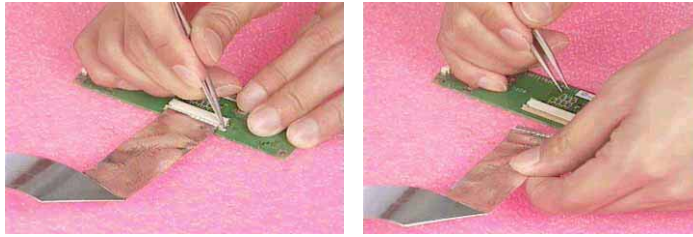

## Detach the front panel

1. Disconnect the touch pad ribbon cable.
2. Remove the three screws as shown here.



3. Turn the unit upside down, and then remove the group of FOUR, the group of EIGHT and the group of SIX screws.



4. And finally the 4 screws on the rear side.
5. Detach the front panel.

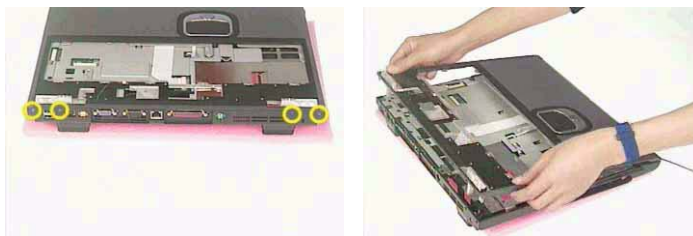

## Remove the Audio DJ board

1. Disconnect the Audio DJ ribbon cable.

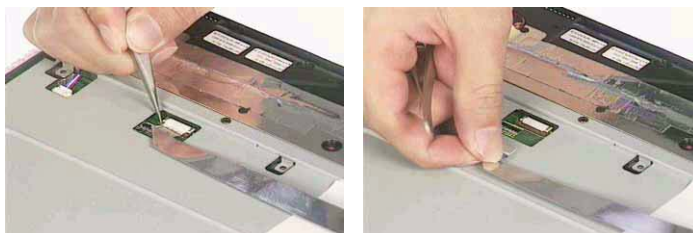

2. Disconnect the other side of the ribbon cable to the Audio DJ board.



3. Remove the screw that secures the Audio DJ board.
4. Remove the DJ board.

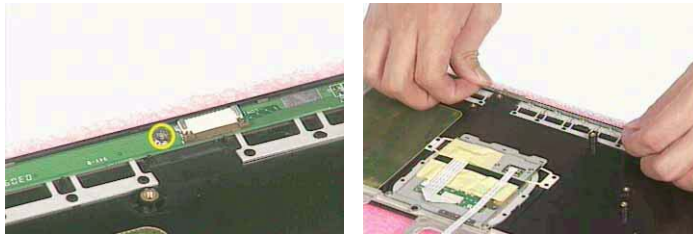

## Remove the touch pad

1. Remove the mylar here.
2. Disconnect the two ribbon cables to the touch pad.

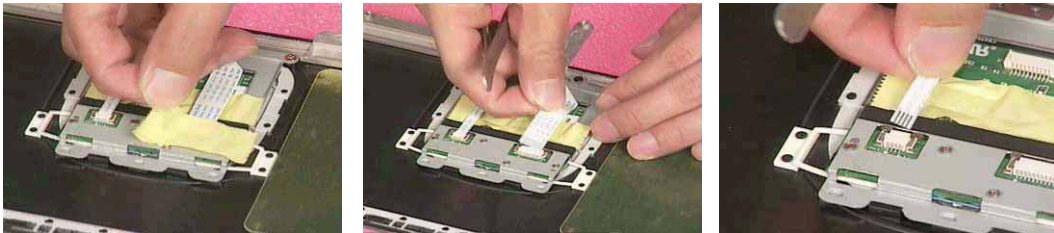

3. Remove the mylar.
4. Remove the two screws that secure the touch pad.

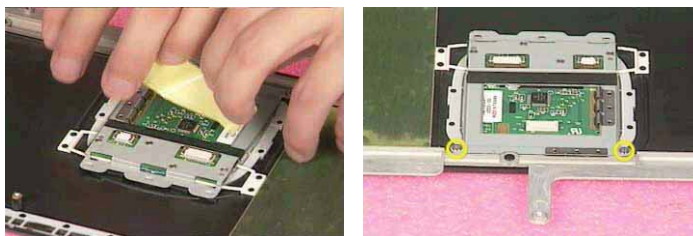

5. Remove the touch pad bracket.
6. Remove the touch pad.

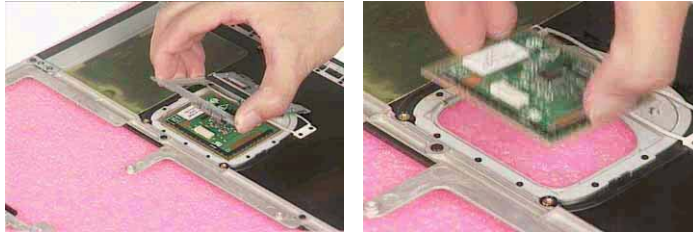

## Remove the touch pad board

1. Remove the four screws that secure the touch pad board.
2. Remove the touch pad board.

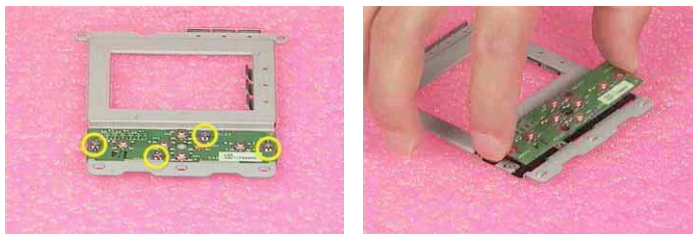

## Remove the lid switch cable

1. Disconnect the lid switch cable by releasing the screw.
2. Remove the lid switch cable.



## Remove the floppy drive

1. Disconnect the floppy cable
2. Remove the three screws
3. Remove the floppy drive.

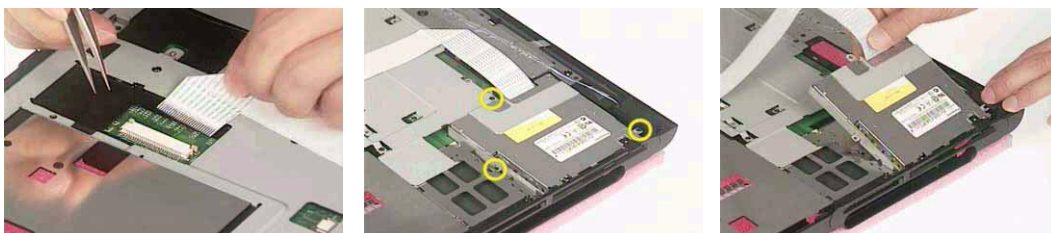



## Remove the speaker set

1. Remove the tape
2. Remove the aluminum tape (the tape can be damaged while servicing, please make sure you have a spare one).
3. Remove the tape here.

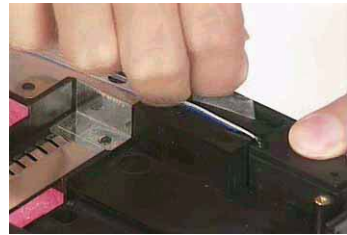
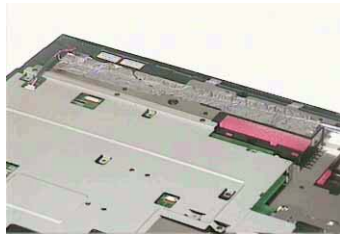

4. Disconnect the speaker cable.
5. Remove the screw as shown here.
6. And the one on the other side.

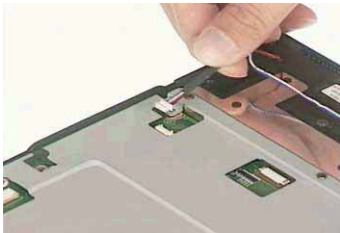

7. Remove the speaker set.



## Remove the mainboard

1. Remove the nine screws as shown
2. Detach the mainboard module from the base unit
3. Remove the screw as shown

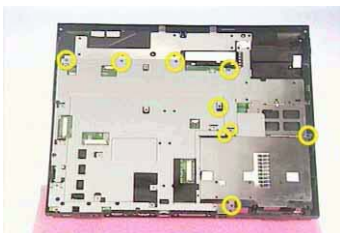



4. Remove the PCI board.
5. Remove the six screws that secure the I/O shield.
6. Remove the I/O shield.

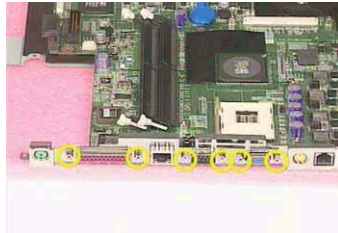

7. Disconnect the system fan power connector.
8. Remove the two screws, one on each side, that secure the mainboard.

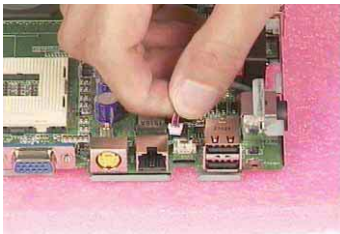

9. Remove the mainboard from the mainboard bracket.



## Remove the system fan

1. Remove the two screws that secure the system fan.
2. Remove the system fan.

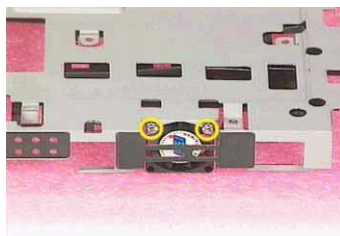

3. This completes the disassembly procedures of Aspire 1700.

## FDD Module

1. Disconnect the ribbon cable.
2. Remove the screws as shown here.



3. Remove the FDD bracket away from the floppy drive.



## HDD Module

1. Disconnect the HDD power cable and then the IDE coaxial cable.

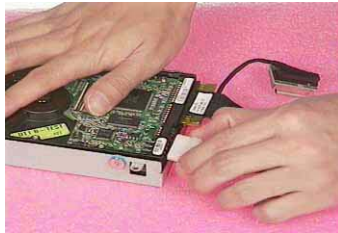

2. Remove the screws that secure the HDD, and the other side.
3. Remove the bracket from the HDD.



---

## Combo Module

1. Remove the three screws as shown here.
2. Remove the bracket.





## Machine Disassembly and Replacement

---

This chapter contains step-by-step procedures on how to disassemble the notebook computer for maintenance and troubleshooting. To disassemble the computer, you need the following tools:

1. An ESD mat
2. A Philips screw driver
3. A tweezers
4. And a hex screw driver

**NOTE:** Use an ESD wristband to avoid the risk of electronic discharge

---

## General Information

### Before You Begin

Before proceeding with the disassembly procedure, make sure that you do the following:

1. Turn off the power to the system and all peripherals.
2. Unplug the AC adapter and all power and signal cables from the system.
3. Jewelry such as watches, rings and bracelets should be removed before service disassembly.

---

## Re-assembly

### Place the system fan

1. Put the mainboard bracket on the table.
2. Place the system fan back to position.
3. Fasten the two screws for the system fan.

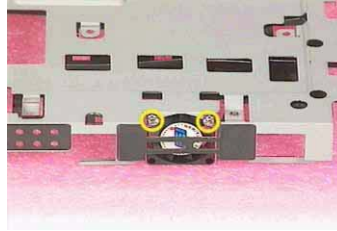
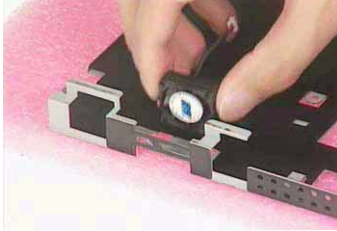

### Re-assembling the mainboard

1. Place the mainboard back to the bracket.
2. Secure the two screws on each side.



3. Reconnect the system fan power connector.
4. Place the I/O shield back to position.
5. Secure the SIX screws as shown here.

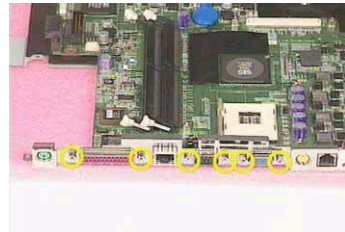
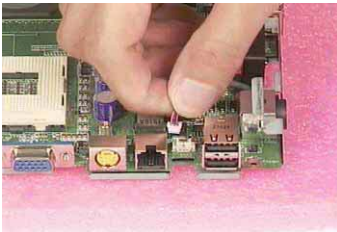

6. Place the PCI card back to position.
7. Secure the screw for the PCI card.





- Place the motherboard module back to position.
- Secure the nine screws as shown here.

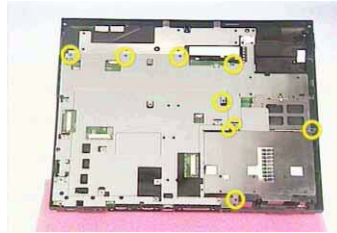

### Place the speaker set back to position

- Place the speaker set back to position
- Secure the screw on each side.



- Reconnect the speaker connector.
- Fix the wire by a tape.

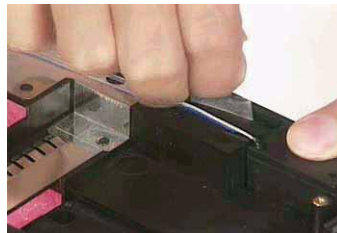
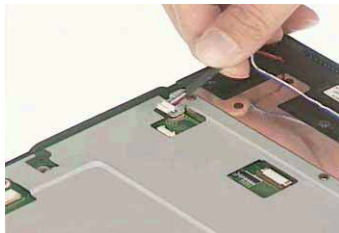

- Use an aluminum tape to avoid electro-emission.
- Secure the wire here with a tape.

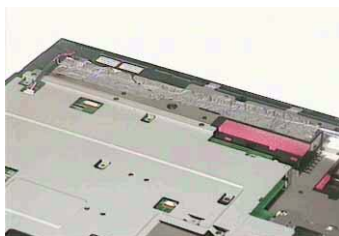



## Place the floppy module back to position

1. Place the floppy module back to position.
2. Secure the three screws for the floppy.
3. Reconnect the floppy ribbon cable.

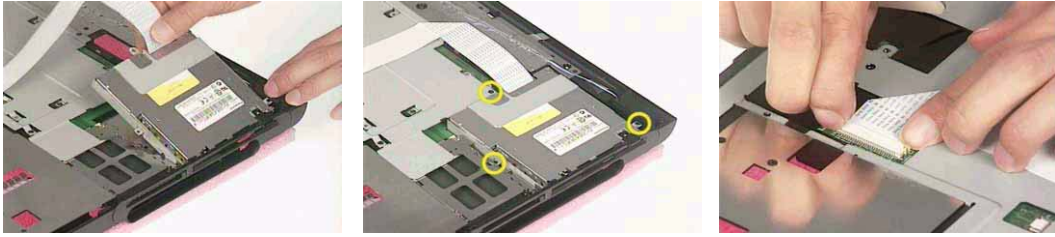

## Place the touch pad back to position

1. Place the lid switch cable back to position.
2. Secure the screw.

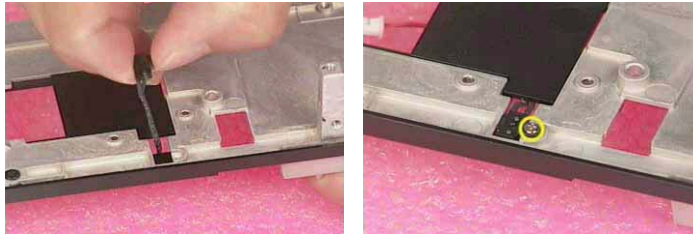

3. Place the touch pad board back to position.
4. Secure the four screws.
5. Place the touch pad back to position.



6. Place the touch pad bracket back to position.
7. Secure the two screws here.
8. Attach a tape.



## Reconnect the Audio DJ board

1. Reconnect the ribbon cable and the other.
2. Use another tape to secure.

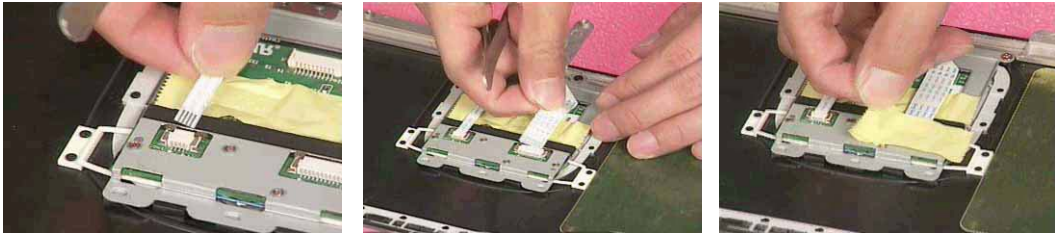

3. Place the Audio DJ board back to position.
4. Secure the screw.

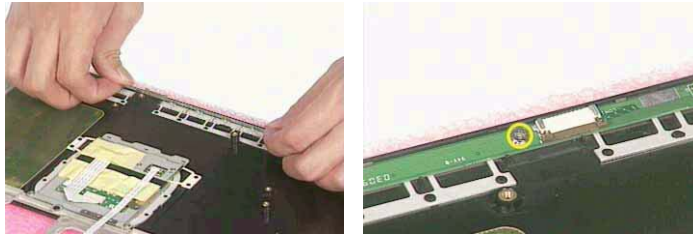

5. Reconnect the Audio DJ cable and the reconnect the other side.

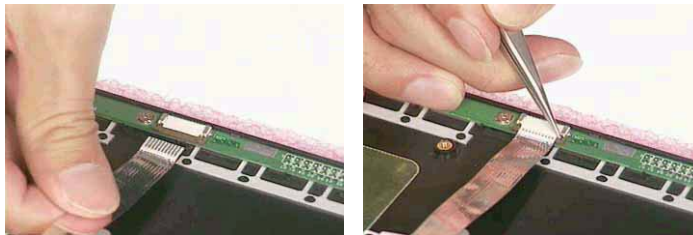

## Place the system cover back to position

1. Place the system cover back to position.
2. Secure the four screws on the rear panel.



3. Secure the group of six, the group of eight and the group of four screws as shown here.



4. Secure the three screws here.
5. Reconnect the touch pad ribbon cable.



## Reconnect the LED cable

1. Attach the LED cable to the board.
2. And the LED power cable to the board.

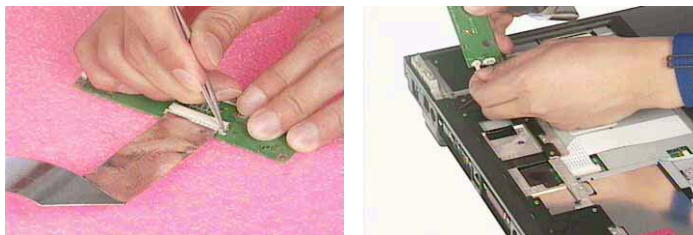

3. Secure the four screws on the LED board.
4. Reconnect the LED cable.



## Place the keyboard back to position

1. Reconnect the keyboard ribbon cable.
2. Place the keyboard back to position.
3. Secure the six screws for the keyboard.





## Place the MDC cable back to position

1. Place the MDC cable back to position.
2. Reconnect the MDC header.
3. Fix the wire by the slot.



## Reconnect the sub-woofer

1. Place the subwoofer back to position.
2. Secure the two screws for the sub-woofer.
3. Reconnect the sub-woofer connector.



## Place the LED cable back to position

1. Place the LED cable back to position.
2. Fix the wire by a tape. And the other.

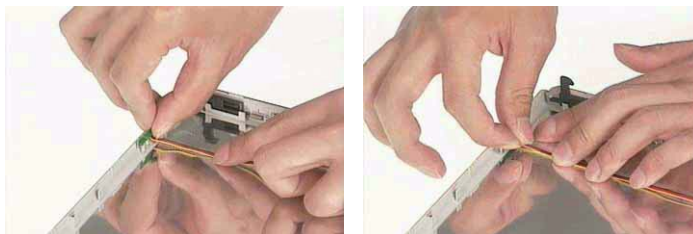

---

## Place the side mount back to position.

1. Place the side mount back to position.
2. Secure the side mount.



3. Repeat the same procedure on the other side.
4. Secure the wire with a tape.



## Place the wireless antenna back to position

1. Place the wireless antenna back to position.
2. Secure the antenna on the one side and the other.

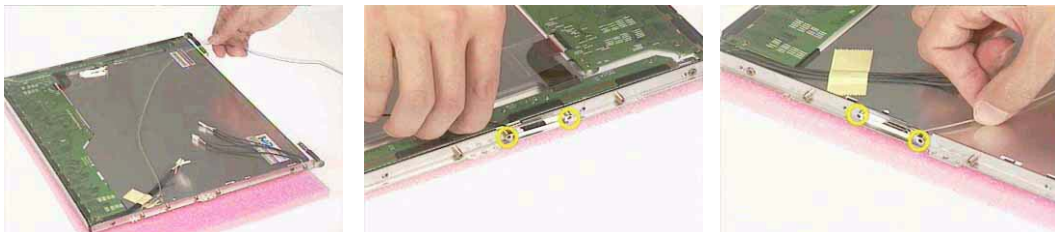

3. Secure the wireless module with a tape and the other side.

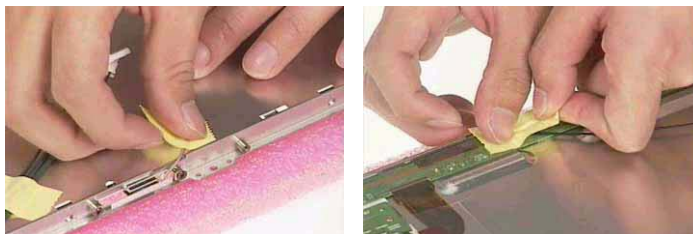

## Reattach the LCD cable

1. Reattach the LCD cable.
2. Secure the connector with a tape and the other side.



## Place the inverter board back to position

1. Place the inverter bracket back to position and the other.
2. Secure the two brackets.



3. Place the inverter board back to a mylar.
4. Reconnect the inverter power.
5. Reconnect the inverter cables.



6. Fix the wires and repeat the same procedure on the other side.





## Re-assembling the LCD module

1. Place the LCD panel back to position.
2. Secure the ten screws as shown here.
3. Fix the LCD skirting board (LCD bezel).



4. Secure the three screws on the one side, and the other.

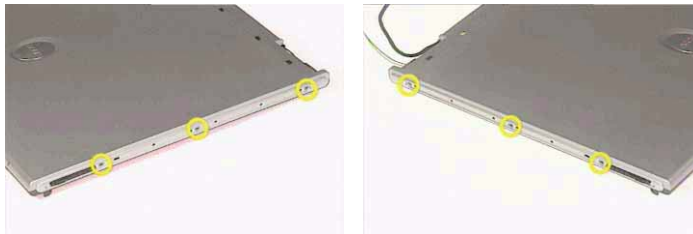

5. Attach a new silicon pad and the other.

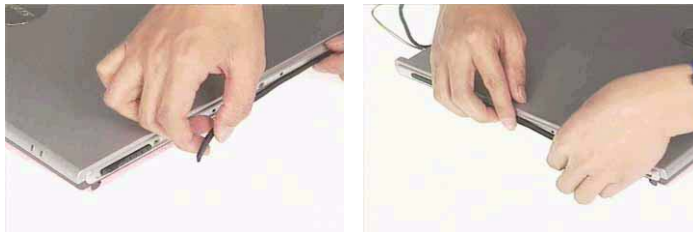

6. Insert the cables into the hole carefully.
7. Place the LCD panel back to position.



8. Secure the hinge and the other side.
9. Reconnect another LED cable.



## Place the system cover and hinge back to position

1. Place the system cover (middle cover) back to position.
2. Place the hinge cover back to position and secure the hinge cover.



3. Repeat the same procedure on the other side.



## Place the inverter cover back to position

1. Place the inverter cover back to position.
2. Secure the inverter cover.



## Reconnect the cable to the MDC card and wireless card

1. Fix the MDC cable.

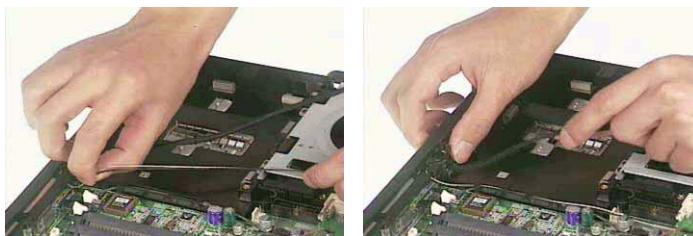



2. Reconnect the cable to the MDC card.
3. Secure the card.

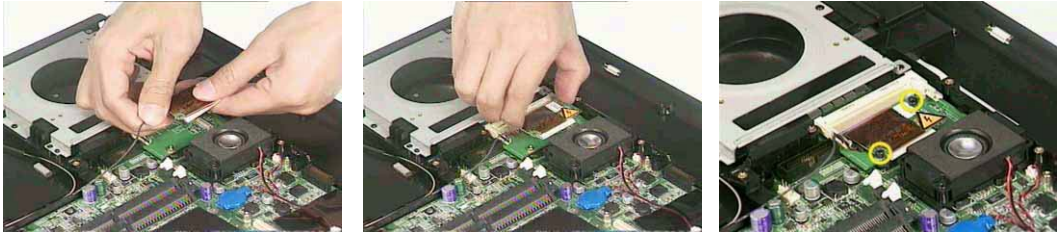

4. Reconnect the wireless cable.
5. Place the wireless card back to position.

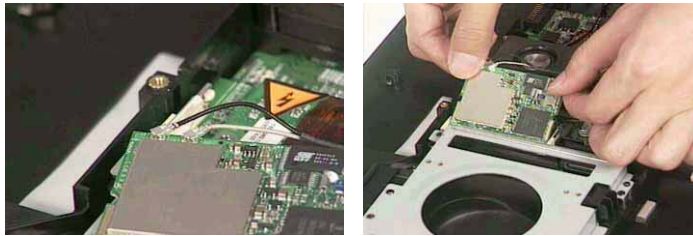

### Place the VGA card back to position.

1. Place the VGA card back to position.
2. Secure the VGA card.
3. Reconnect the VGA connector.

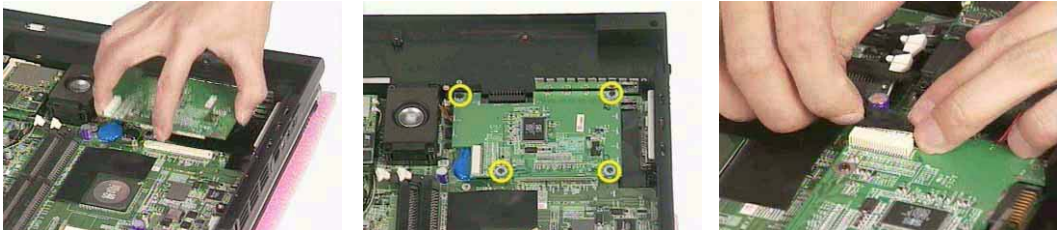

### Insert the memory

1. Insert the memory.

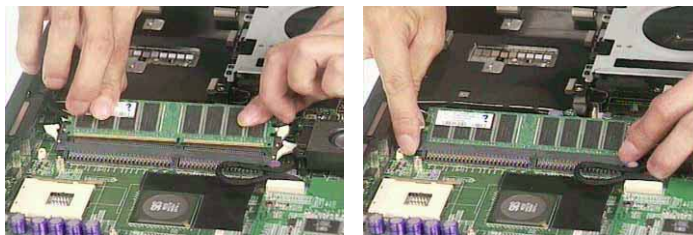

## Place the CPU back

1. Place the CPU back.

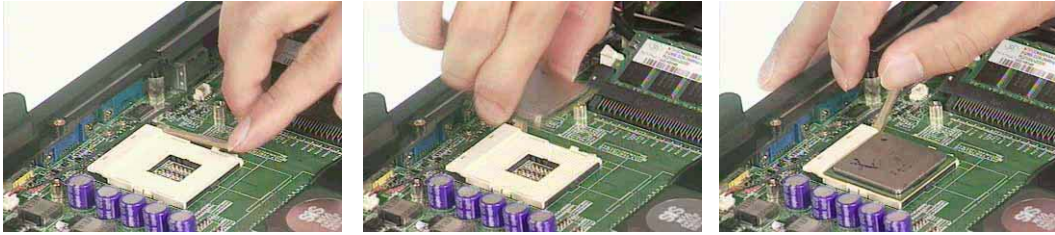

## Place the thermal module back to position

1. Place the thermal module back to position.
2. Secure the thermal module.
3. Reconnect the thermal fan connector.

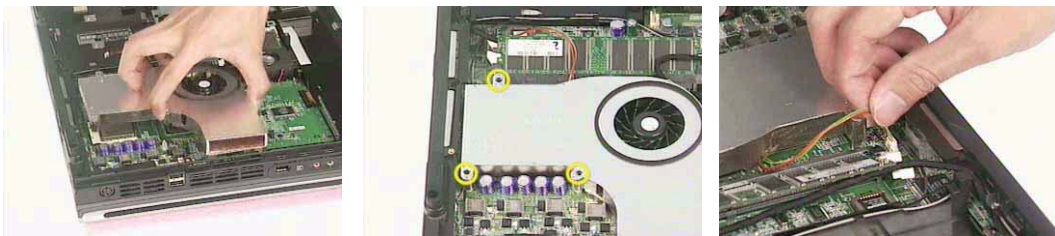

## Place the floppy back to position

1. Place the floppy back to position.
2. Secure the floppy.

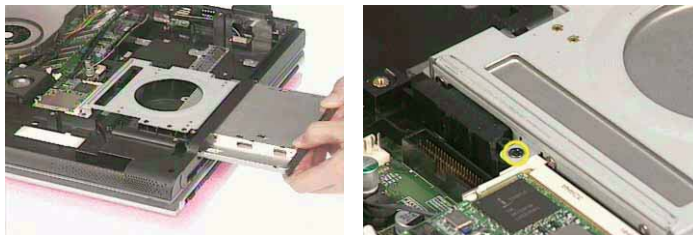

## Reconnect the HDD power and coaxial cable.

1. Reconnect the HDD power and coaxial cable.
2. And place the HDD back to position.
3. Secure the HDD module.



---

## Place the battery or dummy battery back to position.

1. Place the battery or dummy battery back to position.
2. Secure the battery module.

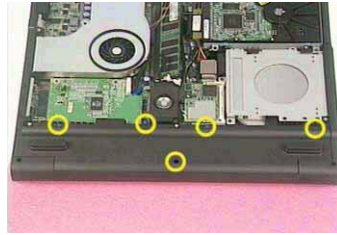

## Place the bottom shield back to position.

1. Place the bottom shield back to position.
2. Secure the bottom shield.



3. This completes the re-assembly procedures of Aspire 1700.



## FDD Module

1. Reattach the FDD bracket.



2. Secure the screw.
3. Reconnect the ribbon cable.

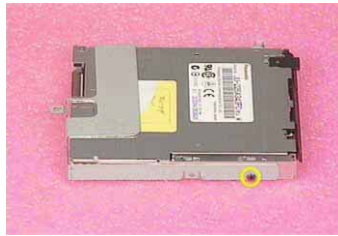

## HDD Module

1. Reattach the HDD bracket.
2. Secure the HDD with screws.



3. Reconnect the power cable and the coaxial cable.

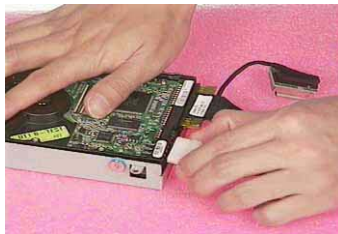

---

## Combo Module

1. Reattach the bracket.
2. Secure the combo with three screws.





## Troubleshooting

Use the following procedure as a guide for computer problems.

**NOTE:** The diagnostic tests are intended to test this model. Non-Acer products, prototype cards, or modified options can give false errors and invalid system responses.

1. Duplicate symptom and obtain the failing symptoms in as much detail as possible.
2. Distinguish symptom. Verify the symptoms by attempting to re-create the failure by running the diagnostic test or by repeating the same operation.
3. Disassemble and assemble the unit without any power sources.
4. If any problem occurs, you can perform visual inspection before you follow this chapter's instructions. You can check the following:
  - power cords are properly connected and secured;
  - there are no obvious shorts or opens;
  - there are no obviously burned or heated components;
  - all components appear normal.
5. Use the following table with the verified symptom to determine which page to go to.

Symptoms (Verified)	Go To
Power failure. (The power indicator does not go on or stay on.)	"Power System Check" on page 9.
POST does not complete. No beep or error codes are indicated.	"Power-On Self-Test (POST) Error Message" on page 11 "Undetermined Problems" on page 19
POST detects an error and displayed messages on screen.	"Error Message List" on page 12
The diagnostic test detected an error and displayed a FRU code.	"System Diagnostic Diskette" on page 43
Other symptoms (i.e. LCD display problems or others).	"Power-On Self-Test (POST) Error Message" on page 11
Symptoms cannot be re-created (intermittent problems).	Use the customer-reported symptoms and go to "Power-On Self-Test (POST) Error Message" on page 11 "Intermittent Problems" on page 18 "Undetermined Problems" on page 19

---

# System Check Procedures

## External Diskette Drive Check

Do the following to isolate the problem to a controller, driver, or diskette. A write-enabled, diagnostic diskette is required.

**NOTE:** Make sure that the diskette does not have more than one label attached to it. Multiple labels can cause damage to the drive or cause the drive to fail.

Do the following to select the test device. See “System Diagnostic Diskette” on page 43 for details.

1. Boot from the diagnostics diskette and start the diagnostics program (see “System Diagnostic Diskette” on page 43).
2. See if FDD Test is passed as the program runs to FDD Test.
3. Follow the instructions in the message window.

If an error occurs with the internal diskette drive, reconnect the diskette connector on the system board.

If the error still remains:

1. Reconnect the external diskette drive/DVD-ROM module.
2. Replace the external diskette drive/CD-ROM module.
3. Replace the main board.

## External CD-ROM Drive Check

Do the following to isolate the problem to a controller, drive, or CD-ROM. Make sure that the CD-ROM does not have any label attached to it. The label can cause damage to the drive or can cause the drive to fail.

Do the following to select the test device:

1. Boot from the diagnostics diskette and start the diagnostics program (refer to “System Diagnostic Diskette” on page 43).
2. See if CD-ROM Test is passed when the program runs to CD-ROM Test.
3. Follow the instructions in the message window.

If an error occurs, reconnect the connector on the System board. If the error still remains:

1. Reconnect the external diskette drive/CD-ROM module.
2. Replace the external diskette drive/CD-ROM module.
3. Replace the main board.

## Keyboard or Auxiliary Input Device Check

Remove the external keyboard if the internal keyboard is to be tested.

If the internal keyboard does not work or an unexpected character appears, make sure that the flexible cable extending from the keyboard is correctly seated in the connector on the system board.

If the keyboard cable connection is correct, run the Keyboard Test. See “System Diagnostic Diskette” on page 43 for details.

If the tests detect a keyboard problem, do the following one at a time to correct the problem. Do not replace a non-defective FRU:

1. Reconnect the keyboard cables.
2. Replace the keyboard.
3. Replace the main board.

The following auxiliary input devices are supported by this computer:

- Numeric keypad



- 
- External keyboard

If any of these devices do not work, reconnect the cable connector and repeat the failing operation.

## Memory check

Memory errors might stop system operations, show error messages on the screen, or hang the system.

1. Boot from the diagnostics diskette and start the doagmpstotics program (please refer to main board).
2. Go to the diagnostic memory in the test items.
3. Press F2 in the test items.
4. Follow the instructions in the message window.

**NOTE:** Make sure that the DIMM is fully installed into the connector. A loose connection can cause an error.

## Power System Check

To verify the symptom of the problem, power on the computer using each of the following power sources:

1. Remove the battery pack.
2. Connect the power adapter and check that power is supplied.
3. Disconnect the power adapter and install the charged battery pack; then check that power is supplied by the battery pack.

If you suspect a power problem, see the appropriate power supply check in the following list:

- "Check the Battery Pack" on page 10

---

## Check the Battery Pack

To check the battery pack, do the following:

From Software:

1. Check out the Power Management in control Panel
2. In Power Meter, confirm that if the parameters shown in the screen for Current Power Source and Total Battery Power Remaining are correct.
3. Repeat the steps 1 and 2, for both battery and adapter.
4. This helps you identify first the problem is on recharging or discharging.

From Hardware:

1. Power off the computer.
2. Remove the battery pack and measure the voltage between battery terminals 1(+) and 6(ground). See the following figure
3. If the voltage is still less than 7.5 Vdc after recharging, replace the battery.

To check the battery charge operation, use a discharged battery pack or a battery pack that has less than 50% of the total power remaining when installed in the computer.

If the battery status indicator does not light up, remove the battery pack and let it return to room temperature. Re-install the battery pack.

If the charge indicator still does not light up, replace the battery pack. If the charge indicator still does not light up, replace the DC/DC charger board.

## Touchpad check

If the touchpad doesn't work, do the following actions one at a time to correct the problem. Do not replace a non-defective FRU:

1. After rebooting, run Tracking Pad PS2 Mode Driver. For example, run Syn touch driver.
2. Run utility with the PS/2 mouse function and check if the mouse is working.
3. If the the PS/2 mouse does not work, then check if the main board to switch board FPC is connected O.K.
4. If the main board to switch board FPC is connected well, then check if the FCC on touch pad PCB connects properly.
5. If the FFC on touch pad PCB connects properly, then check if LS851 JP1 Pin6=5V are pulese. If yes, then replace switch board. If no, then go to next step.
6. Replace touch pad PCB.
7. If the touch pad still does not work, then replace FPC on Track Pad PCB.

After you use the touchpad, the pointer drifts on the screen for a short time. This self-acting pointer movement can occur when a slight, steady pressure is applied to the touchpad pointer. This symptom is not a hardware problem. No service actions are necessary if the pointer movement stops in a short period of time.

---

## Power-On Self-Test (POST) Error Message

The POST error message index lists the error message and their possible causes. The most likely cause is listed first.

**NOTE:** Perform the FRU replacement or actions in the sequence shown in FRU/Action column, if the FRU replacement does not solve the problem, put the original part back in the computer. Do not replace a non-defective FRU.

This index can also help you determine the next possible FRU to be replaced when servicing a computer.

If the symptom is not listed, see “Undetermined Problems” on page 19.

The following lists the error messages that the BIOS displays on the screen and the error symptoms classified by function.

**NOTE:** Most of the error messages occur during POST. Some of them display information about a hardware device, e.g., the amount of memory installed. Others may indicate a problem with a device, such as the way it has been configured.

**NOTE:** If the system fails after you make changes in the BIOS Setup Utility menus, reset the computer, enter Setup and install Setup defaults or correct the error.

---

## Index of Error Messages

### Error Message List

Error Messages	FRU/Action in Sequence
Struck Key	See “Keyboard or Auxiliary Input Device Check” on page 8
System CMOS checksum bad - Default configuration used	RTC battery Run BIOS Setup Utility to reconfigure system, then reboot system.
Real time clock error	RTC battery Run BIOS Setup Utility to reconfigure system time, then reboot system. Main board
Previous boot incomplete - Default configuration used	“Load Default Settings” in BIOS Setup Utility. RTC batter Main board.
Invalid System Configuration Data	“Load Default Settings” in BIOS Setup Utility. Main board.
Operating system not found	Enter Setup and see if fixed disk and drive A are properly identified. Dikette drive Hard disk drive Main board.

## Error Message List

No beep Error Messages	FRU/Action in Sequence
Power-on indicator turns off and LCD is blank.	Power source (battery pack and power adapter.) See "Power System Check" on page 9 Ensure every connector is connected tightly and correctly. Reconnect the DIMM. Main board.
Power-on indicator turns on and LCD is blank.	Power source (battery pack and power adapter.) See "Power System Check" on page 9 Reconnect the LCD connector Hard disk drive LCD cable LCD inverter LCD Main board
Power-on indicator turns on and LCD is blank. But you can see POST on an external CRT.	Reconnect the LCD connectors. LCD cable LCD inverter LCD Main board
Power-on indicator turns on and a blinking cursor shown on LCD during POST.	Ensure every connector is connected tightly and correctly. Main board

# Index of Symptom-to-FRU Error Message

## LCD-Related Symptoms

Symptom / Error	Action in Sequence
LCD backlight doesn't work	First, plug a monitor to CRT port. Next, enter BIOS utility to running "Load Default Settings" then reboot the system. Reconnect the LCD connectors. Keyboard (if the brightness function key doesn't work). LCD cable LCD inverter LCD Main board
LCD is too dark LCD brightness cannot be adjusted	Enter BIOS Utility to execute "Load Setup Default Settings", then reboot system. Reconnect the LCD connectors. Keyboard (if the brightness function key doesn't work). LCD cable LCD inverter LCD Main board
Unreadable LCD screen Missing pels in characters Abnormal screen Wrong color displayed LCD has extra horizontal or vertical lines displayed.	Reconnect the LCD cable LCD cable LCD Main board

## Indicator-Related Symptoms

Symptom / Error	Action in Sequence
Indicator incorrectly remains off or on, but system runs correctly	Main board
HDD/CD-ROM active indicators cannot work	HDD/CD-ROM drive Device driver Main board

## Power-Related Symptoms

Symptom / Error	Action in Sequence
Power shuts down during operation	Power source (battery pack and power adapter). See "Power System Check" on page 9. Battery pack AC adapter See if the thermal module is overheat (Heat sink or fan). Main board
The system cannot power-on.	Power source (battery pack and power adapter). See "Power System Check" on page 9. Battery pack Power adapter CPU Main board
The system cannot power-off.	In Windows XP operating system, hold and press the power switch for more than 4 seconds. If the system can power off, then the main board is OK. Verify OS in the HDD. Main board

### Power-Related Symptoms

Symptom / Error	Action in Sequence
Battery can't be charged or discharged	See "Check the Battery Pack" on page 10. Battery pack Main board
System hang during POST	ODD/HDD/FDD/RAM module Main board

### PCMCIA-Related Symptoms

Symptom / Error	Action in Sequence
System cannot detect the PC Card (PCMCIA)	PCMCIA slot assembly Main board
PCMCIA slot pin is damaged.	PCMCIA slot assembly
PC Card cannot be inserted or ejected	Check if the PCMCIA slot is blocked Main board

### Memory-Related Symptoms

Symptom / Error	Action in Sequence
Memory count (size) appears different from actual size.	Enter BIOS Setup Utility to execute "Load Default Settings" then reboot system. RAM module Main board Check BIOS revision
System can power on, but you hear two long beeps: "B--, B--" and the LCD is blank.	Reinsert DIMM DIMM Main board

### Speaker-Related Symptoms

Symptom / Error	Action in Sequence
In Windows, multimedia programs, no sound comes from the computer.	OS volume control Audio driver Speaker Main board
Internal speakers make noise or emit no sound.	Speaker Main board
Microphone cannot work	Audio driver Volume control in Windows XP Main board

### Power Management-Related Symptoms

Symptom / Error	Action in Sequence
The system will not enter hibernation mode	Power option in Windows XP Hard disk drive Main board
The system doesn't enter standby mode after closing the lid of the portable computer.	Driver of Power Option Properties Lid close switch in upper case Main board

## Power Management-Related Symptoms

Symptom / Error	Action in Sequence
The system doesn't resume from hibernation/standby mode.	Connect AC adapter then check if the system resumes from Standby/Hibernation mode. Check if the battery is low. Hard disk drive Main board
The system doesn't resume from standby mode after opening the lid of the portable computer.	LCD cover switch Main board
Battery fuel gauge in Windows doesn't go higher than 90%.	Refresh battery (continue use battery until power off, then charge battery). Battery pack Main board
System hangs intermittently.	Reconnect hard disk/CD-ROM drives. Main board

## Peripheral-Related Symptoms

Symptom / Error	Action in Sequence
System configuration does not match the installed devices.	Enter BIOS Setup Utility to execute "Load Setup defaults", then reboot system. Reconnect hard disk/CD-ROM drives/FDD or other peripherals. Main board
External display does not work correctly.	Press Fn+F5, LCD/CRT/Both display switching Keyboard Main board
USB does not work correctly	See "System Diagnostic Diskette" on page 43 Main board
Print problems.	Enter BIOS Setup Utility to execute "Load Default Settings" then reboot the system. Run printer self-test. Printer driver Printer cable Printer Main board
Parallel port device problems	Enter BIOS Setup Utility to execute "Load Default Settings" then reboot the system. Device driver Device cable Device Main board

## Keyboard/Touchpad-Related Symptoms

Symptom / Error	Action in Sequence
Keyboard (one or more keys) does not work.	Reconnect the keyboard cable. Keyboard Main board
Touchpad does not work.	Reconnect touchpad cable. Touchpad board Main board



---

### Modem/LAN-Related Symptoms

Symptom / Error	Action in Sequence
Internal modem does not work correctly.	See "System Diagnostic Diskette" on page 43. Phone cable Driver Reconnect the Internal modem cable to the main board tightly. Main board
Internal LAN does not work correctly	Lan cable Driver Main board

**NOTE:** If you cannot find a symptom or an error in this list and the problem remains, see "Undetermined Problems" on page 19.

---

## Intermittent Problems

Intermittent system hang problems can be caused by a variety of reasons that have nothing to do with a hardware defect, such as: cosmic radiation, electrostatic discharge, or software errors. FRU replacement should be considered only when a recurring problem exists.

When analyzing an intermittent problem, do the following:

1. Run the diagnostic test for the system board in loop mode at least 10 times.
2. If no error is detected, do not replace any FRU.
3. If any error is detected, replace the FRU. Rerun the test to verify that there are no more errors.

---

## Undetermined Problems

The diagnostic problems does not identify which adapter or device failed, which installed devices are incorrect, whether a short circuit is suspected, or whether the system is inoperative.

Follow these procedures to isolate the failing FRU (do not isolate non-defective FRU).

**NOTE:** Verify that all attached devices are supported by the computer.

**NOTE:** Verify that the power supply being used at the time of the failure is operating correctly. (See "Power System Check" on page 9):

1. Power-off the computer.
2. Visually check them for damage. If any problems are found, replace the FRU.
3. Remove or disconnect all of the following devices:
  - Non-Acer devices
  - Printer, mouse, and other external devices
  - Battery pack
  - Hard disk drive
  - DIMM
  - PC Cards
4. Power-on the computer.
5. Determine if the problem has changed.
6. If the problem does not recur, reconnect the removed devices one at a time until you find the failing FRU.
7. If the problem remains, replace the following FRU one at a time. Do not replace a non-defective FRU:
  - System board
  - LCD assembly

*justmanuals.com*



# Jumper and Connector Locations

## Aspire 1700 Jumpers and Connectors

Top view

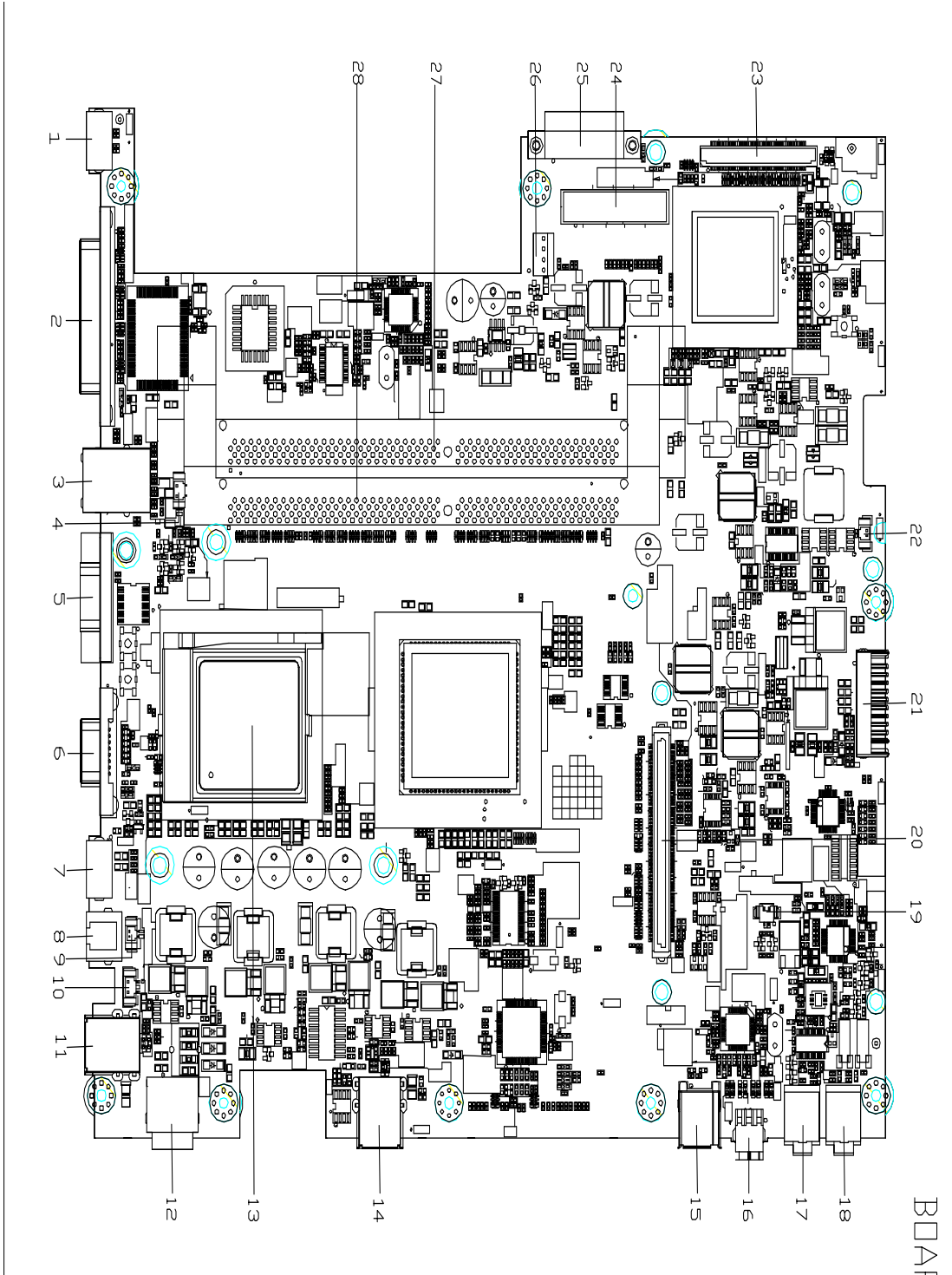

---

## Connector Description

Connector No.	Description
1	PS2 port
2	Parallel port
3	LAN connector
4	CPU fan connector
5	COM1 port
6	VGA port
7	S-video port
8	Modem connector
9	MDC connector
10	System fan connector
11	USB port
12	DC in connector
13	CPU socket
14	USB port
15	1394 connector
16	Mini 1394 connector
17	MIC connector
18	Line out connector
19	Woofers connector
20	VGA board connector
21	Battery connector
22	RTC battery connector
23	PCI board connector
24	HDD connector
25	CD/DVD-ROM module connector
26	HDD power connector
27	DDR RAM socket-1
28	DDR RAM socket-2

# Bottom View

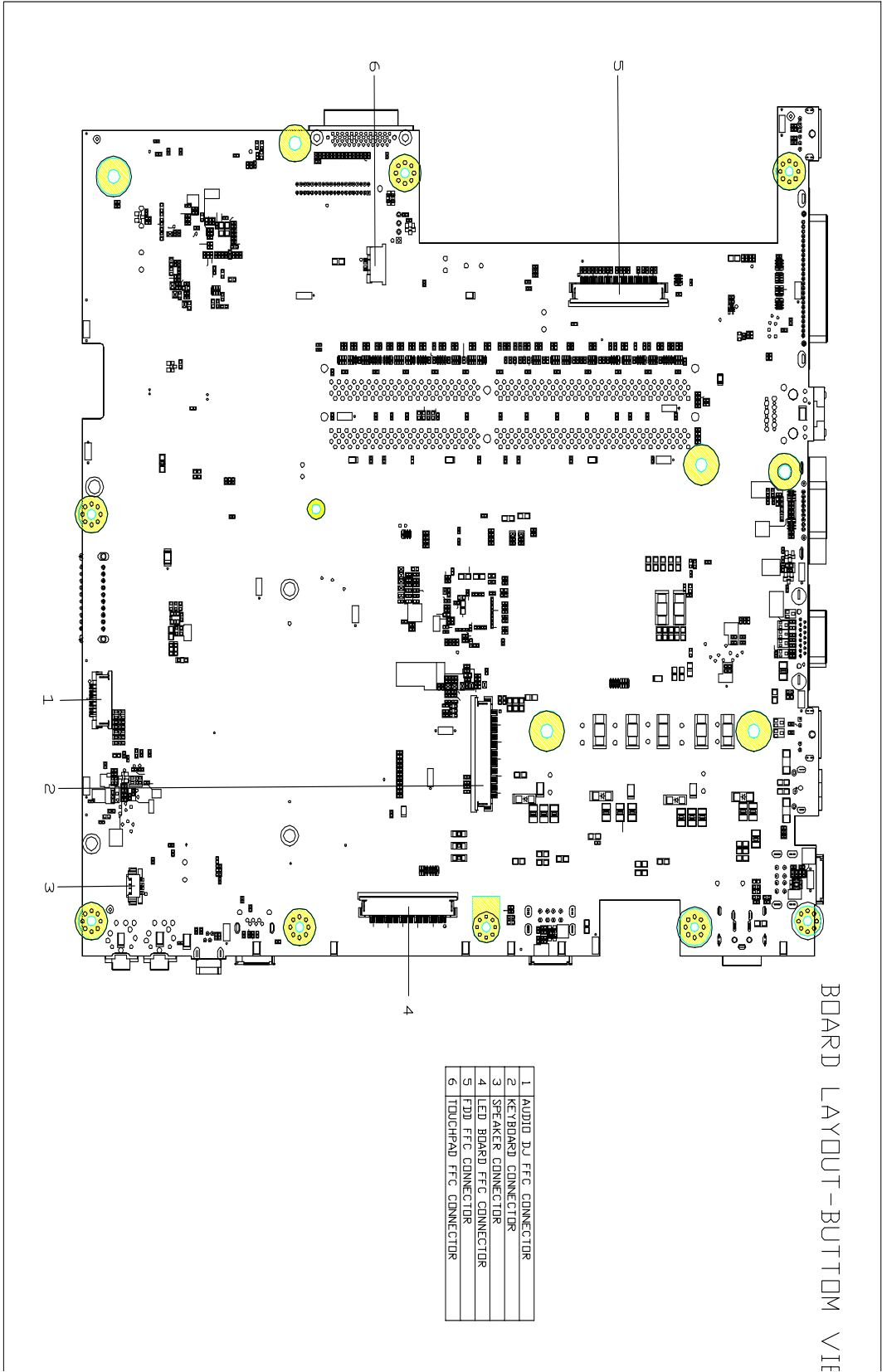

---

## Connector Description

Connector No.	Description
1	Audio DJ FFC connector
2	Keyboard connector
3	Speaker connector
4	LED board FFC connector
5	FDD FFC connector
6	Touchpad FFC connector



# FRU List

## Exploded Diagram

### The System

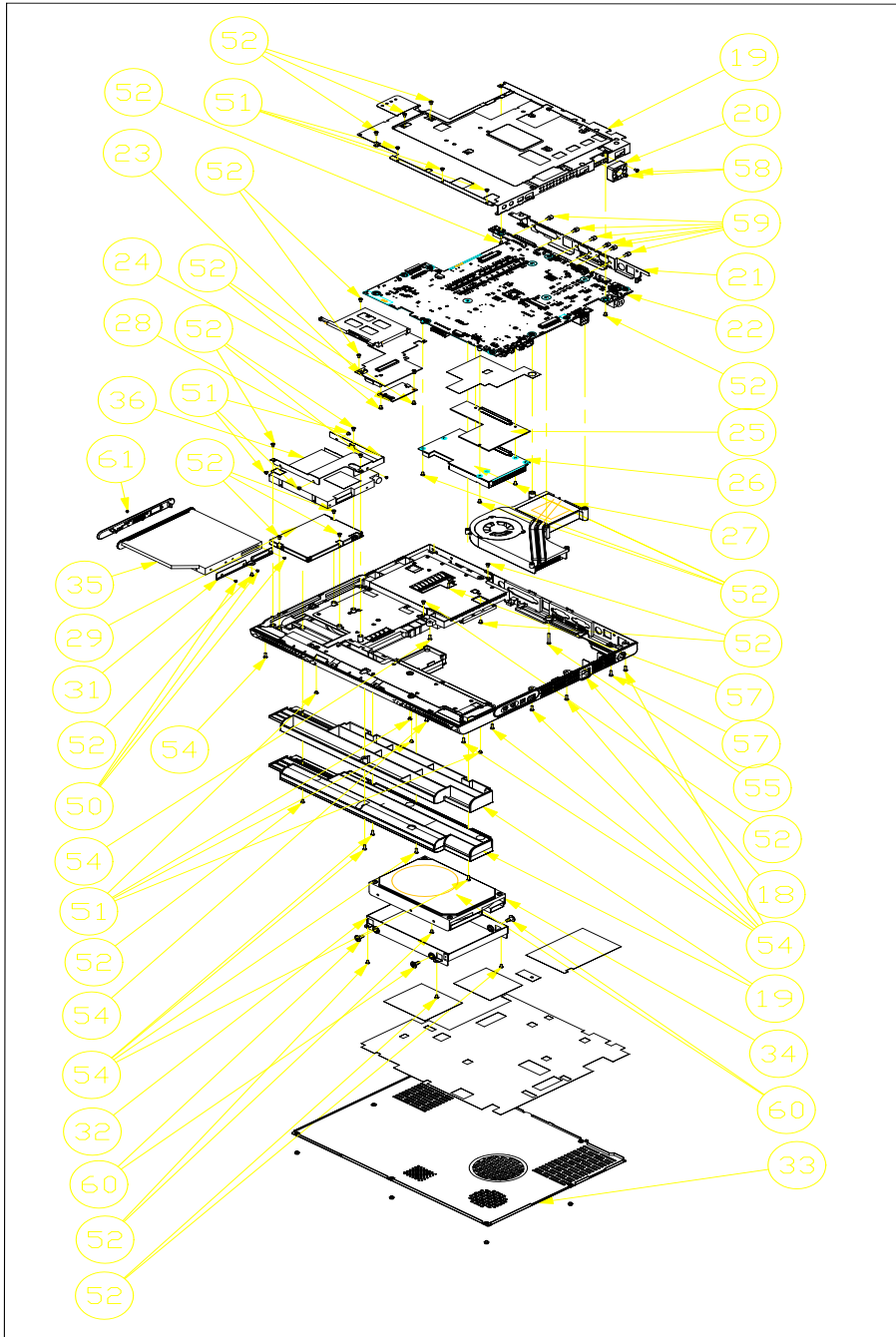

## LCD 17" ASSY

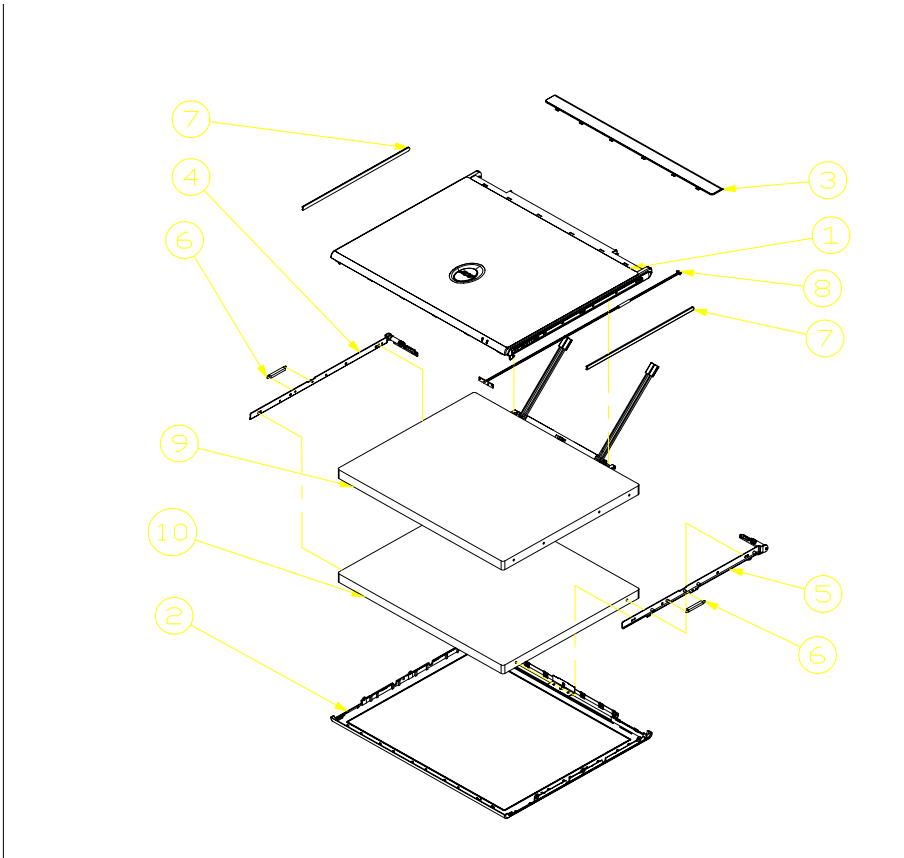

## FDD ASSY

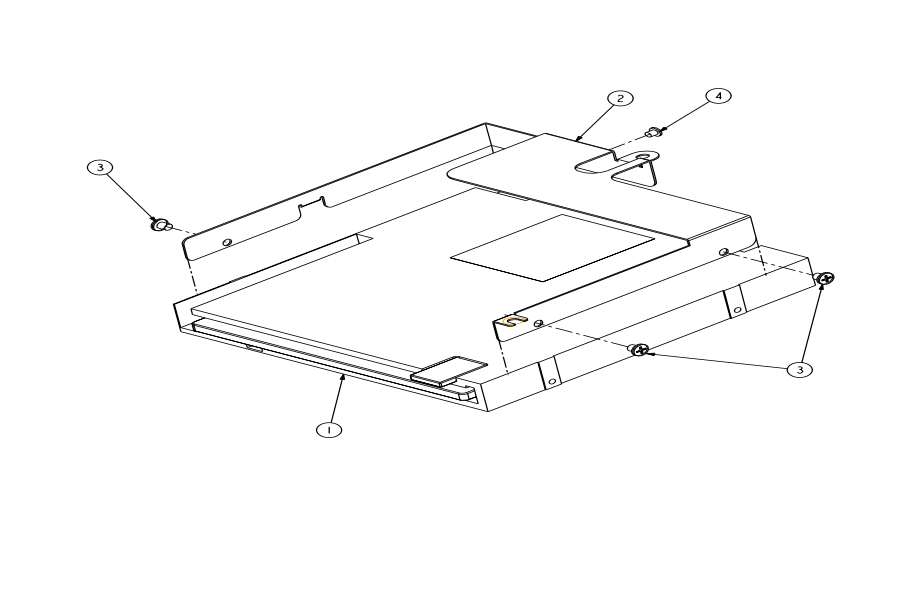

# HDD ASSY

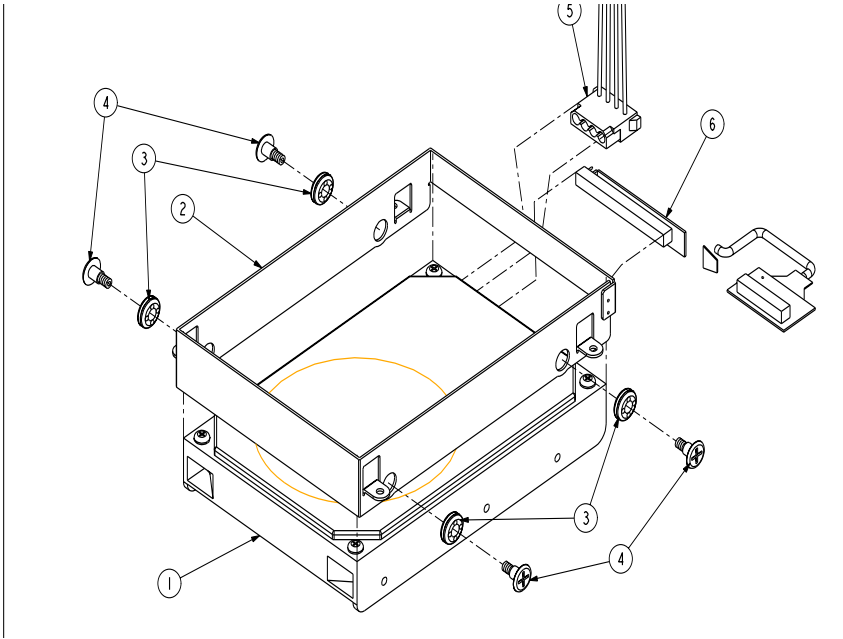

# ODD ASSY

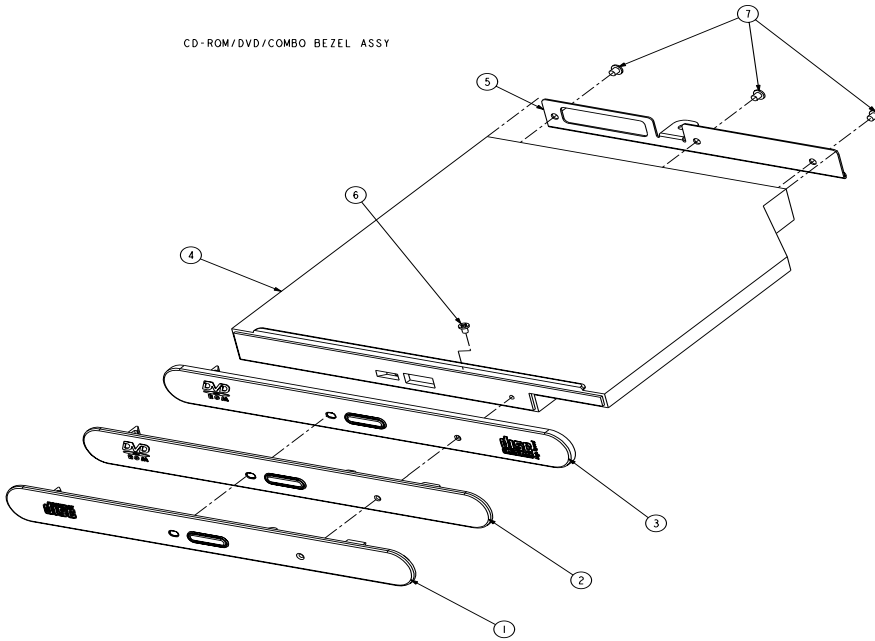



# FRU List









Picture	No.	Partname And Description	Part Number
CPU/Processor			
		INTEL PENTIUM 4 NORTHWOOD 2.53GHZ/512K/533FSB INTEL PENTIUM 4 NORTHWOOD 3.06GHZ/512K/533FSB INTEL CELERON 1.8GHZ/128K/400FSB, SL68D INTEL CELERON 2.0GHZ/128K/400FSB	KC.DPM01.253 01.NORTH.306 01.ICLON.1GK KC.DCM01.20A
Memory			
		SDRAM 256MB DDR266 INFINEON HYS64D32000GU-7-B SDRAM 512MB DDR266 INFINEON HYS64D64020GU-7-B SDRAM 256MB DDR266 NANYA NT256D64S88AAG-7K ( SDRAM 512MB DDR266 NANYA NT512D64S8HAAG-7K	KN.25602.002 KN.51202.001 KN.25603.002 KN.51203.001
LCD			
		LCD MODULE 17" TFT SXGA QDI QD17EL07	6M.A08V7.003
		LCD 17" TFT SXGA QDI QD17EL07	LK.17009.001
		INVERTER BOARD	55.A08V7.006
		WIRE LED CABLE 17"	50.A08V7.008
		LCD CABLE SET	50.A08V7.009
		COVER SWITCH CABLE (LID SWITCH CABLE)	50.A08V7.010
		LCD HINGE R+L 17"	6K.A08V7.001
		LCD PANEL W/ WIRELESS LAN LED CABLE, LATCH, BUTTOM, SPRING, LOGO 17"	60.A08V7.004
		LCD BUTTOM	42.A08V7.005

Picture	No.	Partname And Description	Part Number
		LCD BEZEL W/ ACER LOGO 17"	60.A08V7.006
		LCD LATCH 17"	47.A08V7.001
		LCD SPRING 17"	47.A08V7.002
		LCD ACER LOGO	47.A08V7.003
		LCD DECORATION BAR 17"	47.A08V7.004
FDD/Floppy Disk Drive			
		FDD MODULE 1.44MB SLIM PANASONIC JU226A273FC	6M.A08V7.002
		FDD 1.44MB SLIM PANASONIC/JU226A273FC	KF.22602.001
		FDD FFC CABLE	50.A08V7.005
		FDD BRACKET	33.A08V7.005
HDD/ Hard Disk Drive			
		HDD 3.5" 80G U7 5400RPM SEAGATE ST380022A HDD 3.5" 80G U9 5400RPM SEAGATE ST380012A HDD 3.5" 120G(L) 7200RPM MAXTOR CALYPSO 6Y120L0 HDD 3.5" 120G 7200RPM SEAGATE CUDA V	KH.38001.003 KH.08001.002 KH.12003.002 KH.31201.001
		HDD CABLE, 40PIN	50.A08V7.006
		HDD POWER CABLE, 4PIN, IDE	50.A08V7.007
		HDD CASE	33.A08V7.006
		HDD SCREW	86.A08V7.019
Optical Drive/Combo Drive			

Picture	No.	Partname And Description	Part Number
		DVD-RW COMBO MODULE 24X QSI SBW242	6M.A08V7.001
		DVD/CD-RW COMBO 24X QSI SBW242	KO.24X07.001
		ODD BRACKET	33.A08V7.004
		DVD-RW COMBO DRIVE BEZEL	42.A08V7.004
Cables			
	NS	POWER CORD US POWER CORD CONTINENTAL POWER CORD UK POWER CORD ITALIAN POWER CORD DANISH POWER CORD SWISS	50.A08V7.011 50.A08V7.012 50.A08V7.013 50.A08V7.014 50.A08V7.015 50.A08V7.016
		LAUNCH BOARD FFC CABLE (LAUNCH BOARD TO MB)	50.A08V7.001
		FFC CABLE (TOUCHPAD TO TOUCH SWITCH)	50.A08V7.002
		FFC CABLE (TOUCH SWITCH TO M/B)	50.A08V7.003
		AUDIO DJ FFC CABLE (AUDIO BOARD TO M/B)	50.A08V7.004
Boards			

Picture	No.	Partname And Description	Part Number
		PCI WIRELESS LAN CARD AMBIT 802.11B	55.A08V7.007
		MDC MD BOARD AMBIT AGERE MODEM	55.A08V7.008
		NVIDIA NV-18M 64MB AGP CARD	VG.44808.001
		LAUNCH BOARD	55.A08V7.001
		AUDIO DJ BOARD	55.A08V7.002
		TOUCH SWITCH BOARD	55.A08V7.003
		TOUCHPAD BOARD	55.A08V7.004
		PCMCIA DAUGHTER BOARD W/ CARDBUS SLOT	55.A08V7.005
	THE SYSTEM	M/B W/ BATTERY	MB.A0806.001
PCMCIA SLOT/PC CARD SLOT			
		PCMCIA SLOT (CARDBUS SLOT)	22.A08V7.001
Battery			
	NS	M/B Battery	23.A08V7.001
Adapter			
	NS	ADAPTER 150W PFC 3PINS DELTA ADP-150W	PY.15009.001
Keyboard			



Picture	No.	Partname And Description	Part Number
		KEYBOARD SUNREX GERMAN	KB.A0809.003
		KEYBOARD SUNREX UK	KB.A0809.002
		KEYBOARD SUNREX ITALIAN	KB.A0809.004
		KEYBOARD SUNREX FRENCH	KB.A0809.005
		KEYBOARD SUNREX SWISS/G	KB.A0809.006
		KEYBOARD SUNREX US INTERNATIONAL	KB.A0809.001
		KEYBOARD SUNREX BELGIUM	KB.A0809.010
		KEYBOARD SUNREX SPANISH	KB.A0809.007
		KEYBOARD SUNREX PORTUGUESE	KB.A0809.008
		KEYBOARD SUNREX CZECH	KB.A0809.012
		KEYBOARD SUNREX HUNGAIAN	KB.A0809.013
		KEYBOARD SUNREX SWEDEN	KB.A0809.011
		KEYBOARD SUNREX NORWAY	KB.A0809.014
		KEYBOARD SUNREX DANISH	KB.A0809.015
	KEYBOARD SUNREX ARABIC	KB.A0809.009	
	KEYBOARD SUNREX TURKISH	KB.A0809.016	
Case/Cover/Bracket Assembly			
		BASE COVER	60.A08V7.001
		BASE	60.A08V7.002
	NS	BATTERY DOMMY COVER W/ FOOT	42.A08V7.001
		INVERTER COVER	42.A08V7.002
		UPPER CASE	60.A08V7.003
		HINGE COVER	42.A08V7.003
		I/O BRACKET	33.A08V7.001
		TOUCH PAD BRACKET	33.A08V7.002

Picture	No.	Partname And Description	Part Number
		M/B PLATE	33.A08V7.003
Others			
		SPEAKER R+L VECO 28KC04-1	23.A08V7.001
		SPEAKER FOIL	47.A08V7.005
		SUB-WOOFER 2PIN VECO 25KP04	23.A08V7.002
		M/B SYSTEM FAN	23.A08V7.002
		FAN SINK W/ SCREWS*4PCS	23.A08V7.003
Screws			
		SCREW MM30060IL67	86.A08V7.001
		SCREW MM25025ICI0	86.A08V7.002
		SCREW MM25040IL60	86.A08V7.003
		SCREW MM25060IL69	86.A08V7.004
		SCREW MM20030ICI3	86.A08V7.005
		SCREW MM20080ICI6	86.A08V7.006
		SCREW MM20100ICI3	86.A08V7.007
		SCREW MS17025B202	86.A08V7.008
		SCREW MBEA1001012	86.A08V7.009
		SCREW MF30060PBJ5	86.A08V7.010
		SCREW MM25070ICI5	86.A08V7.011
		SCREW MS25060ILR1	86.A08V7.012
		SCREW MS25060P527	86.A08V7.013
		SCREW MM25040ICI1	86.A08V7.014
		SCREW MS25025IBX8	86.A08V7.015
		SCREW MS25180I100	86.A08V7.016
		SCREW MS25100B371	86.A08V7.017
		SCREW MS0601BILQ1	86.A08V7.018

## Model Definition and Configuration

---

### Aspire 1700 Series

Model Number	CPU	LCD	Memory	HDD (GB)	ODD	Card Reader	Wireless LAN
1702SC	Pentium 4 2.53GHz	17.0" SXGA	512M	80G	24x CDRW+DVD	N/A	N/A
1702SCi	Pentium 4 2.53GHz	17.0" SXGA	512M	80G	24x CDRW+DVD	N/A	11b
1703SC	Pentium 4 2.66GHz	17.0" SXGA	512M	80G	24x CDRW+DVD	N/A	N/A
1703SCi	Pentium 4 2.66GHz	17.0" SXGA	512M	80G	24x CDRW+DVD	N/A	11b
1705SCi	Pentium 4 3.06GHz	17.0" SXGA	512M	120G	24x CDRW+DVD	N/A	11b

---

## Main Features

- ❑ Mobile Intel® Pentium® 4 Northwood 1.8~3.06 GHz/Celeron processor L2 cache 512k (Northwood), 128K (Celeron)
- ❑ SiS M650 with SiS 962, support 400/533MHz Bus, HTT support.
- ❑ 15" Desktop XGA and 17" Desktop SXGA.
- ❑ Optional 6-in-1 Multimedia memory card module
- ❑ Optical drive bay for optional CD-ROM, DVD-ROM, DVD/CD-RW combo
- ❑ Two stereo speakers + One sub-woofer
- ❑ Modem: Software Modem V9.0/V9.2 56Kbps
- ❑ 10/100 LAN; Optional Mini-PCI 802.11b/802.11a+b/bluetooth; One switch for on/off of wireless
- ❑ Keyboard and touchpad with 4 way scroll buttons; 4 universal serial bus (USB) ports.



## Test Compatible Components

---

This computer's compatibility is tested and verified by Acer's internal testing department. All of its system functions are tested under Windows® XP Home, Windows® XP Pro and Windows® 2000 environment.

Refer to the following lists for components, adapter cards, and peripherals which have passed these tests. Regarding configuration, combination and test procedures, please refer to the TravelMate 650 series Compatibility Test Report released by the Acer Mobile System Testing Department.

# Microsoft® Windows® XP Environment Test

Item	Specifications
Display	Philips 109P 10 Dell Trinitron 21° ViewSonic GS773 ViewSonic GS790 ViewSonic PF775
Parallel Port	Printer: HP Laser Jet 5M HP Desk Jet 930C HP Desk Jet 840C IOMega ZIP (LPT Port) Cable: LL5 cable
1394 Port	1394 30GB HDD 1394 CCD(Stealth Fire) 1394(stealthFire tm) 1394 HUB: Aten 1394 HUB 1394 DV (Sony DCR-PC100)
Projector	Acer 7755c
USB 2.0	USB (HUB FH-600)aten firewire HUB 5port USB HDD: Easy BOX USB (yamaha)CRW-70 USB DVD/CD-RW(pioneer)DVR-104 Adaptec USB 2.0 PCMCIA card
GB LAN HUB	3 COM GB LAN Hub
PS/2 Port	Keyboard: Microsoft Natural K/B K/B(MODE:5121) KeyPad: PC concepts keypad KB-5640 Mouse: Microsoft IntelliMouse Explorer Microsoft PS/2 Mouse COMPAQ Mouse
COM Port	Microsoft Serial Mouse 2.1

Item	Specifications
PC Card	<p><b>Modem Card:</b>  Xircom CreditCard Modem 56 (CM-56)  Xircom CreditCard Modem 56 (CM-56G)</p> <p><b>LAN Card:</b>  D-Link Fast Ethernet DFE-650  D-Link CardBus DFE-660  3COM 10/100 16Bit LAN Card (3CCFE574BT)  3COM 10/100 CardBus LAN Card (3CCFE575BT)  3COM 10M CardBus LAN Card (3CCFE589eT)  Xircom CreditCard Ethernet 10/100 (CE3B-100BTX)  Xircom CardBus Ethernet II 10/100 (CBE2-100BTX)</p> <p><b>SCSI:</b>  Adaptec SlimSCSI APA-1460D Card  Adaptec SlimSCSI 1480A CardBus UltraSCSI Card</p> <p><b>LAN + Modem Card:</b>  3COM 10/100 LAN+56k Modem Card (3CCFEM556B)  Xircom CreditCard Ethernet + Modem 56k (CEM56-100)</p> <p><b>ATA Card:</b>  KingMax 40MB  Compact Flash 96MB</p> <p><b>1394 CardBus Card:</b>  <b>Compaq 1394 CardBus Card</b></p> <p><b>Wireless LAN Card:</b>  <b>Gemtek Wireless LAN Card</b></p> <p><b>BlueTooth Card:</b>  <b>3Com BlueTooth Card</b></p> <p><b>MMC Card:</b>  <b>Apacer 32MB</b></p> <p><b>MS Card:</b>  <b>Apacer 128MB</b></p> <p><b>SD Card:</b>  <b>Apacer 128MB</b></p> <p><b>CF Card:</b>  <b>Apacer 128MB</b></p>



Item	Specifications
USB Port	USB Mouse: Microsoft Optical USB Mouse Logitech Wheel Mouse Acer USB Mouse M012B0 USB Keyboard: Microsoft Internet Keyboard Pro Gateway Keyboard SK-9910U Gateway Keyboard SK-9926 USB Camera: Microtek EyeStar U2S PC Camera USC-1 Dlink DSC 350 USB CCD USB HDD: Argosy HDD USB Printer: HP DeskJet 930C HP DeskJet 840C USB FDD: MIC USB FDD YD-8U10 Teac USB FDD Y-E Data USB FDD Sharp USB FDD USB LAN: BUFFALO USB-10/100M ethernet LINKSYS USB LAN USB Zip: IOMEGA USB ZIP USB Scanner: HP ScanJet 5300c USB Speaker: Philips USB Speaker dss330 USB HUB: PCI USB Hub XeXtreme USB HUB USB Gamepad: Microsoft Sidewinder Gamepad Logitech WingMan FORMULA FORCE USB CCD: Intel USB CCD Veo USB CCD USB Modem: V.90 56Kbps Voice/Fax/Data Modem USB Card Reader: 6in1 USB To PS/2 Transfer Connector USB To Serial Transfer Connector
Audio Jack	JS-100 Jazz 3D Speaker AIWA HP-X121 Earphone SONY Earphone MDR-CD60 Microsoft Microphone
Microphone	Condenser MIC. Dynamic MIC.

*justmanuals.com*

---

Item	Specifications
Game	Harry Potter Star Wars Rogue Squadron starcraft Quake III
Access Point	Intel Access Point
Software	Microsoft Office 2K Microsoft Office XP Microsoft Project 2000 Lotus Notes 5.1 WinFax10.0 WinFax10.0 Adobe Acrobat 5.0 VC ++ 6.0 Microsoft FrontPage2002



## Online Support Information

---

This section describes online technical support services available to help you repair your Acer Systems.

If you are a distributor, dealer, ASP or TPM, please refer your technical queries to your local Acer branch office. Acer Branch Offices and Regional Business Units may access our website. However some information sources will require a user i.d. and password. These can be obtained directly from Acer CSD Taiwan.

Acer's Website offers you convenient and valuable support resources whenever you need them.

In the Technical Information section you can download information on all of Acer's Notebook, Desktop and Server models including:

- Service guides for all models
- User's manuals
- Training materials
- Bios updates
- Software utilities
- Spare parts lists
- TABs (Technical Announcement Bulletin)

For these purposes, we have included an Acrobat File to facilitate the problem-free downloading of our technical material.

Also contained on this website are:

- Detailed information on Acer's International Traveler's Warranty (ITW)
- Returned material authorization procedures
- An overview of all the support services we offer, accompanied by a list of telephone, fax and email contacts for all your technical queries.

We are always looking for ways to optimize and improve our services, so if you have any suggestions or comments, please do not hesitate to communicate these to us.



**A**

- ACPI 18
- Assignment Map 14
- Audio
  - controller 12
  - Audio Interface 12

**B**

- BIOS Setup Utility 19
- BIOS Utility 19
  - Basic System Settings 24
  - Navigating 20
  - Onboard Device Configuration 26
  - Startup Configuration 25
  - System Information 20
  - System Security 29

**C**

- Cache Memory 11
  - scheme 11
  - size 11
  - speed 11
  - type 11
  - voltage 11
- Chipsets 16
- Connectors 85
- controllers 16
  - audio 12
  - serial port 13
  - video 11

**D**

- Device Standby Mode 18
- Dimensions 17
- Disassembly
  - CD-ROM/DVD-ROM Module 36
  - Procedure Flowchart 33
- DRQ Assignment Map 16

**E**

- ECP 13
- Environmental Requirements 16

- EPP 13
- Error Symptom-to-Spare Part Index 75
- External CD-ROM Drive Check 72
- External Diskette Drive Check 72

**F**

- FDC 37C677 13
- Features 2, 101
  - connectivity 2
  - design 2
  - ergonomics 2
  - Multimedia 2
  - Performance 2
- front panel 3

**G**

- Global Standby Mode 18

**H**

- Humidity 16

**I**

- I/O Address Map 15
- IDE Interface 13
- Interface
  - audio 12
  - Floppy disk drive 13
  - IDE 13
  - Video 11
- Intermittent Problems 82
- IRQ Assignment Map 15

**J**

- Jumper and Connector Locations 85, 89
  - Top View 85, 89
- Jumpers 85, 89

**K**

- keyboard 9
  - cursor keys 9
- Keyboard or Auxiliary Input Device Check 72

---

## M

- Main board Layout 9
- Mechanical Specifications 17
- Memory
  - size 11
  - system 11
- Memory Address Map 14
- Memory Check 73
- Model Definition 100
- Modem 14
  - voice 14
- MPU-401 13

## N

- NS16C550 13

## O

- Online Support Information 109
- Overview 1

## P

- Parallel Port 13
- PCI INTx# 14
- ports
  - left panel 4
- Power Management 18
- Power System Check 73
  - Battery Pack 74

## R

- Rear Panel 3

## S

- Serial Port 13
- SiS 630 16
- socket
  - memory 11
- Suspend Mode 18
- System Specifications 1
  - design 2
  - Features 2, 101
- System Utilities 19

## T

- Temperature 16

- Test Compatible Components 103
- Touchpad Check 74
- Troubleshooting 71

## U

- UART 13
- Undetermined Problems 83
- Universal HCI 14
- USB Port 14
  - utility
  - BIOS 19

## V

- Vibration 16
- video
  - controller 11
- Video controller 11
- Video Memory 11
  - size 11

## W

- Weight 17
- Windows 2000 Environment Test 104